



METEOROLOGICAL INSTRUMENTS

INSTRUCTIONS

**WIND MONITOR - SE
MODEL 09101**





MODEL 09101 WIND MONITOR - SE



WIND SPEED SPECIFICATION SUMMARY

Range	0 to 100 m/s (224 mph)
Resolution:	0.1 unit
Accuracy:	±0.3 m/s (0.6 mph) or 1% of reading
Threshold:	1.0 m/s (2.2 mph)
Distance constant:	2.7 m (8.9 ft)
Transducer:	Rotating magnet and stationary coil.

WIND DIRECTION (AZIMUTH) SPECIFICATION SUMMARY

Range:	0-360 degrees
Accuracy:	± 2 degrees
Resolution:	1 degree
Threshold:	1.1 m/s (2.5 mph) @ 10° displacement
Delay distance:	1.3 m (4.3 ft)
Damping ratio:	0.3
Transducer:	Absolute encoder

GENERAL

Power requirement:	11-24 VDC, 20 mA
Dimensions:	Overall height 37 cm Overall length 55 cm Propeller 18 cm diameter Mounting 34 mm (1.34 in) diameter (standard 1 inch pipe)
Weight:	Sensor weight 1.0 kg (2.2 lb) Shipping weight 2.3 kg (5.0 lb)
Voltage Output:	WS: 0-5 VDC for 0-100 m/s WD: 0-5 VDC for 0-540°
Serial RS-485:	2 wire-half duplex, 1200-9600 Baud RMY, NCAR, NMEA, or RMYT protocols Polled or continuous
Operating Temperature:	-50 to 50°C (-58 to 122°F)

INTRODUCTION

The Wind Monitor-SE combines the performance and durability of the standard Wind Monitor with an optically encoded direction transducer and serial data output capability.

The wind speed sensor is a four blade helicoid propeller that turns a multipole magnet. Propeller rotation induces a variable frequency signal in a stationary coil. Slip rings and brushes are not used.

The wind direction sensor is a durable molded vane. An optical encoder measures vane angle, thereby eliminating the characteristic deadband and wear of potentiometer transducers. The encoder is an absolute type so direction output remains accurate even if power is interrupted.

Raw transducer signals are processed by onboard electronics. A variety of serial protocols or a conventional calibrated voltage output may be selected with simple internal jumpers.

The Wind Monitor-SE is designed for superior environmental resistance. Housing parts are UV stabilized thermoplastic. Fittings are stainless steel and anodized aluminum. Precision grade stainless steel ball bearings are used throughout. The instrument mounts on standard 1 inch pipe.

INITIAL CHECKOUT

Remove the sensor from its shipping carton. Remove the plastic nut from the propeller shaft and install the propeller with the teeth on the propeller hub engaging the slots on the shaft hub. Tighten plastic propeller nut **finger-tight only**. Do not overtighten.

The instrument is fully balanced, aligned, and calibrated before shipment. Some simple checks can be made to verify proper function. Both vane and propeller should rotate easily without friction. Check vane balance by holding sensor with vane surface horizontal. The vane should have no tendency to rotate. A slight imbalance will not degrade performance.

INITIAL SETUP

The 09101 has been calibrated at the factory and requires no additional adjustments. Operation is configured by onboard jumpers and software commands.

Unless otherwise specified, the sensor is supplied with the following settings:

Continuous Serial Output
RMY Protocol
9600 Baud
Meters per Second

Other settings are easily selected by changing the jumper pattern. Refer to the wiring diagram for jumper J1 and J3 locations. The following table lists available features and position of each jumper.

Important Note:

Jumper settings are read at power-up only. If jumpers are changed, remove and reapply power for the new settings to be used.

In bus mode, commands without the “#” prefix or proper address are ignored. Properly addressed but otherwise invalid commands are responded to as follows:

```
&aaNUc<EOT>   Undefined command
&aaNCc<EOT>   Bad checksum
&aaNOc<EOT>   Other error
```

Where “aa” is the 09101 address in hex, 00-FF; “c” is a single character pseudo-checksum; and <EOT> is the end-of-transmission character (ASCII 4).

In interactive mode, invalid commands produce this response:

NAK<CR/LF>

NCAR PAM III (SUBSET) COMMAND SUMMARY

Upper and lower case text must be observed with these commands.

CMD	DESCRIPTION	RESPONSE
BDddd	Boom direction offset "ddd" is degrees	none
CD	Continuous output, overrides J1	data
FC	Use calibrated speed units	&aaFC
FR	Use raw speed pulse count	&aaFR
MR	Manual reset	reset
OD	Output data	data
OS	Output status	status
PH	Print help (abbreviated command list)	command list
PM	Polled mode, overrides J1	none
PO	Print operating parameters	parameter list
SAaa	Set address, “aa” is new hex address	&aa
ZN	Set zero direction reference	none
calib	Enter calibrate mode*	none
ratexx	Set serial output rate "xx" is the delay between each output in continuous mode. Delay equals the xx value times 32.77 mS. Examples: rate02 is about 16/second rate30 is about once per second	none
propxxx	Set prop pitch "xxx" is prop pitch in mm/rev Example: Use prop294 for model 08234 propeller, 29.4 cm/rev pitch	none

NMEA PROTOCOL

Generally used for marine applications, this protocol produces a standard NMEA output sentence for wind speed and direction at 4800 baud. The sentence is as follows:

\$WIMWV,ddd,R,sss.s,U,A*hh<CR/LF>

“ddd” is wind direction in degrees.

“sss.s” is wind speed.

“U” is wind speed units. N=knots, K=km/h, M=m/s, S=mph

“A” is Status

“*hh” is the hex checksum value of output string

This mode may be used for sending NMEA data to the YOUNG Model 06206 Marine Wind Tracker.

RMYT PROTOCOL

This is a protocol for sending serial wind data directly to a YOUNG Model 06201 Wind Tracker. The output is a special binary format sent 16 times per second at 9600 baud.

VOLTAGE OUTPUTS

Voltage output mode is selected with jumper J3 in the left position. Jumper J1 must be set for RMY, NCAR, or NMEA protocol. Wind direction voltage output calibration is 0-5VDC for 0-540° range. Wind speed voltage output is 0-5VDC for 0-100 meters per second.

In applications where long connection cables or small wire gauge is used, measure the 09101 voltage outputs differentially to overcome error-inducing voltage drops in the cable or consider using the serial RS-485 signal which is more tolerant of this effect.

INSTALLATION

Proper placement of the instrument is very important. Eddies from trees, buildings, or other structures can greatly influence wind speed and wind direction observations. To get meaningful data, locate the instrument well away from obstructions. As a general rule, the air flow around a structure is disturbed to twice the height of the structure upwind, six times the height downwind, and up to twice the height of the structure above ground.

FAILURE TO PROPERLY GROUND THE WIND MONITOR-SE MAY RESULT IN ERRONEOUS SIGNALS OR DAMAGE TO THE UNIT.

Grounding the Wind Monitor is vitally important. Without proper grounding, static electrical charge can build up during certain atmospheric conditions and discharge through the transducers. This discharge can cause erroneous signals or transducer failure. To direct the discharge away from the transducers, it is very important that the sensor be connected to a good earth ground. Inside the junction box connect the terminal labeled EARTH to a good earth ground.

Initial installation is most easily done with two people: one to adjust the instrument position and the other to observe the indicating device. After initial installation, the instrument can be removed and returned to its mounting without realigning the vane since the orientation ring preserves the wind direction reference. Install the Wind Monitor following these steps:

1. MOUNT WIND MONITOR
 - a) Place orientation ring on mounting post. Do Not tighten band clamp yet.
 - b) Place Wind Monitor on mounting post. Do Not tighten band clamp yet.
2. CONNECT SENSOR CABLE
 - a) Remove junction box cover.
 - b) Route cable thru strain relief opening at bottom of junction box. Secure cable by tightening packing nut.
 - c) Connect sensor cable to terminals. See wiring diagram. Terminals A and B are used for either serial (RS-485) or voltage outputs depending on the position of jumper J3. Use a small screwdriver to make connections. Be sure to securely tighten each terminal.
 - d) Replace junction box cover.
3. ALIGN VANE
 - a) Connect instrument to an indicator.
 - b) Choose a known wind direction reference point on the horizon.
 - c) Sighting down instrument centerline, point nose cone at reference point on horizon.
 - d) While holding vane in position, slowly turn base until indicator shows proper value.
 - e) Tighten mounting post band clamp.
 - f) Engage orientation ring indexing pin in notch at instrument base.
 - g) Tighten orientation ring band clamp.

*Max set screw torque 80 oz-in

CALIBRATION

Periodic calibration checks are desirable and may be necessary where the instrument is used in programs which require auditing of sensor performance. Recalibration may be necessary after some maintenance operations.

An accurate wind direction calibration requires a Vane Angle Fixture (Young Model 18112 or equivalent). Details are listed under "VERTICAL SHAFT BEARING REPLACEMENT STEP 10. ALIGN VANE". The sensor nose cone must be removed if any adjustment is required.

Wind speed calibration is determined by propeller pitch and the output characteristics of the transducer. Calibration formulas showing wind speed vs. propeller rpm are shown on the wiring diagram. Standard accuracy is ± 0.3 m/s (0.6mph). For greater accuracy, the device must be individually calibrated in comparison with a wind speed standard. Contact the factory or your YOUNG supplier to schedule a NIST (National Institute of Standards & Technology) traceable wind tunnel calibration in our facility.

To check wind calibration using a signal from the instrument, temporarily remove the propeller and connect an Anemometer Drive to the propeller shaft. Apply the appropriate calibration formula to the calibrating motor rpm and check for the proper value. For example, with the propeller shaft turning at 3600 rpm adjust an indicator to display 17.6 meters per second ($3600 \text{ rpm} \times 0.00490 \text{ m/s/rpm} = 17.6 \text{ m/s}$).

Details on checking bearing torque, which affects wind speed and direction threshold, appear in the following section.

CALIBRATION FORMULAS

Model 09101 Wind Monitor-SE w/08234 Propeller

WIND SPEED vs PROPELLER RPM	
m/s	= 0.00490 x rpm
knots	= 0.00952 x rpm
mph	= 0.01096 x rpm
km/h	= 0.01764 x rpm

MAINTENANCE

Given proper care, the Wind Monitor should provide years of service. The only components likely to need replacement due to normal wear are the precision ball bearings. Only a qualified instrument technician should perform the replacement. If service facilities are not available, return the instrument to the company. Refer to the drawings to become familiar with part names and locations. Maximum torque on all set screws is 80 oz-in.

FLANGE BEARING REPLACEMENT

If anemometer bearings become noisy or wind speed threshold increases above an acceptable level, bearings may need replacement. Check anemometer bearing condition using a Model 18310 Propeller Torque Disc. Without it, a rough check can be performed by adding an ordinary paper clip (0.5 gm) to the tip of a propeller blade. Turn the blade with the paper clip to the "three o'clock" or "nine o'clock" position and gently release it. Failure to rotate due to the weight of the paper clip indicates anemometer bearings need replacement. Repeat this test at different positions to check full bearing rotation. If needed, bearings are replaced as follows.

1. REMOVE OLD BEARINGS
 - a) Unscrew nose cone. Do not lose o-ring seal.
 - b) Loosen set screw on magnet shaft collar and remove magnet.
 - c) Slide propeller shaft out of nose cone assembly.
 - d) Remove front bearing cap which covers front bearing.
 - e) Remove front and rear bearings from nose cone assembly. Insert edge of a pocket knife under bearing flange and lift it out.
2. INSTALL NEW BEARINGS
 - a) Insert new front and rear bearings into nose cone.
 - b) Replace front bearing cap.
 - c) Carefully slide propeller shaft thru bearings.
 - d) Place magnet on propeller shaft allowing 0.5 mm (0.020") clearance from rear bearing.
 - e) Tighten set screw on magnet shaft collar. Do not overtighten.
 - f) Screw nose cone into main housing until o-ring seal is seated. Be certain threads are properly engaged to avoid cross-threading.

VERTICAL SHAFT BEARING REPLACEMENT

Vertical shaft bearings are much larger than the propeller shaft bearings. Ordinarily, these bearings will require replacement less frequently. In many cases, they may last the life of the sensor. Check bearing condition using a Model 18331 Vane Torque Gauge. Without it, a rough check can be performed by holding the instrument with the vane horizontal and placing a 3 gm weight near the aft edge of the fin. Failure of the vane to rotate downward indicates the bearings need replacement.

1. REMOVE MAIN HOUSING
 - a) Unscrew nose cone from main housing. Retain O-ring for reuse.
 - b) Gently push main housing latch.
 - c) While pushing latch, lift main housing up and remove it from vertical shaft bearing rotor.
2. UNSOLDER TRANSDUCER WIRES
 - a) Remove junction box cover.
 - b) Remove 3 screws holding circuit board.
 - c) Unsolder transducer wires from circuit board. 9 wires attach at upper edge of board, 1 wire attaches at bottom near cable terminals.
3. REMOVE TRANSDUCER ASSEMBLY
 - a) Loosen 2 set screws at base of transducer assembly and remove assembly from vertical shaft. Use care to avoid damaging wires.
4. REMOVE BEARING ROTOR by sliding it upward off vertical shaft.
5. REMOVE OLD BEARINGS AND INSTALL NEW BEARINGS. When inserting new bearings, be careful not to apply pressure to bearing shields.
6. REPLACE BEARING ROTOR ON VERTICAL SHAFT
7. REPLACE TRANSDUCER ASSEMBLY. Tighten set screws to 80 oz-in.
8. RECONNECT TRANSDUCER WIRES
 - a) Gently pull wires through hole in junction box. Needle nose pliers or a bent wire may be used.
 - b) Carefully solder wires to circuit board according to wiring diagram. Observe color code.
 - c) Secure circuit board in junction box using 3 screws removed in step 2b. Do not overtighten.

9. REPLACE MAIN HOUSING

- a) Position main housing over bearing rotor. Be careful to align indexing key inside main housing with slot in rotor.
- b) Turn direction-adjust thumbwheel until notch in coupling is away from front opening and aligned with ridge inside housing. Set screw in coupling should face the front opening.
- c) With coupling oriented, continue to push main housing onto bearing rotor until latch locks into place with a click.

10. ALIGN VANE

- a) Connect sensor to indicator.
- b) Install sensor on vane angle fixture (Young Model 18112 or equivalent) with junction box at 180° or South position.
- c) Align sensor to known angular position. If indicator output varies more than ±1 ° from known angle, loosen setscrew in direction adjust thumbwheel and slowly turn thumbwheel until correct output value is obtained. Tighten setscrew.
- d) Verify correct angular values at other vane positions.

11. REPLACE NOSE CONE

- a) Screw nose cone into main housing until o-ring seal is seated. Be careful to avoid cross-threading.

WARRANTY

This product is warranted to be free of defects in materials and construction for a period of 12 months from date of initial purchase. Liability is limited to repair or replacement of defective item. A copy of the warranty policy may be obtained from R. M. Young Company.

CE COMPLIANCE

This product has been tested and shown to comply with European CE requirements for the EMC Directive (see Declaration of Conformity below). Please note that shielded cable must be used.

Declaration of Conformity

R. M. Young Company
2801 Aero Park Drive
Traverse City, MI 49686 USA

Model 09101 Wind Monitor-SE

The undersigned hereby declares on behalf of R. M. Young Company that the above-referenced product, to which this declaration relates, is in conformity with the provisions of:

Council Directive 2004/108/EC (December 15, 2004)
on Electromagnetic Compatibility



David Poinsett
R&D Manager



MODEL 09101 WIND MONITOR-SE

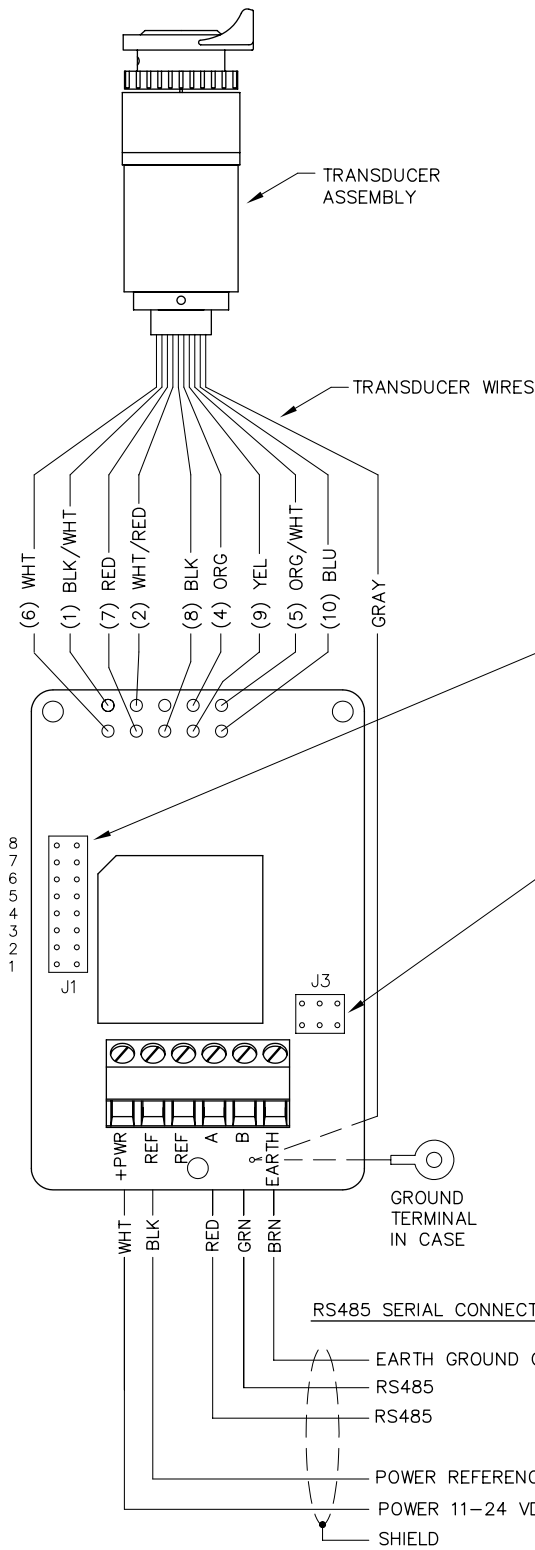
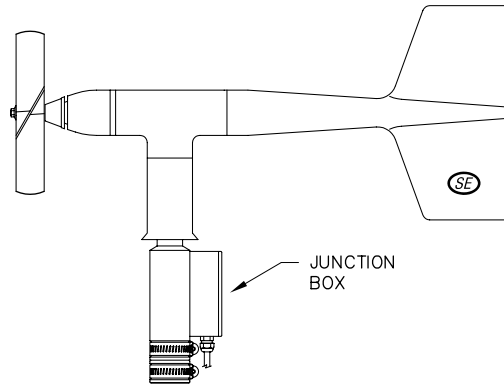

JUMPERS J1 SUMMARY	
DESCRIPTION	JUMPER POSITION
CONTINUOUS SERIAL OUTPUT	1 IN
POLLED SERIAL OUTPUT	1 OUT
RMY PROTOCOL	2 IN 3 IN
NCAR PROTOCOL	2 IN 3 OUT
NMEA PROTOCOL	2 OUT 3 IN
RMYT PROTOCOL	2 OUT 3 OUT
1200 BAUD	4 IN 5 IN
2400 BAUD	4 IN 5 OUT
4800 BAUD	4 OUT 5 IN
9600 BAUD	4 OUT 5 OUT
KNOTS	6 IN 7 IN
MILES PER HOUR	6 IN 7 OUT
KILOMETERS PER HOUR	6 OUT 7 IN
METERS PER SECOND	6 OUT 7 OUT

JUMPERS J3 SUMMARY	
CALIBRATED 0-5 VDC OUTPUT 0-5VDC = 0 - 100 m/sec 0-5VDC = 0 - 540 DEG	<input type="checkbox"/> <input type="checkbox"/> <input type="checkbox"/>
SERIAL RS-485 OUTPUT	<input type="checkbox"/> <input type="checkbox"/> <input type="checkbox"/>

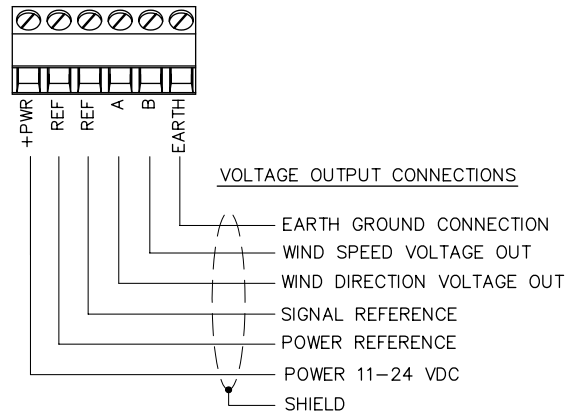

NOTE:
THE EARTH GROUND TERMINAL MUST BE CONNECTED TO EARTH GROUND TO PROVIDE A STATIC DISCHARGE PATH. CONNECT THIS TERMINAL TO AN EARTH GROUND NEAR THE SENSOR.

MODEL 09101 WIND MONITOR	DWG D	PRD 02/98
WIRING DIAGRAM	DWN JMT	DWN 04/11
	CHK <i>[Signature]</i>	W09101(D)
R.M. YOUNG CO. TRAVERSE CITY, MI 49686 U.S.A. 231-946-3980		



WIND MONITOR SECTION VIEW
BEARING REPLACEMENT/POTENTIOMETER ADJUSTMENT

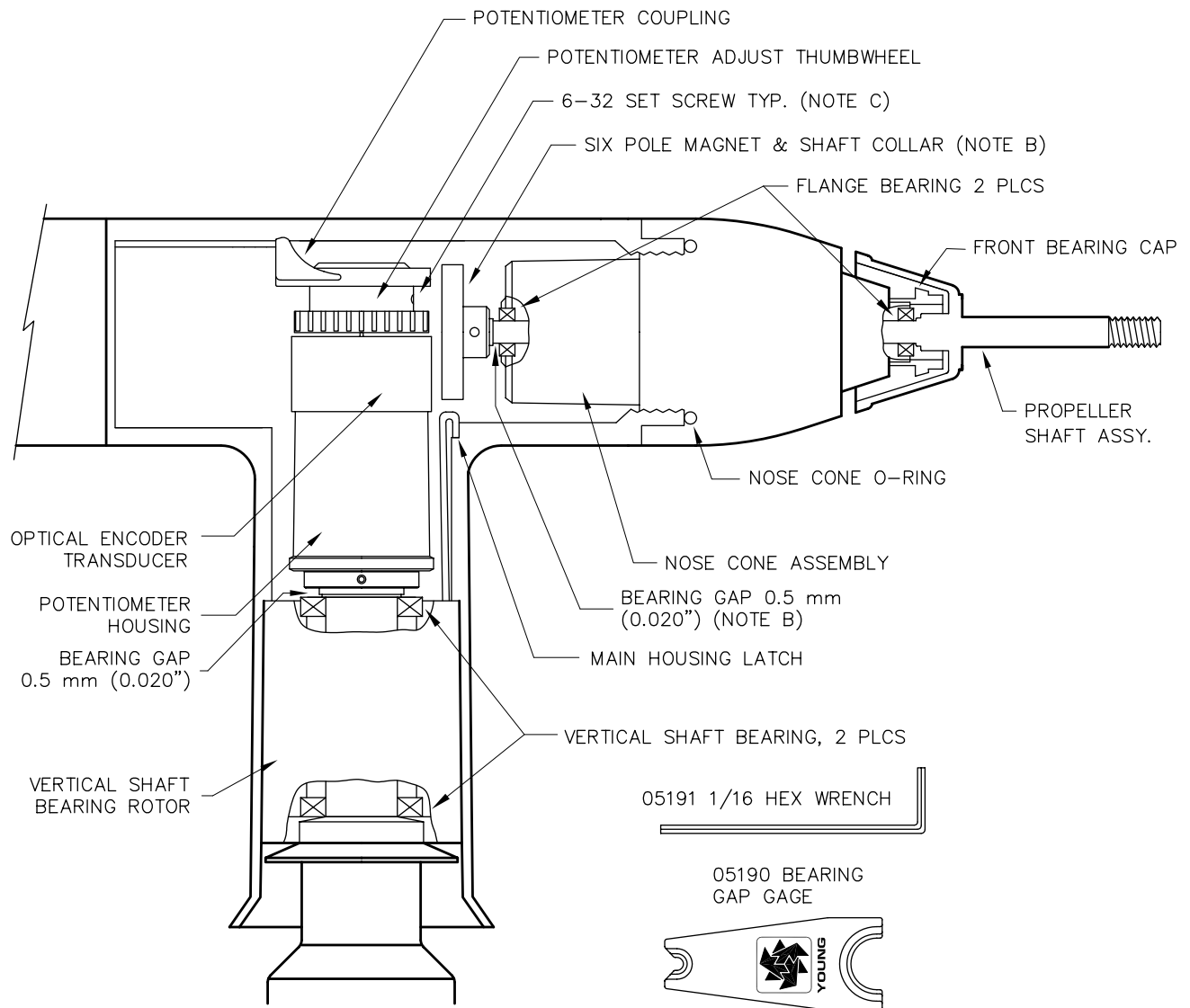

- NOTES:**
- A. TO REMOVE HOUSING – UNTHREAD NOSE CONE ASSEMBLY, PUSH MAIN HOUSING LATCH, LIFT UPWARD.
 - B. TO REPLACE ANEMOMETER FLANGE BEARINGS – UNTHREAD NOSE CONE, REMOVE SIX POLE MAGNET, SLIDE PROPELLER SHAFT AND HUB ASSEMBLY FORWARD, REMOVE FRONT BEARING CAP AND FLANGE BEARINGS. AFTER BEARING REPLACEMENT, SET BEARING GAP TO 0.5mm (0.020")
 - C. TO ADJUST WIND DIRECTION OUTPUT SIGNAL – REMOVE NOSE CONE, LOOSEN SET SCREW IN COUPLING, ADJUST OUTPUT SIGNAL BY MEANS OF ADJUSTMENT THUMBWHEEL, RE-TIGHTEN SET SCREW.

WIND MONITOR-SE SECTION VIEW	DWG B	PRD 02/90
BEARING REPLACEMENT/	DWN JMT	DWN 08/05
WIND DIRECTION ADJUSTMENT	CHK <i>X.C.</i>	S09101(B)
R.M. YOUNG CO. TRAVERSE CITY, MI 49686 U.S.A. 231-946-3980		



MODEL 09101 WIND MONITOR – SE

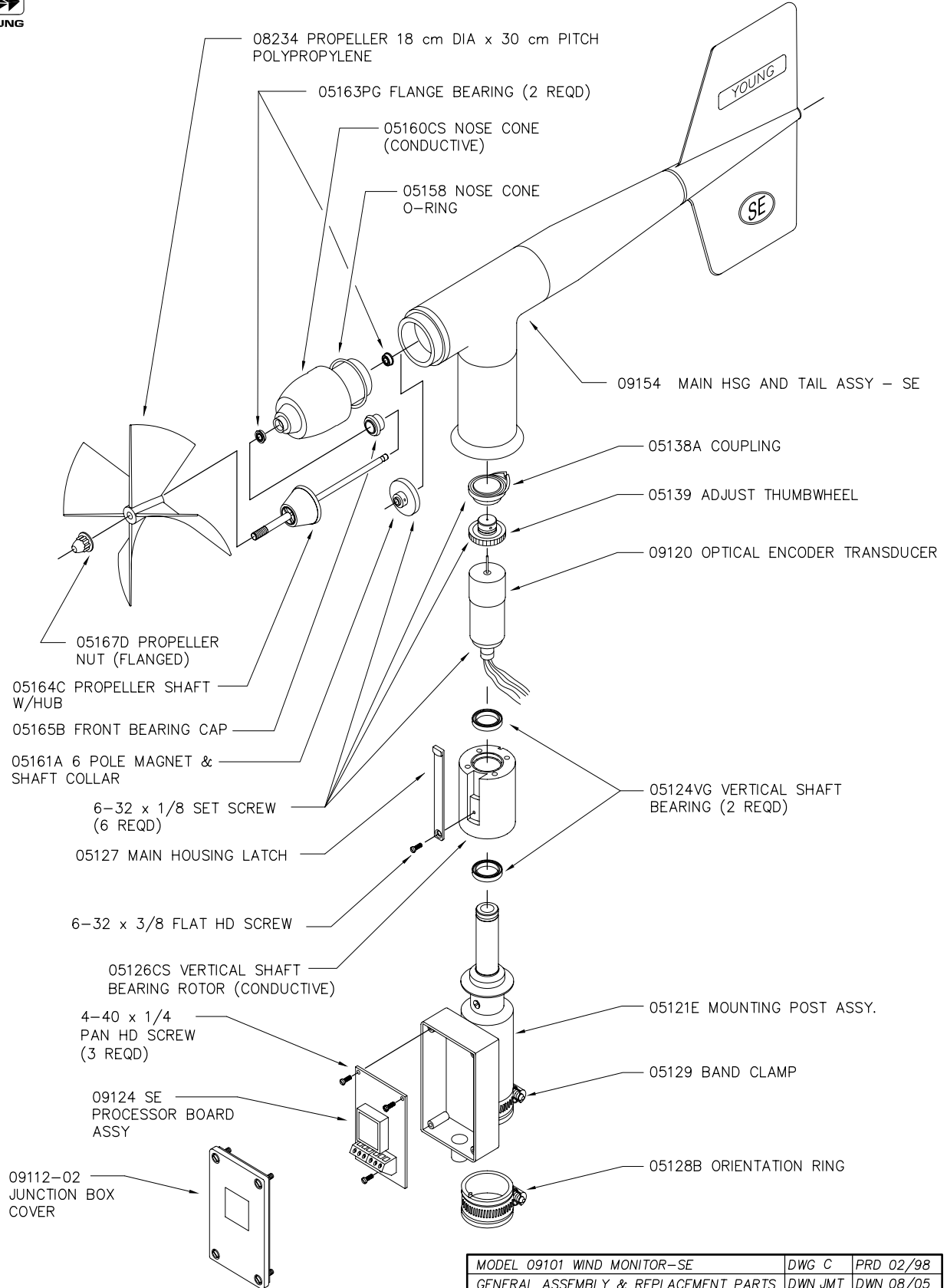

MODEL 09101 WIND MONITOR-SE	DWG C	PRD 02/98
GENERAL ASSEMBLY & REPLACEMENT PARTS	DWN JMT	DWN 08/05
	CHK X.C.	E09101(C)
R.M. YOUNG CO. TRAVERSE CITY, MI 49686 U.S.A. 231-946-3980		

Calibration Accessories

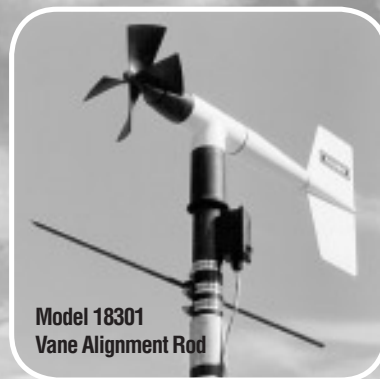
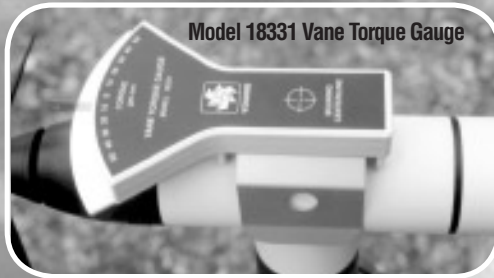

Model 18802 Anemometer Drive provides a convenient and accurate way to rotate an anemometer shaft at a known rate. The motor may be set to rotate clockwise or counter-clockwise at any rate between 200 and 15,000 RPM in 100 RPM increments. The LCD display is referenced to an accurate and stable quartz timebase. For completely portable operation, the unit can be operated on internal batteries. For extended operation, an AC wall adapter is included.

Model 18811 Anemometer Drive is identical to Model 18802 except the drive motor incorporates a gear reducer for operation in the range of 20 to 990 RPM in 10 RPM increments. The lower range is recommended for cup anemometer calibration.

Model 18112 Vane Angle Bench Stand is used for benchtop wind direction calibration of the Wind Monitor family of sensors. The mounting post engages the direction orientation notch on the Wind Monitor. An easy to read pointer indicates 0 to 360 degrees with 1/2 degree resolution.

Model 18212 Vane Angle Fixture - Tower Mount similar to the Model 18112, the tower mount feature allows use on the tower as well as the bench top. The fixture is temporarily placed on the tower between the Wind Monitor and its tower mounting. Index keys and notches are engaged to preserve direction reference.

Model 18310 Propeller Torque Disc checks anemometer bearing torque with 0.1 gm/cm resolution. The disc temporarily replaces the propeller for torque measurement or simple yet accurate pass/fail checks. Charts included with the unit relate torque to propeller threshold with limits for acceptable bearing performance.

Model 18312 Cup-Wheel Torque Disc checks cup anemometer bearing torque.

Model 18331 Vane Torque Gauge checks vane bearing torque of the Wind Monitor family sensors. Slip the fixture over the main housing and make simple yet accurate vane torque measurements. Charts relating vane torque to vane threshold provide limits for acceptable bearing performance.

Model 18301 Vane Alignment Rod helps align the vane of a wind sensor to a known direction reference during installation. The base of the device has an index key that engages the direction orientation notch in the sensor allowing the sensor to be removed without losing wind direction reference.

Specifications

MODEL 18802 ANEMOMETER DRIVE (Replaces 18801)

Range:
200 to 15,000 RPM in 100 RPM increments

Rotation:
Clockwise or Counter-Clockwise

Display Resolution:
1 RPM

Quartz Timebase Reference:
0.1 RPM

Power Requirement:
2x9 V (alkaline or lithium) batteries
115 VAC wall adapter included
(230 VAC – add suffix H)

MODEL 18811 ANEMOMETER DRIVE (Replaces 18810)

Range:
20 to 990 RPM in 10 RPM increments

Display Resolution:
0.1 RPM

MODEL 18112, 18212 VANE ANGLE CALIBRATION DEVICES

Range:
0 to 360 degrees

Resolution:
0.5 degree

MODEL 18310, 18312 TORQUE DISC DEVICES

Range:
0 to 5.4 gm-cm

Resolution:
0.1 gm-cm

MODEL 18331 VANE TORQUE GAUGE

Range:
0 to 50 gm-cm

Resolution:
5 gm-cm

Specifications subject to change without notice.

Ordering Information

MODEL

ANEMOMETER DRIVE 200 to 15,000 RPM	18802
ANEMOMETER DRIVE 20 TO 990 RPM	18811
230V / 50-60 HZ INPUT POWER	ADD SUFFIX "H"
VANE ANGLE BENCH STAND	18112
VANE ANGLE FIXTURE - TOWER MOUNT	18212
PROPELLER TORQUE DISC	18310
CUP-WHEEL TORQUE DISC	18312
VANE TORQUE GAUGE	18331
VANE ALIGNMENT ROD	18301



R. M. YOUNG COMPANY
2801 Aero Park Drive
Traverse City, Michigan 49686 USA
TEL: (231) 946-3980 FAX: (231) 946-4772
E-mail: met.sales@youngusa.com
Web Site: www.youngusa.com