

CMP3

Pyranometer



Limited Warranty

“Products manufactured by CSI are warranted by CSI to be free from defects in materials and workmanship under normal use and service for twelve months from the date of shipment unless otherwise specified in the corresponding product manual. (Product manuals are available for review online at www.campbellsci.com.) Products not manufactured by CSI, but that are resold by CSI, are warranted only to the limits extended by the original manufacturer. Batteries, fine-wire thermocouples, desiccant, and other consumables have no warranty. CSI’s obligation under this warranty is limited to repairing or replacing (at CSI’s option) defective Products, which shall be the sole and exclusive remedy under this warranty. The Customer assumes all costs of removing, reinstalling, and shipping defective Products to CSI. CSI will return such Products by surface carrier prepaid within the continental United States of America. To all other locations, CSI will return such Products best way CIP (port of entry) per Incoterms® 2010. This warranty shall not apply to any Products which have been subjected to modification, misuse, neglect, improper service, accidents of nature, or shipping damage. This warranty is in lieu of all other warranties, expressed or implied. The warranty for installation services performed by CSI such as programming to customer specifications, electrical connections to Products manufactured by CSI, and Product specific training, is part of CSI’s product warranty. **CSI EXPRESSLY DISCLAIMS AND EXCLUDES ANY IMPLIED WARRANTIES OF MERCHANTABILITY OR FITNESS FOR A PARTICULAR PURPOSE. CSI hereby disclaims, to the fullest extent allowed by applicable law, any and all warranties and conditions with respect to the Products, whether express, implied or statutory, other than those expressly provided herein.**”

Assistance

Products may not be returned without prior authorization. The following contact information is for US and international customers residing in countries served by Campbell Scientific, Inc. directly. Affiliate companies handle repairs for customers within their territories. Please visit www.campbellsci.com to determine which Campbell Scientific company serves your country.

To obtain a Returned Materials Authorization (RMA) number, contact CAMPBELL SCIENTIFIC, INC., phone (435) 227-9000. Please write the issued RMA number clearly on the outside of the shipping container. Campbell Scientific's shipping address is:

CAMPBELL SCIENTIFIC, INC.

RMA# _____
815 West 1800 North
Logan, Utah 84321-1784

For all returns, the customer must fill out a "Statement of Product Cleanliness and Decontamination" form and comply with the requirements specified in it. The form is available from our website at www.campbellsci.com/repair. A completed form must be either emailed to repair@campbellsci.com or faxed to (435) 227-9106. Campbell Scientific is unable to process any returns until we receive this form. If the form is not received within three days of product receipt or is incomplete, the product will be returned to the customer at the customer's expense. Campbell Scientific reserves the right to refuse service on products that were exposed to contaminants that may cause health or safety concerns for our employees.

Safety

DANGER — MANY HAZARDS ARE ASSOCIATED WITH INSTALLING, USING, MAINTAINING, AND WORKING ON OR AROUND TRIPODS, TOWERS, AND ANY ATTACHMENTS TO TRIPODS AND TOWERS SUCH AS SENSORS, CROSSARMS, ENCLOSURES, ANTENNAS, ETC. FAILURE TO PROPERLY AND COMPLETELY ASSEMBLE, INSTALL, OPERATE, USE, AND MAINTAIN TRIPODS, TOWERS, AND ATTACHMENTS, AND FAILURE TO HEED WARNINGS, INCREASES THE RISK OF DEATH, ACCIDENT, SERIOUS INJURY, PROPERTY DAMAGE, AND PRODUCT FAILURE. TAKE ALL REASONABLE PRECAUTIONS TO AVOID THESE HAZARDS. CHECK WITH YOUR ORGANIZATION'S SAFETY COORDINATOR (OR POLICY) FOR PROCEDURES AND REQUIRED PROTECTIVE EQUIPMENT PRIOR TO PERFORMING ANY WORK.

Use tripods, towers, and attachments to tripods and towers only for purposes for which they are designed. Do not exceed design limits. Be familiar and comply with all instructions provided in product manuals. Manuals are available at www.campbellsci.com or by telephoning (435) 227-9000 (USA). You are responsible for conformance with governing codes and regulations, including safety regulations, and the integrity and location of structures or land to which towers, tripods, and any attachments are attached. Installation sites should be evaluated and approved by a qualified engineer. If questions or concerns arise regarding installation, use, or maintenance of tripods, towers, attachments, or electrical connections, consult with a licensed and qualified engineer or electrician.

General

- Prior to performing site or installation work, obtain required approvals and permits. Comply with all governing structure-height regulations, such as those of the FAA in the USA.
- Use only qualified personnel for installation, use, and maintenance of tripods and towers, and any attachments to tripods and towers. The use of licensed and qualified contractors is highly recommended.
- Read all applicable instructions carefully and understand procedures thoroughly before beginning work.
- Wear a **hardhat** and **eye protection**, and take **other appropriate safety precautions** while working on or around tripods and towers.
- **Do not climb** tripods or towers at any time, and prohibit climbing by other persons. Take reasonable precautions to secure tripod and tower sites from trespassers.
- Use only manufacturer recommended parts, materials, and tools.

Utility and Electrical

- **You can be killed** or sustain serious bodily injury if the tripod, tower, or attachments you are installing, constructing, using, or maintaining, or a tool, stake, or anchor, come in **contact with overhead or underground utility lines**.
- Maintain a distance of at least one-and-one-half times structure height, 20 feet, or the distance required by applicable law, **whichever is greater**, between overhead utility lines and the structure (tripod, tower, attachments, or tools).
- Prior to performing site or installation work, inform all utility companies and have all underground utilities marked.
- Comply with all electrical codes. Electrical equipment and related grounding devices should be installed by a licensed and qualified electrician.

Elevated Work and Weather

- Exercise extreme caution when performing elevated work.
- Use appropriate equipment and safety practices.
- During installation and maintenance, keep tower and tripod sites clear of un-trained or non-essential personnel. Take precautions to prevent elevated tools and objects from dropping.
- Do not perform any work in inclement weather, including wind, rain, snow, lightning, etc.

Maintenance

- Periodically (at least yearly) check for wear and damage, including corrosion, stress cracks, frayed cables, loose cable clamps, cable tightness, etc. and take necessary corrective actions.
- Periodically (at least yearly) check electrical ground connections.

WHILE EVERY ATTEMPT IS MADE TO EMBODY THE HIGHEST DEGREE OF SAFETY IN ALL CAMPBELL SCIENTIFIC PRODUCTS, THE CUSTOMER ASSUMES ALL RISK FROM ANY INJURY RESULTING FROM IMPROPER INSTALLATION, USE, OR MAINTENANCE OF TRIPODS, TOWERS, OR ATTACHMENTS TO TRIPODS AND TOWERS SUCH AS SENSORS, CROSSARMS, ENCLOSURES, ANTENNAS, ETC.

Table of Contents

PDF viewers: These page numbers refer to the printed version of this document. Use the PDF reader bookmarks tab for links to specific sections.

1. Introduction.....	1
2. Precautions	1
3. Initial Inspection	1
3.1 Ships With.....	1
3.2 Calibration Certificate	1
4. QuickStart	2
5. Overview	4
6. Specifications	5
7. Installation	6
7.1 Siting	6
7.2 Mounting to an Instrument Mount	7
7.2.1 Required Tools.....	7
7.2.2 Mounting Procedure.....	7
7.3 Wiring to the Data Logger	9
7.4 Programming.....	10
7.4.1 Input Range.....	11
7.4.2 Multiplier	12
7.4.3 Offset	12
7.4.4 Output Format Considerations	12
8. Maintenance and Troubleshooting.....	12
8.1 Maintenance/Recalibrations	13
8.2 Troubleshooting	13
 Appendices	
A. Importing Short Cut Code Into CRBasic Editor... A-1	
B. Example Program	B-1
B.1 CR1000X Example Program.....	B-1

Figures

7-1. Pyranometer installation.....6
7-2. CMP3 Schematic.....10

Tables

7-1. Wire Color, Function, and Data Logger Connection.....10
7-2. Multipliers Required for Flux Density and Total Fluxes12

CRBasic Example

B-1. CR1000X Example Program.....B-1

CMP3 Pyranometer

1. Introduction

The CMP3 is an ISO-second-class pyranometer that monitors solar radiation for the full solar spectrum range. It produces a millivolt signal that is measured directly by a Campbell Scientific data logger. The CMP3 can provide solar radiation measurements for a variety of meteorological applications.

NOTE

This manual provides information only for CRBasic data loggers. For Edlog data logger support, see an older manual at www.campbellsci.com/old-manuals.

2. Precautions

- READ AND UNDERSTAND the *Safety* section at the front of this manual.
- CMP3 pyranometer is rugged, but it should be handled as precision scientific instruments.
- Care should be taken when opening the shipping package to not damage or cut the cable jacket. If damage to the cable is suspected, consult with a Campbell Scientific applications engineer.

3. Initial Inspection

- Check the contents of the shipment. If there is a shortage (see Section 3.1, *Ships With (p. 1)*), contact Campbell Scientific. If any damage has occurred during transport, immediately file a claim with the carrier and contact Campbell Scientific to facilitate repair or replacement.
- The model number and cable length are printed on a label at the connection end of the cable. Check this information against the shipping documents to ensure the correct product and cable length are received.

3.1 Ships With

- (2) Bolts for mounting from original manufacturer
- (1) Instruction manual from original manufacturer
- (1) Sun shield from original manufacturer
- (2) Nylon washers from original manufacturer

3.2 Calibration Certificate

Each pyranometer is shipped with an instruction manual provided by Kipp & Zonen that contains information concerning its construction, spectral sensitivity, cosine response, and a simple sensor check out procedure. Included with the sensor and manual is a calibration certificate with the sensor sensitivity value and serial number.

NOTE Cross check this serial number against the serial number on your pyranometer to ensure that the given sensitivity value corresponds to your sensor.

4. QuickStart

A video that describes data logger programming using *Short Cut* is available at: www.campbellsci.com/videos/cr1000x-datalogger-getting-started-program-part-3. *Short Cut* is an easy way to program your data logger to measure this sensor and assign data logger wiring terminals. *Short Cut* is available as a download on www.campbellsci.com. It is included in installations of *LoggerNet*, *RTDAQ*, *PC400*, or *PC200W*.

The following procedure also describes programming with *Short Cut*.

1. Open *Short Cut* and click **Create New Program**.
2. Double-click the data logger model.
3. In the **Available Sensors and Devices** box, type CMP3 or find the sensor in the **Sensors > Meteorological > Solar Radiation** folder. Double-click **CMP3/CMP6/CMP11 Pyranometer**. Default units are kW/m² for flux density units and kJ/m² for total flux. These can be changed by clicking the **Flux Density** and **Total Flux** boxes and selecting different values. A sensitivity value needs to be entered. This value is unique to each sensor and is listed on the calibration sheet that is included with the sensor.

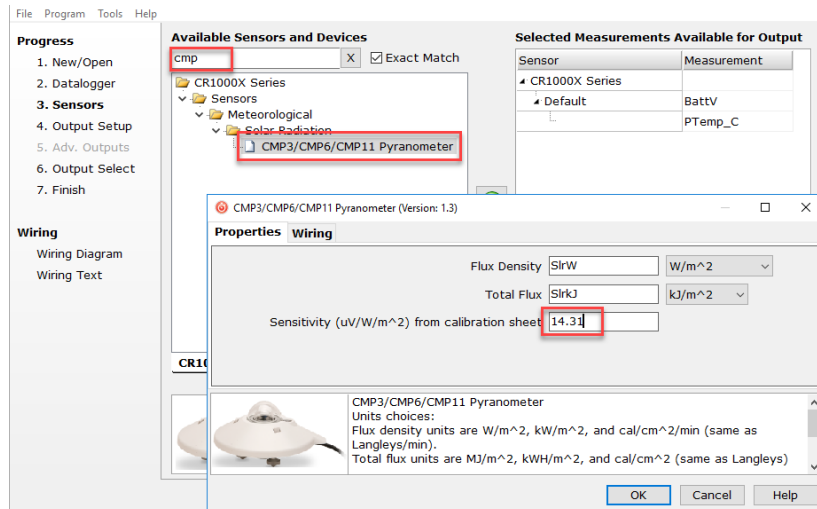

- Click on the **Wiring** tab to see how the sensor is to be wired to the data logger. Click **OK** after wiring the sensor.

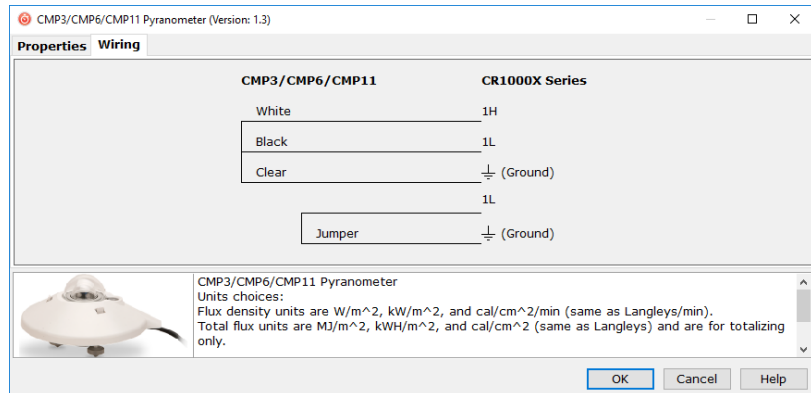

- Repeat steps three and four for other sensors. Click **Next**.
- In **Output Setup**, type the scan rate, meaningful table names, and **Data Output Storage Interval**.

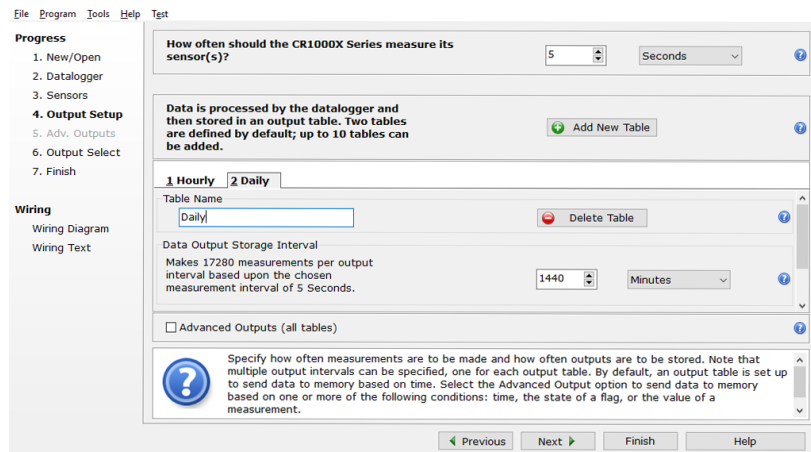

7. Select the output options.

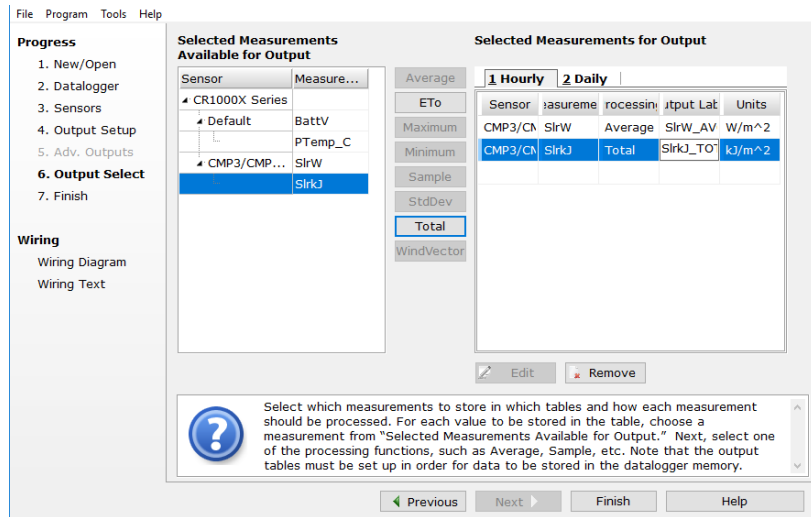

8. Click **Finish** and save the program. Send the program to the data logger if the data logger is connected to the computer.
9. If the sensor is connected to the data logger, as shown in the wiring diagram, check the output of the sensor in the data display in *LoggerNet*, *PC400*, *RTDAQ*, or *PC200W* to make sure it is making reasonable measurements.

NOTE

Short Cut uses the execution interval to make total flux calculations (TABLE 7-2). This needs to be taken into account while editing the *Short Cut* program.

5. Overview

This manual provides information for interfacing the CMP3 Pyranometer to various models of Campbell Scientific data loggers. The CMP3 is manufactured by Kipp & Zonen and then cabled by Campbell Scientific. Cable length is user specified.

The CMP3 pyranometer is designed for continuous outdoor use. Due to its flat spectral sensitivity from 300 to 2800 nm, it can be used in natural sunlight, under plant canopies, in green houses or buildings, and inverted to measure reflected solar radiation. Two CMP3s can be used in combination to measure albedo. The CMP3 can also be used to measure most types of artificial light, such as Xenon lamps or Halogen lamps.

The CMP3 pyranometer consists of a thermopile sensor, housing, dome, and cable. The thermopile is coated with a black absorbent coating. The paint absorbs the radiation and converts it to heat. The resultant temperature difference is converted to a voltage by the copper-constantan thermopile. The thermopile is encapsulated in the housing in such a way that it has a field of view of 180 degrees and the angular characteristics needed to fulfill the cosine response requirements.

Features:

- Includes a white snap-on sun shield that reduces the sensor's temperature
- Provides measurements in direct sunlight, under plant canopies, when the sky is cloudy, and in artificial light
- Measures reflected solar radiation when inverted
- Includes bubble level and leveling screws eliminating need for a separate leveling base, which simplifies installation
- Acceptable for providing the solar radiation data used in stability estimations
- Compatible with Campbell Scientific CRBasic data loggers: CR6, CR3000, CR1000X, CR800-series, CR300-series, CR1000

6. Specifications

ISO classification:	Second Class
Response time 95%:	18 s
Zero offset due to 200 W/m² thermal radiation:	< 15 W/m ²
Zero offset due to temperature change of 5 K / hr:	< ±4 W/m ²
Non stability (% change/year):	< ±1%
Non linearity (0 to 1000 W/m²):	< ±2.5%
Directional error (at 80° with 1000 W/m² beam):	< ±20 W/m ²
Temperature dependence of sensitivity:	±5% (-10 to 40 °C)
Tilt response (±80°) (at 1000 W/m²):	< ±2%
Expected accuracy for daily sums:	±10%
Spectral range (50% points, nm):	300 to 2800 nm
Sensitivity:	5 to 20 μV/(W/m ²)
Typical signal output for atmospheric applications:	0 to 15 mV
Impedance:	30 to 100 Ω
Operating temperature:	-40 to 80 °C

Max. irradiance:	2000 W/m ²
Detector:	Copper-constantan multi junction thermopile
Level accuracy:	1 degree
Dome diameter:	3.2 cm (1.3 in)
Height:	6.7 cm (2.6 in)
Width:	7.9 cm (3.1 in)
Weight:	600 g (1.2 lb)

7. Installation

If you are programming your data logger with *Short Cut*, skip Section 7.3, *Wiring to the Data Logger* (p. 9), and Section 7.4, *Programming* (p. 10). *Short Cut* does this work for you. See Section 4, *QuickStart* (p. 2), for a *Short Cut* tutorial.

7.1 Siting

The CMP3 is usually installed horizontally, but can also be installed at any angle including an inverted position. In all cases, it will measure the flux that is incident on the surface that is parallel to the sensor surface.

Site the CMP3 to allow easy access for maintenance while ideally avoiding any obstructions or reflections above the plane of the sensing element. It is important to mount the CMP3 such that a shadow or reflection will not be cast on it at any time (FIGURE 7-1).

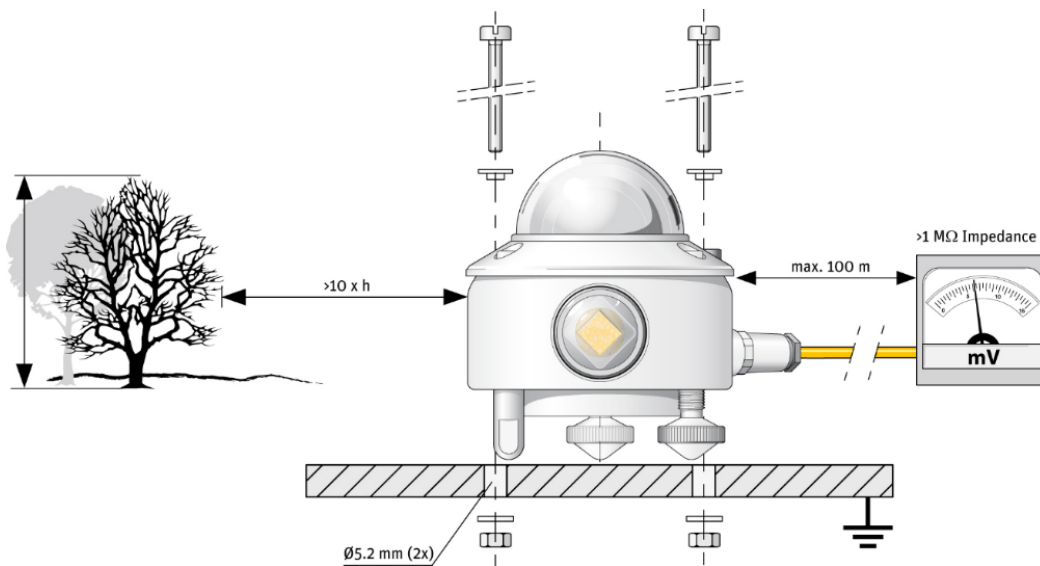

FIGURE 7-1. Pyranometer installation

If this is not possible, try to choose a site where any obstruction over the azimuth range between earliest sunrise and latest sunset has an elevation not exceeding 5°. Diffuse solar radiation is less influenced by obstructions near the horizon. For instance, an obstruction with an elevation of 5° over the whole azimuth range of 360° decreases the downward diffuse solar radiation by only 0.8%.

The sensor should be mounted with the cable pointing towards the nearest magnetic pole. For example, in the northern hemisphere, point the cable toward the North Pole.

7.2 Mounting to an Instrument Mount

7.2.1 Required Tools

Tools required for installation on a tripod or tower:

- Small and medium Phillips screwdrivers
- 8 mm (5/16 in) and 12 mm (1/2 in) open-end wrenches
- 4 mm (5/32 in) Allen wrench
- Tape measure
- UV-resistant wire ties
- Side-cut pliers
- Compass
- Step ladder

7.2.2 Mounting Procedure

The CMP3 is typically mounted to a tripod or tower using the CM225 solar sensor mounting stand. For information about mounting the CMP3 to another mounting stand, refer to the Solar Radiation Sensor Mounts manual.

CAUTION

Mounting the CM225 to a crossarm avoids reflections from the vertical pipe onto the sensor.

1. Mount the crossarm to the tripod or tower.

2. Place the CM225 U-bolt in the bottom holes and secure the CM225 to the crossarm by tightening the U-bolt nuts.

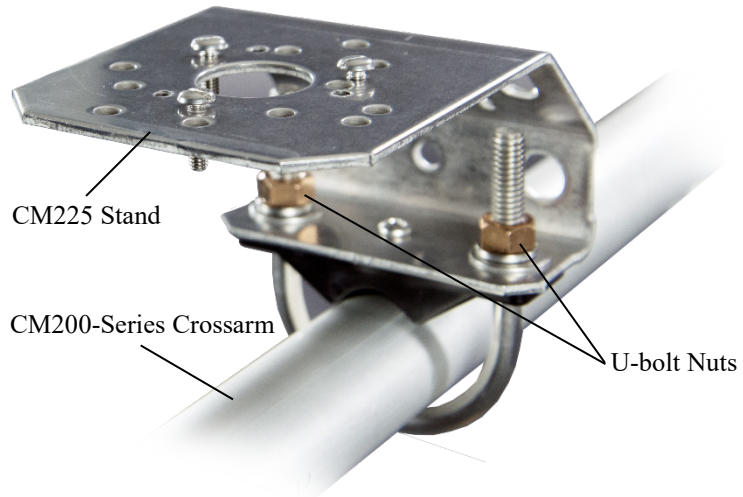

3. Loosely mount the pyranometer on the mounting stand. Do not fully tighten the two mounting screws.

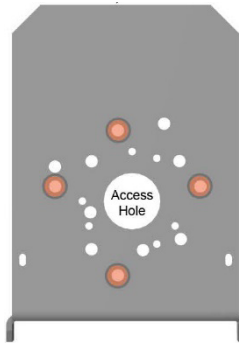

CM225 mounting holes used for the CMP3 are indicated in orange.

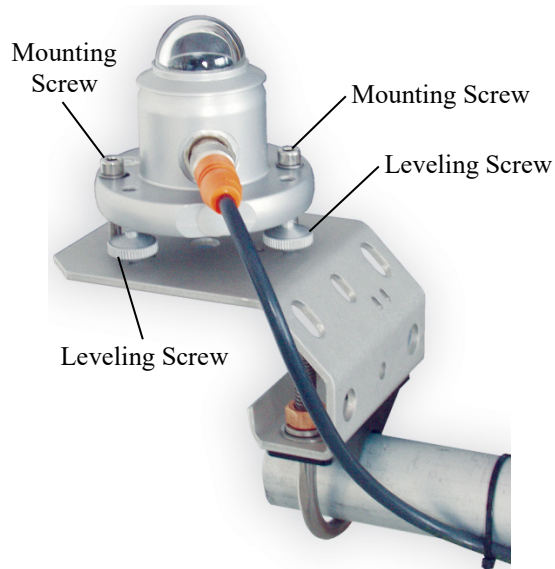

4. Turn the levelling screws as required to bring the bubble of the bubble level within the ring.



5. Tighten the mounting screws to secure the assembly in its final position. Check that the pyranometer is still correctly levelled and adjust as necessary.
6. Attach the white plastic sun shield to the pyranometer.

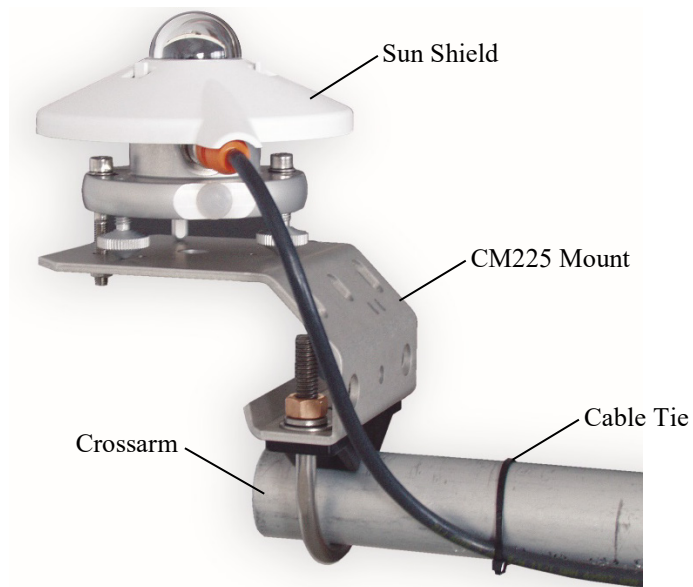

7. Route the sensor cable along the underside of the crossarm to the tripod/tower, and to the instrument enclosure.
8. Secure the cable to the crossarm and mast using cable ties.

7.3 Wiring to the Data Logger

A schematic diagram of the CMP3 is shown in [FIGURE 7-2](#).

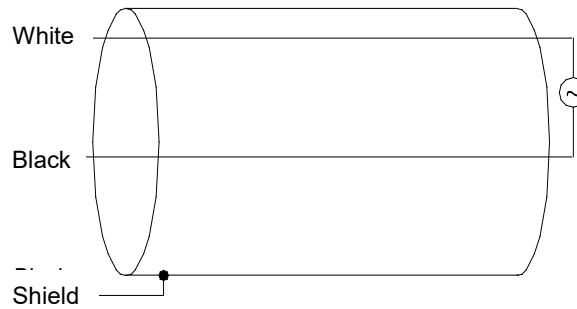

FIGURE 7-2. CMP3 Schematic

NOTE

A CMP3 purchased from Campbell Scientific has different wiring than a CMP3 purchased directly from Kipp & Zonen.

TABLE 7-1 shows connections to Campbell Scientific data loggers. Use either differential or single-ended analog terminals to measure solar radiation. The differential measurement has better noise rejection and is therefore recommended. For differential measurements, a user-supplied jumper wire needs to be connected between the low side of the differential input and ground to keep the signal in common mode range.

TABLE 7-1. Wire Color, Function, and Data Logger Connection			
Wire Color	Wire Function	Differential Data Logger Connection Terminal	Single-Ended Data Logger Connection Terminal
White	Signal High	U configured for differential input ¹ , DIFF H (differential high, analog-voltage input)	U configured for single-ended analog input ¹ , SE (single-ended, analog-voltage input)
Black	Signal Reference	U configured for differential input ^{1, 2} , DIFF L (differential low, analog-voltage input) ²	AG or ⊥ (analog ground)
Clear	Shield	AG or ⊥ (analog ground)	AG or ⊥ (analog ground)
¹ U channels are automatically configured by the measurement instruction. ² Jumper to ⊥ with a user-supplied wire.			

7.4 Programming

Short Cut is the best source for up-to-date data logger programming code.

If your data acquisition requirements are simple, you can probably create and maintain a data logger program exclusively with *Short Cut*. If your data acquisition needs are more complex, the files that *Short Cut* creates are a great

source for programming code to start a new program or add to an existing custom program.

NOTE

Short Cut cannot edit programs after they are imported and edited in *CRBasic Editor*.

A *Short Cut* tutorial is available in Section 4, *QuickStart* (p. 2). If you wish to import *Short Cut* code into *CRBasic Editor* to create or add to a customized program, follow the procedure in Appendix A, *Importing Short Cut Code Into CRBasic Editor* (p. A-1). Programming basics for CRBasic data loggers are provided below. A complete program example can be found in Appendix B, *Example Program* (p. B-1).

Solar radiation can be reported as an average flux density (W/m^2) or daily total flux density (MJ/m^2). The appropriate multipliers are listed in TABLE 7-2. The example reports both average and daily total solar radiation.

The CMP3 outputs a low level voltage ranging from 0 to a maximum of up to 20 mV, in natural light, depending on the calibration factor and radiation level. A differential voltage measurement has better noise rejection than a single-ended measurement. Use a single-ended measurement if a differential terminal is not available. To determine the acceptability of a single-ended measurement, compare the results of single-ended and differential measurements made under the same conditions.

Possible sources of electrical noise include power lines, electric pumps, or motors. If the sensor or data logger is located in an electrically noisy environment, the measurement should be made with the 60 or 50 Hz rejection integration option as shown in Appendix B, *Example Program* (p. B-1).

7.4.1 Input Range

The output voltage is usually between 5 and 20 mV per $1000 \text{ W}/\text{m}^2$. When estimating the maximum likely value of sensor output a maximum value of solar radiation of $1100 \text{ W}/\text{m}^2$ can be used for field measurements on a horizontal surface. Plane of array irradiances can exceed $1500 \text{ W}\cdot\text{m}^{-2}$.

Select the input range as follows:

1. Estimate the maximum expected input voltage by multiplying the maximum expected irradiance (in W/m^2) by the calibration factor ($\mu\text{V} / \text{W}\cdot\text{m}^{-2}$). Divide the answer by 1000 to give the maximum in millivolt units.
2. Select the smallest input range that is greater than the maximum expected input voltage. The exact range will depend on the sensitivity of your individual sensor and the maximum expected reading. With some data loggers an autorange option can be used if measurement time is not critical.

The slow or 60 Hz rejection integration gives a more noise-free reading. A fast integration takes less power and allows for faster throughput.

7.4.2 Multiplier

The multiplier converts the millivolt reading to engineering units. The calibration supplied by the manufacturer gives the output of the sensor (c) as microvolts per W/m². As the data logger voltage measurement instructions give a default output in millivolts, the following equation should be used to calculate the multiplier (m) to give the readings in W/m²:

$$m = 1000/c$$

Other units can be used by adjusting the multiplier as shown in TABLE 7-2.

Units	Multipliers	Output Processing
W/m ²	m	Average
MJ/m ²	$m \times t \times 0.000001$	Total
kJ/m ²	$m \times t \times 0.001$	Total
cal/cm ²	$m \times t \times 0.0239 \times 0.001$	Total
cal/cm ² /min	$m \times 1.434 \times 0.001$	Average
m = calibration factor in W/m ² /mV t = data logger program execution interval in seconds		

7.4.3 Offset

The offset will normally be fixed at zero as the sensor should output no significant signal in dark conditions. In practice, because of the nature of thermopile detector sensors, there will be some offset in dark conditions; sometimes this offset can give negative light readings. This offset varies with several factors, such as rate of change of sensor temperature, so it cannot be removed with a fixed offset. Some users may wish to remove small negative readings by including code after the measurement instructions that sets negative readings to zero.

7.4.4 Output Format Considerations

When using the Campbell Scientific floating point data format to store data, the largest number the data logger can store in final storage is 6999 in low resolution mode (FP2) and 99999 in high resolution mode (if available). If the measurement value is totalized, there is some danger of over-ranging the output limits. To avoid this issue, store the data in the IEEE4 format, which can represent a wider range of numbers.

8. Maintenance and Troubleshooting

NOTE

All factory repairs and recalibrations require a returned material authorization (RMA) and completion of the "Declaration of Hazardous Material and Decontamination" form. Refer to the [Assistance](#) page at the beginning of this manual for more information.

8.1 Maintenance/Recalibrations

Inspect and clean the outer dome every week or so. Clean any accumulated dust or debris off the dome and pyranometer body using a soft cloth dampened with water or alcohol. Check that there is no condensation within the dome.

Check the data returned from the sensor as it will show the first indication of a fault. When doing this you should be aware of several expected phenomena that can cause strange measurements. In particular on clear, windless nights the outer dome temperature of horizontally placed pyranometers can fall as low as the dew point temperature of the air, due to infrared radiation exchange with the cold sky. (The effective sky temperature can be 30 °C lower than the ground temperature, which results in an infrared emission of -150 W/m^2). If this happens, dew, glazed frost or hoar frost can be precipitated on the top of the outer dome and can stay there for several hours in the morning. An ice cap on the dome is a strong diffuser and can increase the pyranometer signal by up to 50% in the first hours after sunrise.

The calibration of the CMP3 may drift with time and exposure to radiation. Campbell Scientific recommends recalibrating every two years. The sensor should be returned to Campbell Scientific, the manufacturer, or a calibration lab with facilities to calibrate radiation sensors.

8.2 Troubleshooting

Symptom: -9999 or radiation values around 0

1. Check that the sensor is wired to the terminal that is specified by the measurement instruction.
2. Verify that the range is correct for the data logger type.
3. Measure the impedance across the red and blue sensor wires. This should be around 100 ohms plus the cable resistance (typically 0.1 ohm/m). If the resistance is very low there may be a short circuit (check the wiring). Resistances somewhat lower than expected could be due to water ingress into the sensor or enclosure connectors. If the resistance is infinite, there is a broken connection (check the wiring).
4. Disconnect the sensor cable and check the voltage output from the sensor. With the sensor located 20 cm (8 inches) below a 60 W incandescent light bulb, the voltage should be approximately 2.5 mV. No voltage indicates a problem with the sensor.

Symptom: sensor signal is unrealistically high or low

1. Check that the right calibration factor has been properly entered into the data logger program. Please note that each sensor has its own individual calibration factor.
2. Check the condition of the sensor cable.

Symptom: sensor signal shows unexpected variations

1. Check for the presence of strong sources of electromagnetic radiation (radar, radio).
2. Check the condition and the connection of the sensor shield wire.
3. Check the condition of the sensor cable.

Appendix A. Importing Short Cut Code Into CRBasic Editor

Short Cut creates a .DEF file that contains wiring information and a program file that can be imported into the *CRBasic Editor*. By default, these files reside in the C:\campbellsci\SCWin folder.

Import *Short Cut* program file and wiring information into *CRBasic Editor*:

1. Create the *Short Cut* program. After saving the *Short Cut* program, click the **Advanced** tab then the **CRBasic Editor** button. A program file with a generic name will open in CRBasic. Provide a meaningful name and save the CRBasic program. This program can now be edited for additional refinement.

NOTE

Once the file is edited with *CRBasic Editor*, *Short Cut* can no longer be used to edit the program it created.

2. To add the *Short Cut* wiring information into the new CRBasic program, open the .DEF file located in the C:\campbellsci\SCWin folder, and copy the wiring information, which is at the beginning of the .DEF file.
3. Go into the CRBasic program and paste the wiring information into it.
4. In the CRBasic program, highlight the wiring information, right-click, and select **Comment Block**. This adds an apostrophe (') to the beginning of each of the highlighted lines, which instructs the data logger compiler to ignore those lines when compiling. The **Comment Block** feature is demonstrated at about 5:10 in the [CRBasic | Features](#) video .

Appendix B. Example Program

The following program measures the CMP3 every 10 s and converts the mV output to W/m² and MJ/m². A sensor calibration of 15.02 μV per W/m² is used for the example program. The program outputs an hourly average flux (W/m²), and a daily total flux density (MJ/m²).

Wiring for the example is given in TABLE B-1.

TABLE B-1. Wiring for Example Program		
Color	Description	CR1000X
White	Signal (+)	1H
Black	Signal (-)	1L
Shield	Shield	⊥
¹ Jumper to ⊥ with user-supplied wire.		

B.1 CR1000X Example Program

```

CRBasic Example B-1. CR1000X Example Program

'CR1000X

'Declare Variables and Units
Public Solar_Wm2
Public Solar_MJ

Units Solar_Wm2=W/m^2
Units Solar_MJ=MJ/m^2

'Hourly Data Table
DataTable(Hourly,True,-1)
  DataInterval(0,60,Min,10)
  Average(1,Solar_Wm2,FP2,False)
EndTable

'Daily Data Table
DataTable(Daily,True,-1)
  DataInterval(0,1440,Min,10)
  Totalize(1,Solar_MJ,IEEE4,False)
EndTable

'Main Program
BeginProg
  Scan(10,Sec,1,0)

  'CMP3 Pyranometer measurement in W/m^2:

  'The Multiplier (m) for this example is based upon a sensor calibration (c) of
  '15.02 μV/Wm-2, and will be different for each sensor.
  'Multiplier (m) = 1000/c = 66.577896.

  VoltDiff(Solar_Wm2,1,mV200,1,True,0,60,66.577896,0) 'use mV50 for the CR3000
  'and mV34 for the CR300-series

  'Set negative readings to zero:

```

```
If Solar_Wm2<0 Then Solar_Wm2=0

'Calculate units in MJ, where MJ = m * t * 0.000001. m = Solar_Wm2 from above, and
't = 10 (scan interval)

Solar_MJ=Solar_Wm2*0.00001

'Call Data Tables and Store Data
CallTable(Hourly)
CallTable(Daily)
NextScan
EndProg
```



Global Sales & Support Network

A worldwide network to help meet your needs



Australia

Location: Garbutt, QLD Australia
Phone: 61.7.4401.7700
Email: info@campbellsci.com.au
Website: www.campbellsci.com.au

Brazil

Location: São Paulo, SP Brazil
Phone: 11.3732.3399
Email: vendas@campbellsci.com.br
Website: www.campbellsci.com.br

Canada

Location: Edmonton, AB Canada
Phone: 780.454.2505
Email: dataloggers@campbellsci.ca
Website: www.campbellsci.ca

China

Location: Beijing, P. R. China
Phone: 86.10.6561.0080
Email: info@campbellsci.com.cn
Website: www.campbellsci.com

Costa Rica

Location: San Pedro, Costa Rica
Phone: 506.2280.1564
Email: info@campbellsci.cc
Website: www.campbellsci.cc

France

Location: Vincennes, France
Phone: 0033.0.1.56.45.15.20
Email: info@campbellsci.fr
Website: www.campbellsci.fr

Germany

Location: Bremen, Germany
Phone: 49.0.421.460974.0
Email: info@campbellsci.de
Website: www.campbellsci.de

India

Location: New Delhi, DL India
Phone: 91.11.46500481.482
Email: info@campbellsci.in
Website: www.campbellsci.in

South Africa

Location: Stellenbosch, South Africa
Phone: 27.21.8809960
Email: sales@campbellsci.co.za
Website: www.campbellsci.co.za

Spain

Location: Barcelona, Spain
Phone: 34.93.2323938
Email: info@campbellsci.es
Website: www.campbellsci.es

Thailand

Location: Bangkok, Thailand
Phone: 66.2.719.3399
Email: info@campbellsci.asia
Website: www.campbellsci.asia

UK

Location: Shepshed, Loughborough, UK
Phone: 44.0.1509.601141
Email: sales@campbellsci.co.uk
Website: www.campbellsci.co.uk

USA

Location: Logan, UT USA
Phone: 435.227.9120
Email: info@campbellsci.com
Website: www.campbellsci.com