

INSTRUCTION MANUAL



CS135 Ceilometer

6/16



Copyright © 2016
Campbell Scientific, Inc.

Limited Warranty

“Products manufactured by CSI are warranted by CSI to be free from defects in materials and workmanship under normal use and service for twelve months from the date of shipment unless otherwise specified in the corresponding product manual. (Product manuals are available for review online at www.campbellsci.com.) Products not manufactured by CSI, but that are resold by CSI, are warranted only to the limits extended by the original manufacturer. Batteries, fine-wire thermocouples, desiccant, and other consumables have no warranty. CSI’s obligation under this warranty is limited to repairing or replacing (at CSI’s option) defective Products, which shall be the sole and exclusive remedy under this warranty. The Customer assumes all costs of removing, reinstalling, and shipping defective Products to CSI. CSI will return such Products by surface carrier prepaid within the continental United States of America. To all other locations, CSI will return such Products best way CIP (port of entry) per Incoterms ® 2010. This warranty shall not apply to any Products which have been subjected to modification, misuse, neglect, improper service, accidents of nature, or shipping damage. This warranty is in lieu of all other warranties, expressed or implied. The warranty for installation services performed by CSI such as programming to customer specifications, electrical connections to Products manufactured by CSI, and Product specific training, is part of CSI’s product warranty. **CSI EXPRESSLY DISCLAIMS AND EXCLUDES ANY IMPLIED WARRANTIES OF MERCHANTABILITY OR FITNESS FOR A PARTICULAR PURPOSE. CSI hereby disclaims, to the fullest extent allowed by applicable law, any and all warranties and conditions with respect to the Products, whether express, implied or statutory, other than those expressly provided herein.”**

Assistance

Products may not be returned without prior authorization. The following contact information is for US and international customers residing in countries served by Campbell Scientific, Inc. directly. Affiliate companies handle repairs for customers within their territories. Please visit www.campbellsci.com to determine which Campbell Scientific company serves your country.

To obtain a Returned Materials Authorization (RMA), contact CAMPBELL SCIENTIFIC, INC., phone (435) 227-9000. Please write the issued RMA number clearly on the outside of the shipping container. Campbell Scientific's shipping address is:

CAMPBELL SCIENTIFIC, INC.

RMA# _____
815 West 1800 North
Logan, Utah 84321-1784

For all returns, the customer must fill out a "Statement of Product Cleanliness and Decontamination" form and comply with the requirements specified in it. The form is available from our website at www.campbellsci.com/repair. A completed form must be either emailed to repair@campbellsci.com or faxed to (435) 227-9106. Campbell Scientific is unable to process any returns until we receive this form. If the form is not received within three days of product receipt or is incomplete, the product will be returned to the customer at the customer's expense. Campbell Scientific reserves the right to refuse service on products that were exposed to contaminants that may cause health or safety concerns for our employees.

Safety

DANGER — MANY HAZARDS ARE ASSOCIATED WITH INSTALLING, USING, MAINTAINING, AND WORKING ON OR AROUND TRIPODS, TOWERS, AND ANY ATTACHMENTS TO TRIPODS AND TOWERS SUCH AS SENSORS, CROSSARMS, ENCLOSURES, ANTENNAS, ETC. FAILURE TO PROPERLY AND COMPLETELY ASSEMBLE, INSTALL, OPERATE, USE, AND MAINTAIN TRIPODS, TOWERS, AND ATTACHMENTS, AND FAILURE TO HEED WARNINGS, INCREASES THE RISK OF DEATH, ACCIDENT, SERIOUS INJURY, PROPERTY DAMAGE, AND PRODUCT FAILURE. TAKE ALL REASONABLE PRECAUTIONS TO AVOID THESE HAZARDS. CHECK WITH YOUR ORGANIZATION'S SAFETY COORDINATOR (OR POLICY) FOR PROCEDURES AND REQUIRED PROTECTIVE EQUIPMENT PRIOR TO PERFORMING ANY WORK.

Use tripods, towers, and attachments to tripods and towers only for purposes for which they are designed. Do not exceed design limits. Be familiar and comply with all instructions provided in product manuals. Manuals are available at www.campbellsci.com or by telephoning (435) 227-9000 (USA). You are responsible for conformance with governing codes and regulations, including safety regulations, and the integrity and location of structures or land to which towers, tripods, and any attachments are attached. Installation sites should be evaluated and approved by a qualified engineer. If questions or concerns arise regarding installation, use, or maintenance of tripods, towers, attachments, or electrical connections, consult with a licensed and qualified engineer or electrician.

General

- Prior to performing site or installation work, obtain required approvals and permits. Comply with all governing structure-height regulations, such as those of the FAA in the USA.
- Use only qualified personnel for installation, use, and maintenance of tripods and towers, and any attachments to tripods and towers. The use of licensed and qualified contractors is highly recommended.
- Read all applicable instructions carefully and understand procedures thoroughly before beginning work.
- Wear a **hardhat** and **eye protection**, and take **other appropriate safety precautions** while working on or around tripods and towers.
- **Do not climb** tripods or towers at any time, and prohibit climbing by other persons. Take reasonable precautions to secure tripod and tower sites from trespassers.
- Use only manufacturer recommended parts, materials, and tools.

Utility and Electrical

- **You can be killed** or sustain serious bodily injury if the tripod, tower, or attachments you are installing, constructing, using, or maintaining, or a tool, stake, or anchor, come in **contact with overhead or underground utility lines**.
- Maintain a distance of at least one-and-one-half times structure height, 20 feet, or the distance required by applicable law, **whichever is greater**, between overhead utility lines and the structure (tripod, tower, attachments, or tools).
- Prior to performing site or installation work, inform all utility companies and have all underground utilities marked.
- Comply with all electrical codes. Electrical equipment and related grounding devices should be installed by a licensed and qualified electrician.

Elevated Work and Weather

- Exercise extreme caution when performing elevated work.
- Use appropriate equipment and safety practices.
- During installation and maintenance, keep tower and tripod sites clear of un-trained or non-essential personnel. Take precautions to prevent elevated tools and objects from dropping.
- Do not perform any work in inclement weather, including wind, rain, snow, lightning, etc.

Maintenance

- Periodically (at least yearly) check for wear and damage, including corrosion, stress cracks, frayed cables, loose cable clamps, cable tightness, etc. and take necessary corrective actions.
- Periodically (at least yearly) check electrical ground connections.

WHILE EVERY ATTEMPT IS MADE TO EMBODY THE HIGHEST DEGREE OF SAFETY IN ALL CAMPBELL SCIENTIFIC PRODUCTS, THE CUSTOMER ASSUMES ALL RISK FROM ANY INJURY RESULTING FROM IMPROPER INSTALLATION, USE, OR MAINTENANCE OF TRIPODS, TOWERS, OR ATTACHMENTS TO TRIPODS AND TOWERS SUCH AS SENSORS, CROSSARMS, ENCLOSURES, ANTENNAS, ETC.

Contents

PDF viewers note: These page numbers refer to the printed version of this document. Use the Adobe Acrobat® bookmarks tab for links to specific sections.

Section 1. General Information	1
1.1 General Safety	1
1.2 Sensor Unit Safety	1
1.3 Laser Safety.....	2
1.4 Electrical Safety	3
Section 2. Product Overview	3
2.1 Introduction	4
2.1.1 Overview.....	4
2.1.2 Cloud height detection	5
2.1.3 Sky condition	6
2.1.4 Backscatter profile	6
2.1.5 Mixing layer height.....	7
2.2 Optical Measurement	7
2.2.1 Optical Arrangement.....	7
2.3 Internal Monitoring	8
2.4 Specifications.....	8
2.4.1 Measurement Specifications	8
2.4.2 Mechanical Specifications	8
2.4.3 Electrical Specifications	8
2.4.4 Optical Specifications.....	9
2.4.5 Environmental Specifications.....	10
2.4.6 Communications Specifications.....	10
Section 3. Initial preparation and checks	11
Section 4. Installation	12
4.1 Location and Orientation	12
4.2 Grounding	12
4.3 Mounting the CS135	12
4.4 Tilt Angle	14
4.5 Connectors and wiring	15
4.5.1 Base connectors.....	15
4.5.2 Wiring using supplied Campbell Scientific Cables	16
4.5.3 USB connection	18
4.5.4 SDI-12 connection	18
4.6 Connecting the Back-up Battery.....	19
4.6.1 Removing the Cover.....	20
4.6.2 Removing the Enclosure Lid	20
4.7 Bird Spike Kit.....	21
4.8 Storage Information	22
Section 5. Operation	23
5.1 Terminal Mode	23
5.1.1 Entering / Exiting the CS135 Terminal Mode	23
5.1.2 Terminal Mode Commands General.....	23

5.1.3 Terminal Mode Command Examples	24
5.1.4 MCFG Command Message Types.....	31
5.1.5 Measurement and message intervals	32
5.1.6 STATUS Command	32
5.1.7 Message Polling	36
5.1.8 Loading a New Operating System (OS)	37
5.1.9 Stratocumulus backscatter calibration	39
5.1.10 CRC Codes on terminal commands.....	40
5.1.11 Service command	41
5.1.12 Locked features.....	42
5.2 Restoring Factory Defaults.....	42
5.3 LED Indicator	43

Section 6. Messages..... 43

6.1 Data Messages General.....	43
6.2 Checksums used in CS135 messages	43
6.3 CS Messages	45
6.4 CL31 Messages	64
6.5 CT25K Messages.....	73

Section 7. Maintenance 78

7.1 General	78
7.2 Cleaning.....	78
7.3 Removing the Cover	79
7.4 Removing the Enclosure Lid.....	80
7.5 Diagnostic LED Indicators Within the Enclosure.....	81
7.6 Electrical Safety Testing	82
Packing List	

Figures

2-1. CS135 Ceilometer	3
2-2. CS135 Dimensions.....	4
2-3. Principle of operation	7
2-4. PSU Types	9
4-1. Mounting footprint.....	13
4-2. Setting the tilt angle.....	14
4-3. Connector layout	15
4-4. Cable Connections	18
4-5. USB port	19
4-6. Connecting Battery.....	19
4-7. Removing the cover.....	20
4-8. Removing the enclosure lid	20
4-9. CS135 Bird Spike Kit installed.....	21
4-10. Preparing the CS135 for Installing the Bird Spikes.....	22
4-11. Attaching Bird Spikes to the CS135 cowl	22
5-1. Restoring factory defaults	42
5-2. LED indicator	43
7-1. Removing the cover.....	79
7-2. Removing the enclosure lid	80
7-3. Diagnostic LED indicators	81

Tables

4-1. Function of the connector pins	16
5-1. Summary of the terminal mode commands available.....	25

Appendix

A. Example CRBasic programs.....	A-1
B. Measurement of the attenuated backscatter profile	B-1
C. Cloud height calculation.....	C-1
D. Sky condition algorithm description	D-1

CS135 Ceilometer



Important Safety Instructions – please request a translation or further advice if you cannot understand this document.

Wichtige Sicherheitshinweise - bitte kontaktieren Sie uns bzgl. einer Übersetzung falls Sie Schwierigkeiten haben Inhalte dieses Dokumentes zu verstehen.

Consignes de sécurité importantes - N'hésitez pas à demander un avis ou une traduction, si vous ne pouvez pas comprendre ce document.

Instrucciones de Seguridad Importantes – solicite por favor traducción o asesoramiento adicional si no entiende este documento.

Istruzioni di sicurezza importanti - chiedi prego una traduzione o avanti il consiglio se non potete capire questo documento.

Instruções de segurança importantes - por favor, solicitar uma tradução ou conselho mais se você não consegue entender este documento.

1. General Information

1.1 General Safety

This manual provides important safety considerations for the installation, operation and maintenance of the CS135. These safety considerations are classified into three levels:

WARNING	Warnings alert the installer or user to serious hazards. Ignoring these warnings could result in injury or death and/or irrevocable damage to the sensor unit.
CAUTION	Cautions warn of potential hazards. Ignoring these cautions could result in the sensor being damaged and data being lost.
NOTE	Notes highlight useful information in the installation, use and maintenance of this product. These should be followed carefully in order to gain the maximum benefit from the use of this product.

1.2 Sensor Unit Safety

The CS135 sensor has been checked for safety before leaving the factory and contains no internally replaceable or modifiable parts.

WARNING Do not modify the CS135 unit. Such modifications will lead to damage of the unit and could expose users to dangerous light levels and voltages.

WARNING Do not attempt to repair the CS135 unit without consulting Campbell Scientific.

CAUTION Ensure that the correct voltage supply is provided to the sensor.

1.3 Laser Safety

The CS135 sensor incorporates a InGaAs laser diode which is rated as a class 3B device. This is an embedded laser where the output from the sensor unit, through the optics, is minimised to class 1M. This classification indicates that viewing of the beam with the naked eye is safe but looking directly into the beam with optical instruments, e.g. binoculars can be dangerous.

From the laser head the output has the following characteristics:

Maximum pulse energy: 4800 nJ

Pulse duration: 100 ns

Pulse frequency: 10 kHz

Wavelength: 905 nm

EN 60825-1:2001

The sensor is marked with the following warning:

**INVISIBLE LASER RADIATION
DO NOT VIEW DIRECTLY WITH OPTICAL INSTRUMENTS
CLASS 1M LASER PRODUCT**

WARNING Removing the laser module with the power applied to the CS135 or battery connected may expose the user to hazardous class 3B laser radiation.

No attempt should be made to operate the laser module outside of the housing.

WARNING Check that the laser warning label on the sensor is still visible and can be clearly read on an annual basis.

When installing the sensor avoid pointing the laser housing towards areas where binoculars are in common use.

1.4 Electrical Safety

As the sensor is powered from potentially hazardous mains voltages the wiring of its power supply should only be carried out by personnel qualified to install electrical equipment. For permanent installations outside, this usually requires a certified electrician who is also familiar with local electrical and safety legislation. Some general guidance is given in Section 5.5, but the responsibility for the installation lies with that installer.

The unit is tested for electrical safety before despatch but may need subsequent testing according to local practice.

NOTE

The unit should only be serviced by trained personnel.

WARNING

Removal of electronic module covers or connectors while the unit is powered will expose the operator to potentially hazardous voltages and risk damage to the sensor.

2. Product Overview



Fig 2.1 CS135 Ceilometer

2.1 Introduction

2.1.1 Overview

The CS135 is a LIDAR (LIght Detection And Ranging). It emits short pulses of near infra-red light into the atmosphere from a semiconductor laser. These are scattered back by aerosols including cloud droplets. The time between transmission of the pulse and the return signal gives the range, and therefore height, of the scattering aerosols. The variation in the strength of the back-scattered light signal with height gives a profile of scatter coefficients and allow cloud bases to be identified. If significant scattering is detected but there is no defined cloud base then a vertical visibility can be calculated.

The control system of the CS135 is divided into three modules, DSP, TOP and PSU as follows:

DSP is the main data processing and communications unit of the CS135.

The DSP hosts two separate time keeping circuits. These are cross checked and an alarm produced if they disagree.

TOP provides a number of safety shutdown features such as over and under laser output level. It also contains the calibration circuitry and dirty windows system.

PSU controls the power supply, including battery charging and deep discharge protection.

The CS135 has a rugged environmental enclosure that protects the instrument from the harshest conditions and will measure the atmosphere with high stability and repeatability.

2.1.2 Cloud height detection

A scatter profile is measured as described in Appendix B.

Cloud height detection is carried out as described in Appendix C. Up to four cloud heights can be detected.

If no clouds are detected the CS135 will give one of the following reports:

- No significant backscatter.
- Full obscuration determined but no cloud base detected. This is reported if the criteria for detecting cloud base is not met but the integrated scattering coefficient reaches the limit of vertical visibility below a set height limit. The default value is 2000 m but can be changed by the user. The height at which this occurs is given as vertical visibility.
- Some obscuration detected but determined to be transparent is reported if scattering is detected but no cloud is detected and the calculated vertical visibility exceeds a set height limit.

If no cloud is detected but significant scattering is detected below 50 m then vertical visibility is set to 0.

2.1.3 Sky Condition

Sky condition is an assessment of cloud cover measured in units of eighths or 'oktas'. The number of oktas is the density of cloud in eighths of that layer. Up to 5 layers can be output by the CS135. The algorithm used in the CS135 follows guidance in ICAO 9837, Manual on Automatic Meteorological Observing Systems at Aerodromes.

Note that sky condition assessment is based on cloud data for the previous 30 minutes, with cloud detection in the previous 10 minutes given an extra weighting and is not an instantaneous measurement. Therefore it will not be available before sufficient data has been collected. See Appendix D for more detail.

2.1.4 Backscatter profile reporting

Several possible data messages give the two-way attenuated backscatter profile. This consists of 2048 groups of five-character hexadecimal values (10240 characters in total). Each character is 4 bits long and therefore each 5 figure group is 20 bits. They are given as signed two's complement integers and numbers greater than $2^{19}-1$ represent negative integers.

Therefore each group actually represents negative a value between -2^{19} to $+(2^{19}-1)$, rather than 0 to $(2^{20}-1)$, which would be the case for unsigned, positive, 20-bit integers.

In order to translate this to the correct decimal value, a two stage process should be applied. This is as follows:

- (1) Convert from a hexadecimal to a decimal number.
- (2) If the resulting decimal number lies in the range 0 to 524287 ($2^{19}-1$) then nothing further needs to be done. If the number resulting from this conversion is greater than 524287 then subtract 1048576 (2^{20}).

In order to use this backscatter coefficient in units of $\text{sr}^{-1} \text{m}^{-1}$ this calculated decimal number has to be multiplied by a factor of 10^{-8} . The values are scaled by the *Attenuated_SCALE* parameter, see Table 5.1.

NOTE The last two values of the profile will always be zero by design (they are beyond the 10 km range of the instrument).

NOTE The profile is not corrected for tilt angle even if cloud heights are corrected.

2.1.5 Mixing layer height

A Mixing Layer Height measurement option is available. This retrieves the height of the mixed aerosol layer by applying the gradient method to the ceilometer's backscatter signal. This approach, based on the operational algorithm used by KNMI*, searches for the drop in backscatter associated with the transition from boundary layer aerosols to free troposphere. Since the signals measured depend on the type and amount of aerosol present as well as the background light level, the accuracy of the method varies and therefore a quality

factor is assigned which indicates the confidence in the reported layer height. The module is also capable of indicating the top of residual layers and aerosol layers aloft. To activate this option please contact Campbell Scientific.

This is a guide to how well the mixing layer is defined on a scale 1 to 3 (3 is best). It is determined by the magnitude of the difference between the average backscatter over a distance below the MLH and the average backscatter over a distance above the MLH.

Haij, M.J. de, H. Klein Baltink and W.M.F. Wauben: Continuous mixing layer height determination using the LD-40 ceilometer: a feasibility study, Scientific Report WR 2007-01, KNMI, De Bilt, 2007.

2.2 Optical Measurement

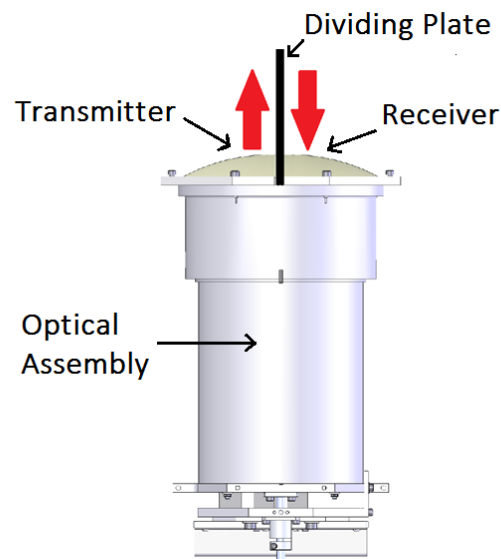

Fig 2.2 Principle of operation

2.2.1 Optical Arrangement

The CS135 employs a novel split-lens design to increase optical signal to noise ratio while maintaining Class 1M eye safety by integrating larger optics into a compact package (see Fig 2.2). A lens is split and the halves divided by a dividing plate. One half is used by the transmitter, the other by the receiver. They are therefore very close. This design provides an alternative to traditional biaxial or common-optics designs. The optical isolation of traditional biaxial systems is maintained to increase detector sensitivity, while the low overlap onset height of common-optics systems is incorporated to allow measurements at close ranges.

2.3 Internal Monitoring

The CS135 monitors a large number of parameters relevant to its performance. These include window contamination, key voltages and currents and internal temperature and relative humidity. Data messages, see Section 5, include this information allowing remote diagnosis of the CS135 condition. In addition a special status message can be polled.

2.4 Specifications

2.4.1 Measurement Specifications

Maximum Reporting Range: 10 km / 32,800 ft

Minimum Reporting Resolution: 5 m / 15 ft

Hard Target Range Accuracy: +/- 0.25% +/- 4.6 m

Reporting Cycle: 2 to 600s

Cloud Layers Reported: Up to four layers reported.

2.4.2 Mechanical Specifications

Height: 1000 mm

Width: 327 mm

Depth: 281 mm

Total weight: 33 kg (excluding cables)

Packed weight: 58 kg

Maximum windspeed: 55 m/s (shown by static load testing and survival in field use).

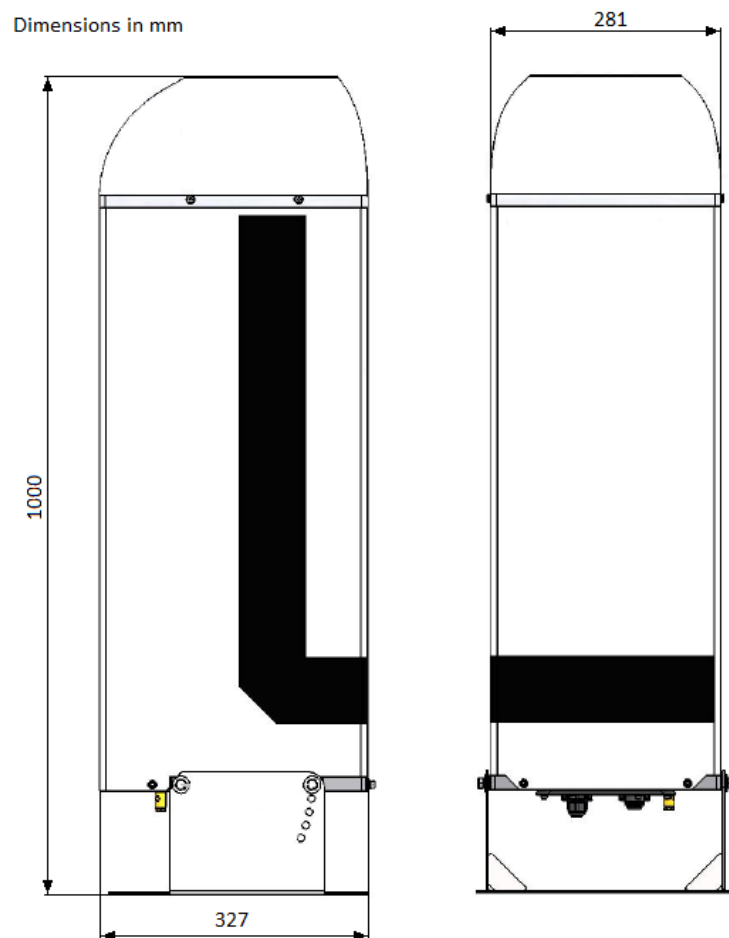

Fig 2.3 CS135 Dimensions

2.4.3 Electrical Specifications

Power required: Nominal 115 (106-137) or nominal 230 (216-253) VAC, 47-63 Hz, 470 W maximum in total.

The hood heater requires a maximum of 270 W.

The internal heater requires a maximum of 120 W.

The supply voltage required is specified at the time of order.

Fuses: The fuse should be HBC SA(T). Older units contained:

AUX fuse HBC 5 A (T)

PSU fuse HBC 500 mA (T)

CAUTION

The fuse values used must match the design of power supply unit.

All fuses are 5 x 20 mm slow blow (T) and are the same for both 115 VAC and 230 VAC.

Battery: Internal 12V 2Ah sealed lead-acid battery provides 2hr measurement without the blower/heater. The power supply is equipped with a system to prevent deep discharge of the battery.

The CS135 uses Positive Temperature Coefficient (PTC) heaters within its design. These heaters are self-regulating, simplifying the internal design of the sensor and improving safety. Due to the nature of these devices the CS135 takes a higher current during start up.

The CS135 will take up to 1 KW for the first few seconds of operation dropping off quickly to its normal operating power over a period of a minute.

In cold environments the power consumption of the CS135 may be as high as 470 W. Also, in warmer environments it may be as low as 200 W.

The heaters within the CS135 are purely resistive which will prove advantageous when connected to generators or when the power factor of your supply is important.

Older PSU design

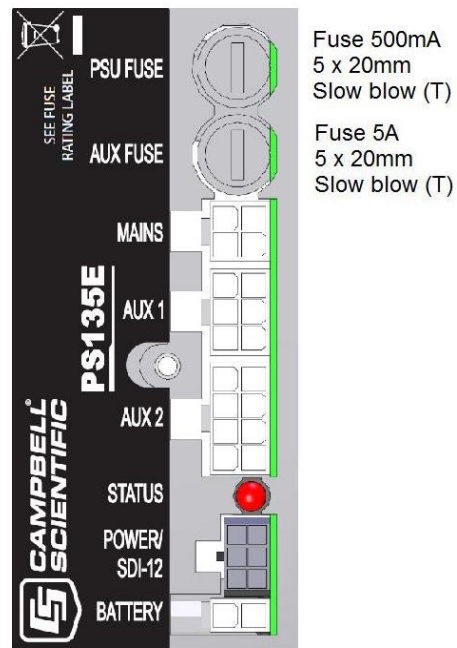

New PSU design

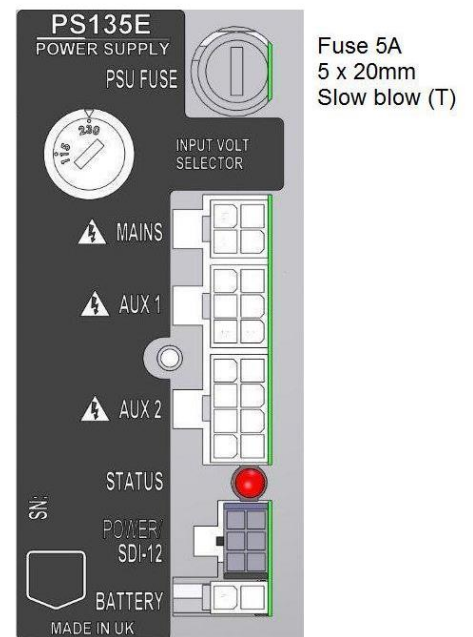

Fig 2.4 PSU types

2.4.4 Optical Specifications

- Pulse duration: 100 ns
- Pulse frequency 10 kHz
- Wavelength: 905 nm
- Half-angle laser divergence: 0.35 mrad
- Field of view: 1.5 mrad
- Laser lifetime: 10 years typical
- Eye safety class: 1M

2.4.5 Environmental Specifications

Standard Operating Temperature Range: -40°C to +60°C (Excluding battery, battery temperature range: -20°C to +50°C. Alternative battery types available).

Relative Humidity Range: 0 to 100%

IP Rating: IP 66

2.4.6 Communications Specifications

Supported serial settings

8 bits, no parity, 1 stop bit (default)

7 bits, even parity, 1 stop bit

7 bits, odd parity, 1 stop bit

Supported data rates

300 bps

600 baud

1200 baud

2400 baud

4800 baud

9600 baud

19200 baud

38400 baud

57600 baud

76800 baud

115200 baud (default)

Supported standards

RS232 full duplex (default)

RS232 half duplex

RS485 full duplex

RS485 half duplex

Signal voltage levels

	Minimum Value	Nominal Value	Maximum Value
RS232 Communications			
RS232 input threshold Low	0.8V	1.5V	-
RS232 input threshold High	-	2.0V	2.4V
RS232 input absolute maximum	-15V	-	+15V
RS232 input resistance	12K Ω	-	-
RS232 output voltage low	-	-	0.4V
RS232 output voltage high (into 3K Ω)	4.4V	-	-

RS485/422 Communications			
RS485/422 input threshold voltage	-0.2V	-	+0.2V
RS485/422 output (Unloaded)	-	-	5V
RS485/422 output (Load 50 Ω)	2V	-	-
Maximum voltage at any terminal	-7V	-	+7V

USB Service Port USB1.1 and 2.0 compatible, fixed 115200 baud.

3. Initial preparation and checks

The following steps will provide basic familiarisation with the CS135 and perform basic functionality checks. To do these you must first remove the cover and enclosure lid (see Sections 4.6.1 and 4.6.2) and then connect the battery (see Section 4.6). Connect the hood heater plug once you have done these stages. See Fig 4.3 in Section 4.5.1.

WARNING

The laser will be operating as soon as the battery is connected. It should not point in any direction where it could be viewed with magnifying optics.

The green LED visible from above should now be flashing once every 10 seconds (see Fig 5.2).

Connect a PC using a terminal emulation program to the USB port (Fig 4.5). The terminal emulator should be set to 115200 baud, 8N1 bits/parity.

PC operating systems should identify the USB connection and allocate a port number. The terminal emulator program you are using should then be set to this port number. Older PC operating systems may need upgrading or additional software.

The CS135 will be outputting message type 001 every 10 seconds (see Section 6.2).

Open terminal mode with the command "open 0". You should now see the prompt "CS135>", Type "Status". You will now see the sensor status information described in Section 5.1.5. If you plan to use date/time information this should be checked as it can drift up to ± 14 seconds per day.

If the unit has been in storage or transit for more than a few months, the clock battery may be discharged. However, it will charge from the back-up battery or mains power.

Close terminal mode with the command “close” (it will close automatically after 10 minutes of inactivity).

If you are not installing the unit straight away you should disconnect the battery to avoid it being discharged.

4. Installation

4.1 Location and Orientation

The CS135 measures environmental variables and is designed to be located in harsh weather conditions. However there are a few considerations to take into account if accurate and representative data from a site are to be obtained.

In order to reduce the service frequency with the unit, the CS135 should be placed away from sources of contamination. More regular maintenance will be required when the instrument is placed in areas where contamination is unavoidable or where measurements may be safety related.

Take care that the orientation allows tilting in whatever direction is desired.

WARNING

If installing at an airport check and follow local guidance for allowed locations for a non-frangible object 1m tall. Please contact Campbell Scientific if frangible fittings are required.

4.2 Grounding

The CS135 must be properly grounded by taking a ground wire with a minimum cross sectional area of 16 mm^2 and maximum length of 10 m from the brass grounding boss to an adequate grounding point. Figure 4.3 shows the location of the grounding boss.

4.3 Mounting the CS135

The CS135 is designed to be bolted to a firm, level foundation. When bolting down take care that the orientation allows tilting in whatever direction is desired.

Fig 4.1 shows the mounting footprint.

If a suitable surface does not already exist then a concrete foundation should be constructed at least 600 mm square and 600 mm deep.

Drill four 12 mm diameter holes using the mount base as a template to a depth of 77 mm.

Clean the holes of all debris.

Place washers and nuts on the ends of the wedge anchors supplied (to protect the threads during installation).

Hammer the wedge anchors into the holes until the start of the threads are below the surface.

Tighten the nuts until about 25 mm of thread protrudes above the surface.

Remove the washers and nuts from the protruding length screw. Then lower the CS135 into place.

Finally, secure the CS135 with the washers and nuts.

If the surface is not level and flat it may be necessary to add washers under the base on one or more of the foundation screws.

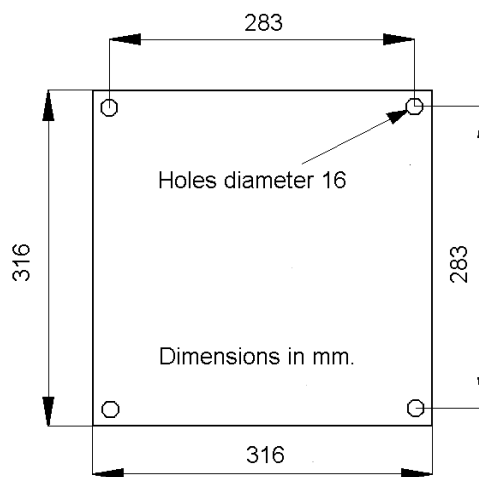

Fig 4.1 Mounting footprint

4.4 Tilt Angle

The CS135 is designed to be tilted 6°, 12°, 18° or 24° from vertical. There are several reasons why this might be done. In tropical regions it might be advantageous to tilt the sensor north in the northern hemisphere and south in the southern hemisphere to prevent the sun shining directly into it, it can reduce problems caused by direct specular reflections from ice crystals and reduce problems from rain or snow falling onto the window. To adjust the tilt angle remove the bolts shown in Fig 4.2, move the CS135 to the required tilt angle and replace them.

The CS135 has tilt sensors in both axes so that if it is not possible to provide a level base cloud height can be compensated. Cloud height compensation can be set or disabled using the UNITS command (see Section 5.1.3). This feature can be useful for mobile or marine applications. Note that profile data is NOT compensated but tilt angles are included in data messages.

Note that increasing the tilt angle beyond 24° can cause significant errors in vertical visibility measurements if scatter coefficients vary significantly with height.



Fig 4.2 Setting the Tilt Angle

4.5 Connectors and wiring

4.5.1 Base connectors

The CS135 has three connectors on its base. One is for communications, one provides power input to the unit itself and the other one takes power from the unit to the hood heater and blower.

NOTE Tilting the unit will provide better access to these connectors.

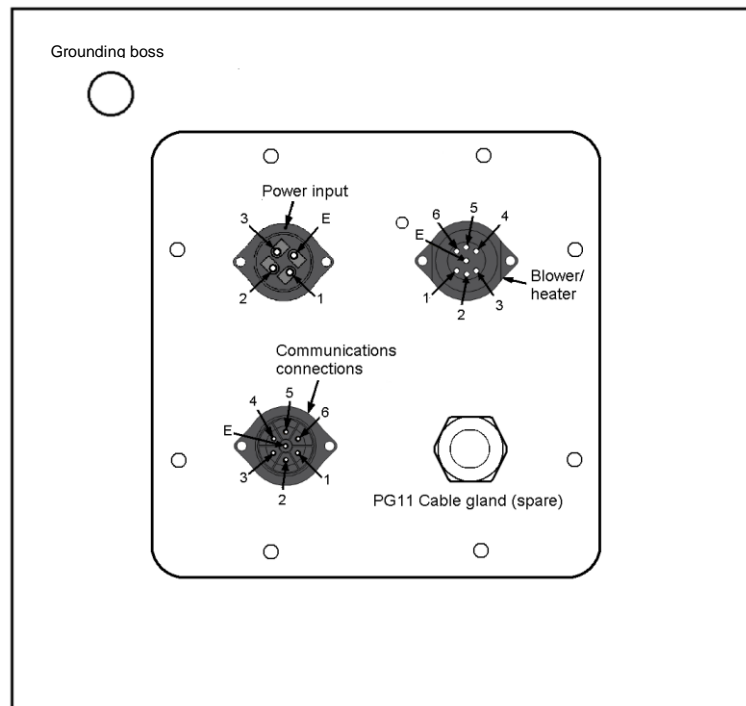

Fig 4.3 Connector Layout

The function of the connector pins is shown in Table 4.1.

Table 4.1 Function of the connector pins

Mains Connector

Pin	Function	Colour of supplied cable cores
1	Live	Brown
2	Not connected	NA
3	Neutral	Blue
4	Earth	Green/yellow

Blower/Heater Connector

Pin	Function	Colour of supplied cable cores
1	Neutral	Black (1)
2	Fan + 12V	Black (2)
3	Therm	Black (3)
4	Therm (0V)	Black (4)
5	Switched 230/115 AC Live	Black (5)
6	Fan on	Black (6)
E	Earth	Green/yellow

Communications Connector

Pin on connector on CS135	Colour of supplied cable cores	9-PIN 'D' Connector (Fig 4.4)	RS232	RS485 Half duplex	RS485 Full duplex/RS422
1	Red	8	CTS*	Y	Y/T _x non-inverting
2	Yellow	7	RTS*		B/R _x non-inverting
3	Green	5	Gnd		
4	Black			Gnd	Gnd
5	White	2	Tx	Z	Z/T _x inverting
6	Blue	3	Rx		A/R _x non-inverting
E	Screen				

*If hardware handshaking is not used pins 7 and 8 should be connected together.

4.5.2 Wiring Using Supplied Campbell Scientific Cables

Two cables are supplied, each 10 m long. One is for the mains power supply, the other is for communications.

WARNING

If the power cable is incorrectly wired then irrevocable damage can be done to the unit and there is risk of serious injury or death.

WARNING

The power cable must not be carrying mains voltage when it is being connected or disconnected.

4.5.2.1 Power Connections

The following guidance is given to help the wiring and installation of a permanent power supply to the sensor.

As the sensor is used outside, the installation of the power cables will normally have to be carried out by a qualified electrician. Please check local safety regulations.

A mains power source needs to be identified and the type of termination, cable type and cable run matched to comply with local regulations and the type of installation.

The power source needs to be able to provide the correct voltage and frequency and current in excess of the power requirement of the system. See below.

Voltage requirements: 106-137V or 216-253V AC (check power supply switch and fuses match the nominal 115/230V supply)

Current requirements: 5A

Input frequency: 47-63 Hz.

The power source needs to be fused. The fuse rating should be 5A or larger and a “slow blow” design. Any extensions to the cable supplied or alternative replacement should be capable of carrying current in excess of that fuse rating.

The power source should be fitted with a two-pole isolator and should be fitted as near to the sensor as is possible.

The power cable needs to have three conductors, live, neutral and a protective earth, normally with IEC wiring colours to match those used.

This equipment requires a protective earth. **THIS MUST BE CONNECTED FOR SAFETY REASONS.** Ensure the earth connection at the power source is suitable for this purpose. The connection should be made via the earth wire of the power connector/cable or via the earth stud on the sensor base.

This equipment also requires correct connection of the live and neutral conductors – make sure these are identified and wired correctly at the power source.

Normally, the power source should be fitted with its own or system wide earth leakage breaker (also known as an RCD).

For short term testing of the sensor a suitable plug can be fitted to the end of the power cable and the sensor plugged into a standard mains supply capable of providing 5A at the rated voltage. If this is done the earth wire of the sensor must be connected to a suitable protective earth point.

4.5.2.2 Communications connections

The communications cable is terminated at one end with a removable 9 pin D-connector (DB9). The D-connector can be connected directly to a PC or data logger such as the Campbell Scientific CR1000 using a suitable interconnecting cable such as the SC110. Connections and wire colours are shown in Fig 4.4. The connector can easily be removed for direct connection to screws terminals.

If hardware handshaking is not to be used then pins 7 and 8 should be connected together.

CAUTION

The type of cable supplied is not recommended for lengths greater than 10 m. In particular, longer length RS485 cables should incorporate twisted pairs. Please contact Campbell Scientific if you wish to use a longer length of cable.

CS135 COMMS CABLE CONNECTOR

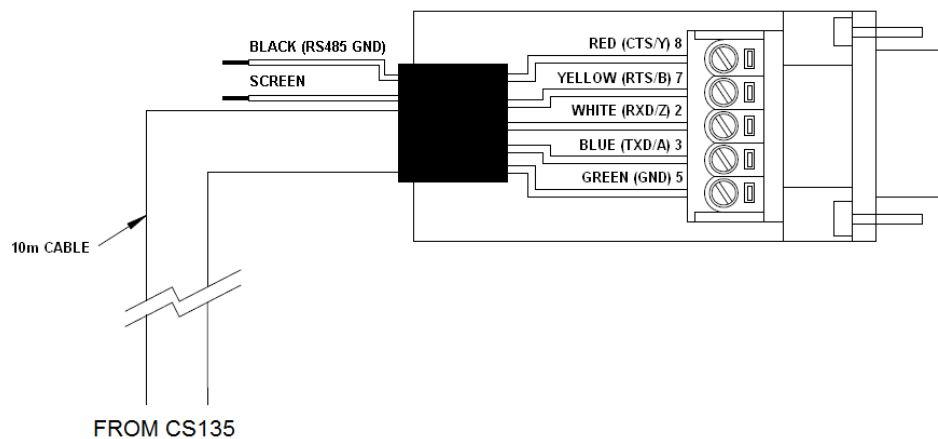

Fig 4.4 Cable Connections

Tilting the unit, see Fig 4.2 will make wiring easier.

4.5.3 USB Connection

A USB port is provided inside the enclosure to aid on-site maintenance. This allows communication of commands to the CS135 and responses in the same form as the main serial port except that the baud rate is fixed at 115200 (see Fig 4.5).

4.5.4 SDI-12 Connection

A SDI-12 port is present but is only used for factory setting of the instrument.

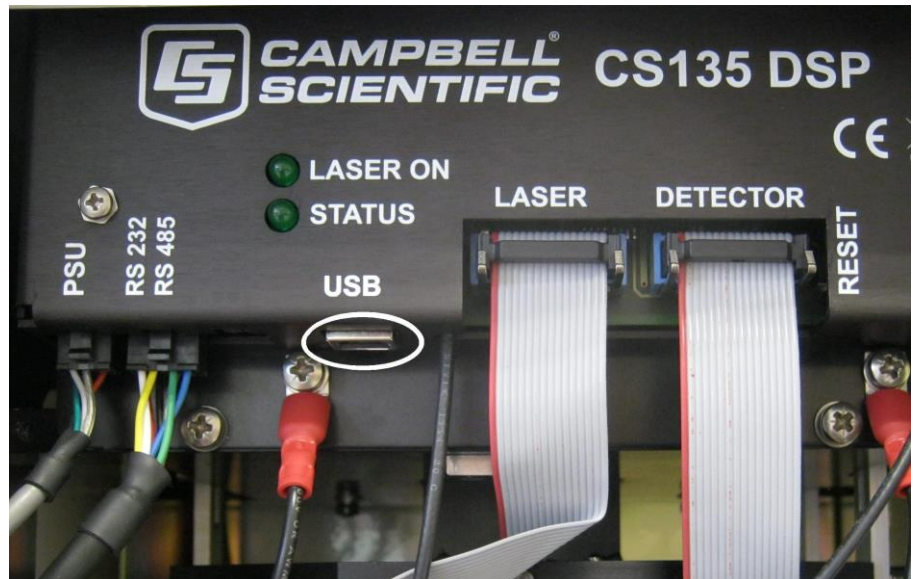

Fig 4.5 USB port

4.6 Connecting the Back-up Battery

The CS135 will be shipped with the back-up battery disconnected. It should be connected as shown in Fig 4.6 before bringing the unit into use.

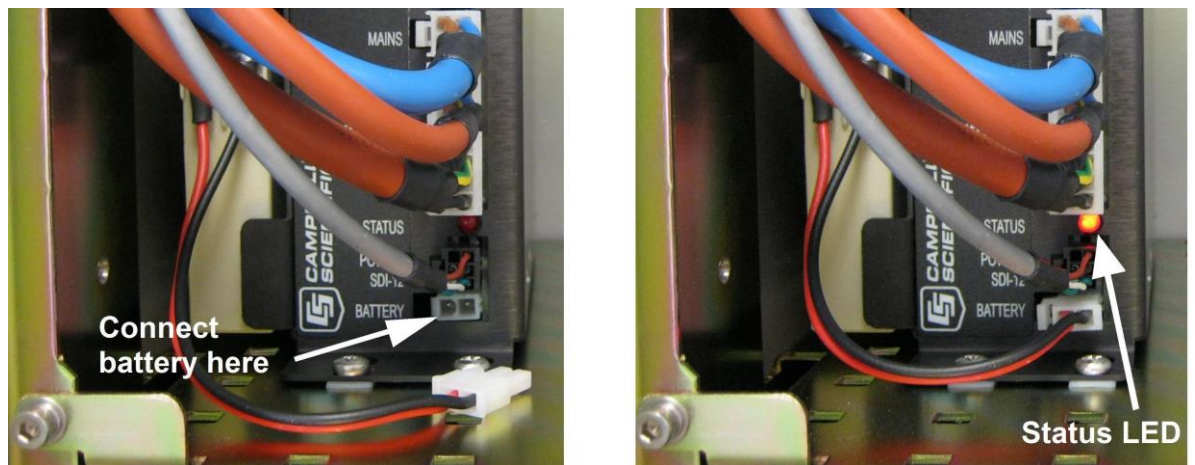

Fig 4.6 Connecting Battery

To do this the cover and enclosure lid must first be removed. The desiccant included for transport should be removed at the same time.

4.6.1 Removing the Cover

The cover is removed by removing the four screws as shown in Fig 4.7.

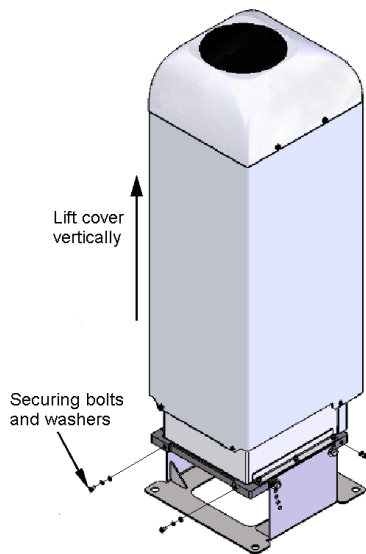

Fig 4.7 Removing the Cover

The cover can then be lifted away.

CAUTION

The cover contains a flying lead used to take power to the hood heater and blower. Be careful not to trap and damage this when lifting the cover clear.

4.6.2 Removing the Enclosure Lid

Removing the lid covering the electronics unit is accomplished by removing the four screws as shown in Fig 4.8.

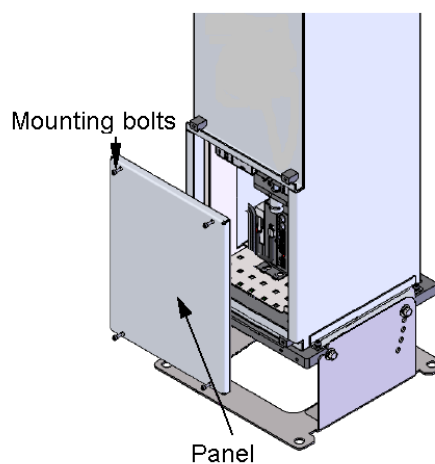

Fig 4.8 Removing the Enclosure Lid

WARNING Opening the access door **MUST** be carried out by a competent person

WARNING Removing the enclosure lid may expose hot surfaces

4.7 Bird Spike Kit

A bird spike kit, available as a special, deters birds from sitting on the CS135. This comprises 4 stainless 'spikes' with rounded ends and a small reel of stainless wire. Fig 4.9 shows installed bird spikes.

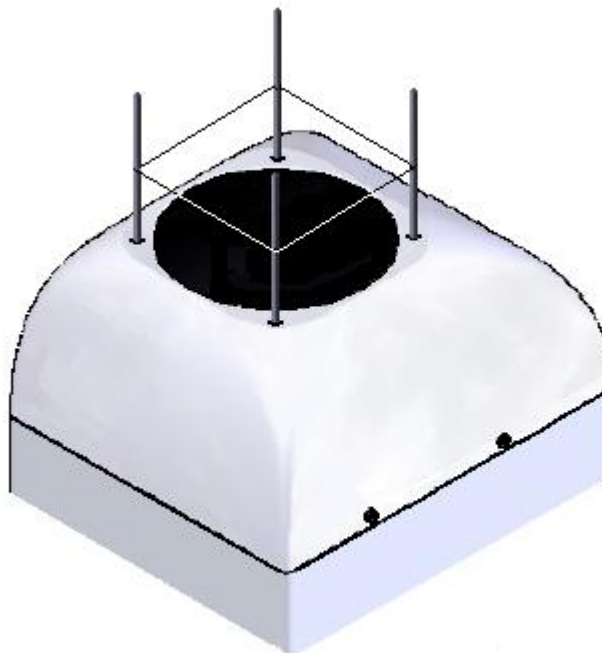

Fig 4.9 CS135 Bird Spike Kit installed

To install the bird spikes first remove the cowl and blanking plugs from the cowl as shown in Fig 4.10. If the CS135 is an older unit without pre-existing holes then it will be necessary to drill 4 holes each 4.5 mm diameter, evenly spaced around the aperture and 10 mm in from the edge. Each spike is then inserted into the holes, thread first, and nuts and washers attached and tightened, see Fig 4.11. Then replace the cowl on the CS135.

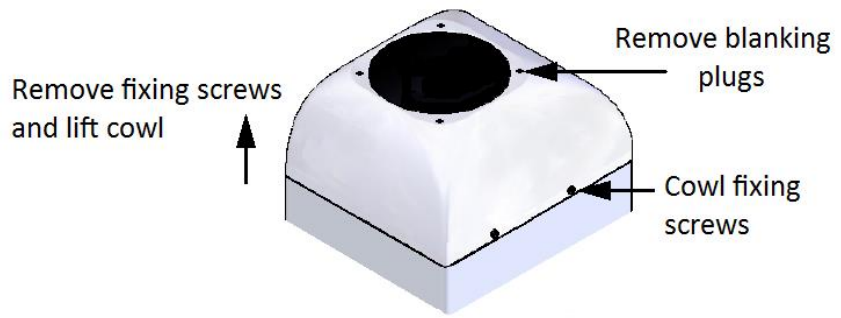

Fig 4.10 Preparing the CS135 for Installing the Bird Spikes

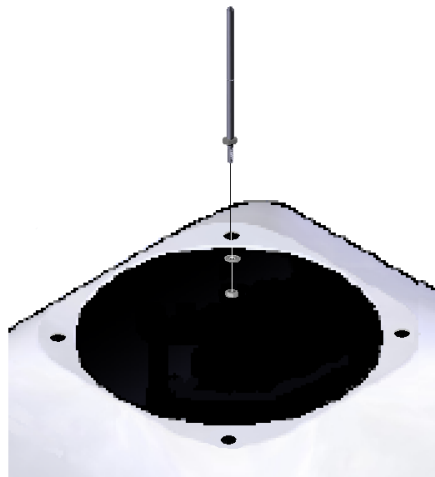

Fig 4.11 Attaching Bird Spikes to the CS135 cowl

Finally wrap stainless steel wire around the spikes using the grooves in the spikes. The wire is easily wrapped around each spike in turn and then back on itself. Do not tighten the wire too much as it may pull the spikes inwards and obscure the field of view of the CS135 optics.

Only use one strand of wire to reduce the possibility of water drops being collected.

Check the wire during maintenance and replace if necessary.

4.8 Storage Information

The CS135 should be stored between -40°C to $+70^{\circ}\text{C}$ in a dry place, preferably with the enclosures securely fastened. The optics should be protected from possible accidental damage. For storage the back-up battery should be disconnected.

NOTE

Leaving the battery connected during storage will mean that the unit will still be powered until the battery voltage falls below a shut-down threshold.

NOTE If the CS135 has been stored below 0.0°C the start-up time will progressively take longer - up to 10 minutes. Full accuracy will not be achieved for an hour at -20°C.

NOTE The battery has a temperature range of -20°C to +50°C and should be removed if the CS135 is to be stored outside this range.

5. Operation

5.1 Terminal mode

5.1.1 Entering/Exiting the CS135 Terminal Mode

The menu system is entered with the command `OPEN Sensor_ID Password` (The menu will time out & close automatically if not used for 10 minutes).

Sensor_ID is the CS135 identification, a single ASCII character 0-9,a-f,A-F case sensitive. The default is 0. If a password is set then it must be entered here otherwise it can be omitted. The following text should now be displayed: "CS135>". The CS135 is now ready for terminal mode commands.

The CS135 Commands are not case sensitive. The Parameters and/or password following the command are case sensitive.

Example of the "open" command followed by the parameter "0":

```
OPEN 0
```

Example of the open command with the password "Secret":

```
OPEN 0 Secret
```

5.1.2 Terminal Mode Commands General

Table 5.1 gives a summary of the terminal mode commands available.

The CS135 can be setup and controlled by using the terminal interface where discrete commands are sent. The terminal commands can be sent via a logger to the CS135 removing the need for a local PC to set up the unit.

The terminal emulators built into many Campbell Scientific software products can also be used. Note however that DevConfig and PW Viewer cannot be used to load a new operating system as this requires XMODEM protocol. One common, freely available terminal emulator with this feature is called “TeraTerm” which is easily available on the internet.

The following settings are used:

<u>RS232/422/485 interface (default)</u>	<u>USB service port</u>
RS232 Full Duplex	Baud: rate 115200
Baud rate: 115200	Data bits: 8
Data bits: 8	Parity: none
Parity: none	Stop bits: 1
Stop bits: 1	Flow control: none
Flow control: none	

Ensure that if the baud rate of the unit has been adjusted and then the corresponding bits per second value are entered in the port settings of the terminal emulator. The CS135 should now be ready to accept commands.

Note: commands will always output all parameters on a new line after a *CR LF* & then the CS135 prompt ‘CS135>’. If you only want to see parameter values without changing them then enter the command without parameters. If a particular parameter did not need changing then the parameter can be replaced with a comma (,). Back space will abort the command.

5.1.3 Terminal mode command examples

The following text shows an example of setting up the CS135 serial port. This example would set the serial port to RS232 full duplex at 115200bps, 8 data bits, no parity and if it was in RS485 mode then a 100mS turn around delay.

```
serial 0 10 0 100
```

You could also type the following to obtain the same results as the RS485 turn around delay is not needed:

```
serial 0 10 0
```

If all you wish to do is change the data baud rate and nothing else you can replace the first number, the mode parameter, with a ‘,’ as shown below.

```
serial , 10
```

Alternatively if you just wished to change the parity to 8-bits no parity then type the following:

```
serial , , 0
```

You do not need to replace the remaining parameters with ‘,’ you only need to replace the ones up to the parameter you wish to edit.

NOTE

Remember to leave a space character between the command and the parameters as shown in the examples.

Table 5.1 Summary of the terminal mode commands available

Command	Parameter/ Parameter block	Description
ALARMS	<i>Angle</i>	<i>Angle</i> is the threshold tilt angle of the sensor beyond which an alarm will be flagged. The settable range is 0 to 90.0 degrees tilt and the default is 45.0 degrees.
BS	<i>Attenuated_SCALE</i> , <i>BS_Av_Time</i> , <i>Noise_Gate</i> , <i>Measurement_Period</i> , <i>Rolling_Average</i> , <i>Message_Interval</i>	<p>Rules for BS command are: <i>BS_Av_Time</i> <= <i>Measurement_Interval</i>-1. <i>Message_Interval</i> must be a multiple of <i>Measurement_Period</i>.</p> <p><i>Attenuated_SCALE</i> is the scalar for the attenuated backscatter %. 0.001 to 1000 (default 100%)</p> <p><i>BS-Av_Time</i> is the backscatter average time in seconds. 1 to 30 (default 2). Note: Must not be greater than <i>Measurement_Period</i>-1.0</p> <p><i>Noise_Gate</i> controls the noise threshold applied to back-scatter. <i>Noise_Gate</i> = -1000, all backscatter range is corrected. <i>Noise_Gate</i> = 0.0-1000.0, standard deviation for noise threshold, default 2.0. Only backscatter above this is range corrected.</p> <p><i>Measurement_Period</i> 0 or 2 to 600 (default 10). If set to 0 and the CS135 is polled it will output the last measurement made. If it is between 2 and 600 seconds then the CS135 will continually output messages. For sky condition output it is recommended that the <i>measurement_Period</i> is set no longer than 30 seconds. If a <i>measurement_Period</i> greater than 30 seconds is used then the sky condition algorithm will be less able to resolve coverage for higher order layers. Note: Must be a sub multiple of <i>Message_Interval</i></p> <p><i>Rolling_Average</i> = 1 to 29 default 1. This is the number of <i>measurement_periods</i> to use in a rolling average of the backscatter.</p> <p><i>Message_Interval</i> is the message interval in seconds, 2 - 600 seconds. '0' gives polled messages, default 10. Note: Must be a multiple of <i>Measurement_Period</i></p>
CLOSE	<i>No parameters</i>	Closes the terminal interface to allow normal message output and saves new settings to flash non-volatile storage.
DEFAULTS	<i>No parameters</i>	Loads factory defaults
GETUSER		<p>Reads all user settings as a string of text. Parameters are read in the following order:</p> <p><i>user</i> = text "user" <i>volVer</i> = user volume version <i>OS_VER</i> = DSP OS version <i>PsuOsVer</i> = PSU OS version <i>TopOsVer</i> = TOP OS version <i>Id</i> = CS135 ID <i>Pw</i> = CS135 password <i>terminalCrc</i> = terminal crc mode <i>terminalTimeout</i> = terminal timeout <i>unitsTiltMode</i> = units and tilt mode <i>hoodHBMode</i> = hood heater / fan heater mode <i>hoodHBTestInt</i> = hood heater / blower test interval in hours <i>battBoost_mV</i> = boost voltage used for battery charging mV</p>

	<p> <i>battCharge_mA</i> = battery charge current mA <i>psuPresent</i> = PSU present switch <i>hoodHBNormSpeed</i> = Fan voltage for normal speed mV <i>hoodHBHighSpeed</i> = Fan voltage for high speed mV <i>hoodHBLowSpeed</i> = Fan voltage for low speed mV <i>intHMode</i> = internal heater mode <i>message[0]</i> = fields for message 0 <i>message[1]</i> = fields for message 1 <i>message[2]</i> = fields for message 2 <i>message[3]</i> = fields for message 3 <i>message[4]</i> = fields for message 4 <i>messagePeriod</i> = output message period in seconds <i>heightOffset</i> = height offset metres <i>bsAvTime</i> = backscatter average time in seconds <i>laserMode</i> = laser operation mode <i>laserPower</i> = laser power <i>laserHeater</i> = laser heater mode <i>attenuatedSCALE</i> = attenuated backscatter scaling factor <i>logInterval</i> = debug logging interval <i>measurementPeriod</i> = measurement interval in seconds <i>serMode</i> = serial port mode <i>baudSel</i> = serial port baud rate mode <i>dataParityStop</i> = serial port parity mode <i>rx2txTimeout</i> = serial port RX to TX turnaround time <i>snrMarginBoundary</i> = onset of backscatter detection threshold <i>snrMarginDetector</i> = cloud detection threshold <i>alphaGuessEnd</i> = cloud alpha guess at boundary <i>alphaMin</i> = cloud detection alpha minimum <i>Vcld_D</i> = cloud detection <i>delat_Vcld_D</i> = cloud detection <i>vis_Av_T</i> = cloud detection <i>alphaGuess</i> = visibility initial alpha guess <i>ratioLevel</i> = visibility ratio <i>alphaMin</i> = visibility alpha minimum <i>cap</i> = visibility cap in metres <i>tiltLimit</i> = tilt limit in degrees used by alarms <i>noiseGate</i> = attenuated backscatter noise gate mode <i>vvLimit_percent</i> = sky condition report vertical visibility % <i>alphaGuessStart</i> = cloud detection alpha guess at lowest height bin <i>dt</i> = mixing layer height temporal filter minutes <i>dr</i> = mixing layer height range filter metres <i>q1threshold</i> = mixing layer height quality threshold 1 <i>q2threshold</i> = mixing layer height quality threshold 2 <i>q3threshold</i> = mixing layer height quality threshold 3 <i>stdWidth</i> = mixing layer height standard deviation width metres <i>CRC</i> = 4 digit ASCII hex CRC calculated from the 'u' of user up-to but not including the CRC using the standard CRC16-CCITT. </p> <p>Note: Many of these parameters may not have been adjusted. This command allows a reliable technique for copying full settings from one CS135 to another with the 'SETUSER' command.</p> <p>A typical response to the GETUSER command is:</p> <pre> >>>>>>>>> COPY FROM START OF NEXT LINE >>>>>>>>> user 7 007638-6da 106 510 0 , 0 10 2 0 1 14520 400 1 1000 1000 2000 0 1 0 0 0 0 10 0.000E+00 2.000E+00 1 1.000E+00 0 1.000E+00 0 10 1 0 </pre>
--	---

		<p>10 0 100 4.000E+00 6.000E+00 2.000E-03 2.500E-04 1.000E+03 2.200E+01 4.800E+03 1.000E-01 9.000E-01 2.500E-04 2.000E+03 4.500E+01 2.000E+00 50 2.00E-03 3.000E+01 1.500E+02 1.800E+00 5.000E+00 1.000E+01 150 98b2</p> <p><<<<<<<<<< TO START OF THIS LINE <<<<<<<<<<</p>
HEATERS	<i>Hood, Internal, Laser, Test_interval,</i>	<p>Sets or reads heater settings as follows:</p> <p><i>Hood</i> = 0, Hood blower and heater OFF <i>Hood</i> = 1, Hood blower ON and heater OFF <i>Hood</i> = 2, Hood blower ON and heater ON <i>Hood</i> = 3, Hood blower and heater AUTO (default) – (See note (1) below.</p> <p><i>Internal</i> = 0, Internal heater OFF <i>Internal</i> = 1, Internal heater ON <i>Internal</i> = 2, Internal heater AUTO (default)</p> <p><i>Laser</i> = 0, laser heater off <i>Laser</i> = 1, laser heater on (default)</p> <p><i>Test_interval</i> = 1-168 hours (default 24h). Heater/Blower test interval</p>
HELP	<i>No parameters</i>	Calls up a list of user commands with brief descriptions
HOFFSET	<i>Height_offset</i>	<i>Height_offset</i> is the offset to be added or subtracted in the range -1000 m to +1000 m or -3281 ft to +3281 ft. Positive values are added to measured height and negative values are subtracted from measured height. The default is 0.
ID	<i>Sensor_ID</i>	Reads or sets the sensor ID, a single ASCII character, 0-9, a - z or A - Z, case sensitive. Default ID = 0. Note that if a CT25K message is to be used lower case letters are not allowed.
LASER	<i>Laser, Laser_Power</i>	<p><i>Laser</i> = 0, Laser off after power up (user must switch laser on). <i>Laser</i> = 1, Laser on after power up (default).</p> <p><i>Laser_Power</i> = 20%-100%, default 100%.</p>
LASEROFF	<i>No parameters</i>	Instructs the CS135 to turn the laser off until either a power cycle or the sensor is instructed to turn the laser back on.
LASERON	<i>No parameters</i>	Instructs the CS135 to try and turn the laser on
LOADOS	<i>Module</i>	<p>Loads new operating system into modules as follows: <i>Module</i> =1, DSP.</p> <p>Note: Operating systems earlier than 4 will need the boot loader updating. Refer to Section 5.1.8 for more information.</p> <p><i>Module</i> =2, TOP</p> <p><i>Module</i> =3, PSU</p> <p><i>Module</i> =4, DSP, TOP & PSU as one file. This is only supported from Operating system 8</p> <p>This command must be sent using XMODEM protocol. Refer to Section 5.1.8 for more information.</p>

MCFG	<i>Message_Interval,</i> <i>Message_ID_A,</i> <i>Message_ID_B,</i> <i>Message_ID_C,</i> <i>Message_ID_D,</i> <i>Message_ID_E</i>	Set or read message configuration. <i>Message_Interval</i> is the message interval in seconds, 2 to 10 or 20 to 600 in steps of 10. 0 gives polled messages, default 10. Note: This command may affect measurement parameters within the ‘BS’ command. Similarly changes within the ‘BS’ Command can allow other message intervals and measurement periods. See Section 5.1.5 <i>Message_ID</i> is the message type to output between 0 and 999 (default 001). If <i>Message_ID</i> = 0 no message type will be output. Up to 5 messages can be set. Please refer to Section 5.1.4.
MLH (if available)	<i>Temporal_Filter,</i> <i>Range_Filter,</i> <i>Std_Width,</i> <i>Q1_Threshold,</i> <i>Q2_Threshold,</i> <i>Q3_Threshold,</i>	<i>Sets or reads parameters used in identifying Mixing Layer heights</i> <i>Temporal_Filter</i> = temporal filter used to filter data used by mixing layer height algorithm in minutes. 1 to 40 (default 30 minutes) <i>Range_Filter</i> = range filter half width used to smooth data used by mixing layer height algorithm in metres or feet. 15 m to 600 m or 49 ft to 1969 ft (default 150 m or 492 ft) <i>Std_Width</i> = range half width used to calculate standard deviation of the noise in metres or feet. 10 m to 400 m or 33 ft to 1312 ft (default 150 m or 492 ft) <i>Q1_Threshold</i> = SNR threshold for quality level 1 mixing layer height output. 1.0 to 30.0 (default 1.8) <i>Q2_Threshold</i> = SNR threshold for quality level 2 mixing layer height output. 1.0 to 30.0 (default 5.0) <i>Q3_Threshold</i> = SNR threshold for quality level 2 mixing layer height output. 1.0 to 30.0 (default 10.0)
OPEN	<i>ID,</i> <i>Password</i>	Opens the CS135 terminal mode. <i>ID</i> = Sensor ID as per the terminal command “ID” <i>Password</i> = The sensors user password as per the terminal command “PASSWORD”. The default is no password.
PASSWORD	<i>Password</i>	Sets or clears a password from 1 to 10 characters in length. Valid ASCII characters 0-9, a - z or A – Z and letters are case sensitive. Typing the command PASSWORD without any parameters clears the password. The default is no password.
POLL	<i>Sensor_ID</i> <i>Message_ID</i>	Requests the message <i>Message_ID</i> from the sensor <i>Sensor_ID</i> . Refer to the Section 5.1.6 for more information on this command Note: If <i>Message_ID</i> is omitted the CS135 outputs the message configured by MCFG.
POWEROFF	<i>No parameters</i>	This will prepare the PSU to power down the CS135 even if the battery is connected. As soon as the mains supply is disconnected the CS135 will power off and NOT run on battery back-up. The CS135 can be re-activated with battery back-up enabled by re-connecting the mains supply. You will be asked to confirm.
REBOOT	<i>No parameters</i>	Forces a system reboot. This will restore previously saved user settings. Any unsaved changes will be lost. (Settings are saved in terminal mode when the command CLOSE is typed, which exits the terminal mode).
SCCAL	<i>No parameters but user interaction required</i>	Stratocumulus backscatter calibration. This requires a human observer to confirm a stable Stratocumulus cloud layer between 250 m to 2500 m without holes, precipitation or reduced visibility and has been stable for at least 10 minutes prior to running this command. See Section 5.1.9 for more information.

SERIAL	<i>Mode, Baud, Bits_Parity, Delay</i>	<p>Set or read the serial port</p> <p><i>Mode</i> = 0, RS232, full duplex (default). <i>Mode</i> = 1, RS232, half duplex. <i>Mode</i> = 2, RS485, full duplex. <i>Mode</i> = 3, RS485, half duplex. <i>Mode</i> = 4, Reserved. <i>Mode</i> = 5, RS422, full duplex.</p> <p><i>Baud</i> = 0, 300 baud. <i>Baud</i> = 1, 600 baud. <i>Baud</i> = 2, 1200 baud. <i>Baud</i> = 3, 2400 baud. <i>Baud</i> = 4, 4800 baud. <i>Baud</i> = 5, 9600 baud. <i>Baud</i> = 6, 19200 baud. <i>Baud</i> = 7, 38400 baud. <i>Baud</i> = 8, 57600 baud. <i>Baud</i> = 9, 76800 baud. <i>Baud</i> = 10, 115200 baud (default).</p> <p><i>Bits_Parity</i> = 0, 8 bits, no parity, 1 stop bit (default). <i>Bits_Parity</i> = 1, 7 bits, even parity, 1 stop bit. <i>Bits_Parity</i> = 2, 7 bits, odd parity, 1 stop bit.</p> <p><i>Delay</i> is the delay time in mS to TX (RS485 half-duplex mode only). Range 0-100 mS, default 100 mS.</p>
SERVICE	<i>No parameters but user intervention required</i>	Performs a service procedure
SETUSER	<i>String</i>	<p>Load all user settings as a string of text. (not changed) = parameter will not be updated and the previously set value will persist.</p> <p>String = user (not changed) volVer = user volume version (not changed) OS_VER = DSP OS version (not changed) PsuOsVer = PSU OS version (not changed) TopOsVer = TOP OS version (not changed) Id = CS135 ID (not changed) Pw = CS135 password (not changed) terminalCrc = terminal crc mode terminalTimeout = terminal timeout unitsTiltMode = units and tilt mode hoodHBMode = hood heater / fan heater mode hoodHBTestInt = hood heater / blower test interval in hours battBoost_mV = boost voltage used for battery charging mV battCharge_mA = battery charge current mA psuPresent = PSU present switch hoodHBNormSpeed = Fan voltage for normal speed mV hoodHBHighSpeed = Fan voltage for high speed mV hoodHBLowSpeed = Fan voltage for low speed mV intHMode = internal heater mode message[0] = fields for message 0 message[1] = fields for message 1 message[2] = fields for message 2 message[3] = fields for message 3 message[4] = fields for message 4 messagePeriod = output message period in seconds</p>

		<p>heightOffset = height offset metres bsAvTime = backscatter average time in seconds laserMode = laser operation mode laserPower = laser power laserHeater = laser heater mode attenuatedSCALE = attenuated backscatter scaling factor logInterval = debug logging interval measurementPeriod = measurement interval in seconds serMode = serial port mode baudSel = serial port baud rate mode dataParityStop = serial port parity mode rx2txTimeout = serial port RX to TX turnaround time snrMarginBoundary = onset of back-scatter detection threshold snrMarginDetector = cloud detection threshold alphaGuessEnd = cloud alpha guess at boundary alphaMin = cloud detection alpha minimum Vcld_D = cloud detection delat_Vcld_D = cloud detection vis_Av_T = cloud detection alphaGuess = visibility initial alpha guess ratioLevel = visibility ratio alphaMin = visibility alpha minimum cap = visibility cap in metres tiltLimit = tilt limit in degrees used by alarms noiseGate = attenuated backscatter noise gate mode vvLimit_percent = sky condition report vertical visibility % alphaGuessStart = cloud detection alpha guess at lowest height bin dt = mixing layer height temporal filter minutes dr = mixing layer height range filter metres q1threshold = mixing layer height quality threshold 1 q2threshold = mixing layer height quality threshold 2 q3threshold = mixing layer height quality threshold 3 stdWidth = mixing layer height standard deviation width metres CRC = 4 digit ASCII hex CRC calculated from the 'u' of user up-to but not including the CRC using the standard CRC16-CCITT. Note: String is added as text and should be added as a "cut and paste" from a stored file.</p>
STATUS	<i>No parameters</i>	<p>Outputs CS135, serial number, ID, DSP OS version, Time & Date, DSP version, TOP OS version, PSU OS version, watch dog counts, serial parameters, blower heater mode, internal heater mode, message parameters, tilt angle, units, temperature/humidity, temperatures, supply voltages, height offset, visibility cap, laser run days, window parameters, backscatter parameters, MLH parameters, features, alarms, warnings & status. Note: Refer to Section 5.1.6 for more information on this command</p>
TERMINAL	<i>Terminal, Timeout</i>	<p>Sets CRC16-CCITT checking and the user terminal time out. <i>Terminal</i> = 0, CRC16-CCITT off (default). <i>Terminal</i> = 1, CRC16-CCITT on (all terminal commands need a CRC. See Section 5.1.10 for details). <i>Timeout</i> is the delay in minutes from 1 to 15 where the terminal will automatically close if no characters are sent to the CS135. The default is 10 minutes.</p>

TIME	<i>Date_Time</i>	Date is in the format yyyy/mm/dd Time is in the format hh:mm:ss yyyy=year, mm=month, dd=day hh=hours, mm=minutes, ss=seconds (i.e. time 2013/05/25 10:00:00, would set the date and time to May 25th 2013 at 10:00:00) Note: The set time could drift by up to ± 14 seconds a day.
UNITS	<i>Units</i>	Sets measurement units and tilt correction. <i>Units</i> = 0, metres corrected by tilt. <i>Units</i> = 1, metres not corrected by tilt. <i>Units</i> = 2, feet corrected by tilt (default). <i>Units</i> = 3, feet not corrected by tilt.
UNLOCK	<i>Key</i>	<i>Key</i> = a 12 digit ASCII hex key provided by CSL to unlock pay-for features
VIS	<i>Cap</i>	<i>Cap</i> is the vertical visibility maximum range 100 to 10000 in metres or 328 to 32808 in feet (default 2000 m or 6561 ft).

Note (1)

If AUTO is set then the Heater / blower will activate at 80°C if (sky condition > 1 okta coverage) or (cloud height < 3 Km AND sky condition > 1 okta coverage) OR window Tx < 80% OR precipitation detected. When the event has passed the blower/heater will remain active at 80°C for a further 15 minutes before going into a fan-off state and heater temperature average of approximately 40°C ready to be activated again.

5.1.4 MCFG command message types

The MCFG commands “Message_ID_x” parameter defines the following output types. Refer to Section 6 for further information on message output types.

Message_ID_x type	Description
000	No message
001 (default)	Campbell Scientific Message 1, no sky condition, no profile data
002	Campbell Scientific Message 2, no sky condition, profile data, 2048 range bins, 5 m resolution
003	Campbell Scientific Message 3, sky condition, no profile data
004	Campbell Scientific Message 4, sky condition and profile data, 2048 range bins, 5 m resolution
005*	Campbell Scientific Message 5, sky condition, no profile data, mixing layer height
006*	Campbell Scientific Message 6, sky condition, profile data, 2048 range bins, 5 m resolution, mixing layer height
101	CL31 Message 1, 770 range bins, 10 m resolution
102	CL31 Message 1, 385 range bins, 20 m resolution
103	CL31 Message 1, 1500 range bins, 5 m resolution
104	CL31 Message 1, 770 range bins, 5 m resolution
105	CL31 Message 1, No profile data
106	CL31 Message 1, Full CS135 output, 2048 range bins, 5 m resolution
107	CL31 Message 2, 770 range bins, 10 m resolution
108	CL31 Message 2, 385 range bins, 20 m resolution
109	CL31 Message 2, 1500 range bins, 5 m resolution
110	CL31 Message 2, 770 range bins, 5 m resolution
111	CL31 Message 2, No profile data
112	CL31 Message 2, Full CS135 output, 2048 range bins, 5 m resolution
113	CT25K message 1
114	CT25K message 6

* only available if MLH option is active

5.1.5 Measurement and message intervals

Message_interval is the message interval in seconds, 2 to 10 or 20 to 600 in steps of 10. '0' gives polled messages, the default is 10.

NOTE: this command may affect measurement parameters within the 'BS' command ('BS' can set non-standard measurement parameters) as follows:

```

If
Message_interval = 0
Measurement_Period = 10
BS_Av_Time = 2
Rolling_Average = 1

If
Measurement_Period = Message_interval = 2
BS_Av_Time = 1
Rolling_Average = 1

If
Message_interval > 2 and Message_interval < 10
Measurement_Period = Message_interval
BS_Av_Time = 2
Rolling_Average = 1

If
Message_interval >= 10
Measurement_Period = 10
BS_Av_Time = 2
Rolling_Average = Message_interval / 10. Maximum is 29
    
```

5.1.6 STATUS command

The STATUS command returns the following information:

Line	Example line output
1	Identification CS135 SN1000 ID 0
Description of the line sections	
Section	Description
CS135	Product name
SN1000	Sensor serial number
ID 0	Sensor identification number

Line	Example line output
2	Date Time 2012/01/10 11:39:46
Description of the line sections	
Section	Description
2012/01/10	Date in the format yyyy/mm/dd
11:39:46	Time in the format hh:mm:ss

Line	Example line output
3	DSP_OS A
Description of the line sections	
Section	Description
A	DSP OS revision number

Line	Example line output
4	TOP_OS 1
Description of the line sections	

Section	Description
A	TOP board OS revision number

Line	Example line output
5	PSU_OS 1
Description of the line sections	
Section	Description
A	PSU board OS revision number

Line	Example line output
6	Watchdog A
Description of the line sections	
Section	Description
A	Watchdog counter for unscheduled system resets

Line	Example line output
7	Serial A B C D
Description of the line sections	
Section	Description
A	Serial mode (<i>Note: Refer to the SERIAL command</i>)
B	Serial baud rate (<i>Note: Refer to the SERIAL command</i>)
C	Parity and stop bits (<i>Note: Refer to the SERIAL command</i>)
D	Receive to transmit delay time in RS485 mode (<i>Note: Refer to the SERIAL command</i>)

Line	Example line output
8	Heaters A B C D
Description of the line sections	
Section	Description
A	Hood blower mode
B	Internal heater mode
C	Laser heater mode
D	Heater/blower test interval in hours

Line	Example line output
9	MCFG X A B C D E
Description of the line sections	
Section	Description
X	Message interval (<i>Note: Refer to the MCFG command</i>)
A	Message ID A (<i>Note: Refer to the MCFG command</i>)
B	Message ID B (<i>Note: Refer to the MCFG command</i>)
C	Message ID C (<i>Note: Refer to the MCFG command</i>)
D	Message ID D (<i>Note: Refer to the MCFG command</i>)
E	Message ID E (<i>Note: Refer to the MCFG command</i>)

Line	Example line output
10	Angle A B C
Description of the line sections	
Section	Description
A	X axis tilt
B	Y axis tilt
C	Beam angle from vertical

Line	Example line output
11	Units A
Description of the line sections	
Section	Description
A	Measurement units and tilt correction. (<i>Note: Refer to the UNITS command</i>)

Line	Example line output
12	TRH A B C
Description of the line sections	
Section	Description
A	Sensor internal temperature reading in degrees Celsius.
B	Sensor internal humidity reading as a percentage
C	Sensors internal dew point value in degrees Celsius

Line	Example line output
13	T A B C D E F
Description of the line sections	
Section	Description
A	External fan blower assembly temperature in degrees Celsius
B	PSU internal temperature in degrees Celsius
C	TOP board laser monitor temperature in degrees Celsius
D	TOP board calibration LED temperature in degrees Celsius
E	Laser module temperature in degrees Celsius
F	Photo diode module temperature in degrees Celsius

Line	Example line output
14	SupplyVoltage A B
Description of the line sections	
Section	Description
A	DSP board supply voltage
B	PS135E internal supply voltage
C	Cyclic power cycle counter. Resets after 31 cycles

Line	Example line output
15	HOffset A
Description of the line sections	
Section	Description
A	Height offset reported in feet or metres dependent upon the UNITS command

Line	Example line output
16	Visibility Cap A
Description of the line sections	
Section	Description
A	Vertical visibility maximum range

Line	Example line output
17	LaserRunDays A
Description of the line sections	
Section	Description
A	Number of days that the laser module has been active for

Line	Example line output
18	WindowTX A
Description of the line sections	
Section	Description
A	Window transmittance %

Line	Example line output
19	BS A B C D E F (Note: refer to the BS command)
Description of the line sections	
Section	Description
A	Attenuated scale
B	Averaging time

C	Noise Gate
D	Measurement period
E	Rolling average
F	Message interval

Line	Example line output
20	MLH A B C D E F (<i>Note: refer to the MLH command</i>)
Description of the line sections	
Section	Description
A	Temporal filter
B	Range filter
C	STD width
D	Q1 threshold
E	Q2 threshold
F	Q3 threshold

Line	Example line output
21	Features A
Description of the line sections	
Section	Description
A	List of features enabled

Line	Example line output
22	Flags 0000 0000 0000
Description of the most significant alarm word (left side, bits going left to right). Each alarm word is a hexadecimal sum of all the error bits.	
Bit	Description
8000 XXXX XXXX	Units. feet = 0, metres = 8
4000 XXXX XXXX	<i>Reserved for future use</i>
2000 XXXX XXXX	<i>Reserved for future use</i>
1000 XXXX XXXX	<i>Reserved for future use</i>
0800 XXXX XXXX	DSP clock out of specification
0400 XXXX XXXX	Laser shut down due to operating temperature out of range
0200 XXXX XXXX	The lead acid battery voltage is reading low
0100 XXXX XXXX	Mains supply has failed (Required a PSU to be present)
0080 XXXX XXXX	The external heater blower assembly temperature is out of bounds
0040 XXXX XXXX	External heater blower failure
0020 XXXX XXXX	The PSUs internal temperature is high
0010 XXXX XXXX	PSU OS has failed its signature check
0008 XXXX XXXX	No communications between DSP and PSU
0004 XXXX XXXX	Photo diode and Laser windows are dirty. This can only be set if the laser is on
0002 XXXX XXXX	Tilt beyond limit set by user, default 45 degrees
0001 XXXX XXXX	No communications between DSP and inclinometer board

Description of the middle alarm word (middle word, bits going left to right)	
Bit	Description
XXXX 8000 XXXX	The sensors internal humidity is high
XXXX 4000 XXXX	Communications to the DSP boards temperature and humidity chip have failed
XXXX 2000 XXXX	DSP input supply voltage is low
XXXX 1000 XXXX	Self-test active
XXXX 0800 XXXX	Watch dog counter updated
XXXX 0400 XXXX	User setting stored in flash failed their signature checks
XXXX 0200 XXXX	DSP factory calibration stored in flash has failed its signature check
XXXX 0100 XXXX	DSP board OS signature test failed
XXXX 0080 XXXX	DSP board RAM test failed
XXXX 0040 XXXX	DSP boards on board PSUs are out of bounds
XXXX 0020 XXXX	TOP board non-volatile storage is corrupt
XXXX 0010 XXXX	TOP board OS signature test has failed
XXXX 0008 XXXX	TOP boards ADC and DAC are not within specifications

XXXX 0004 XXXX	TOP boards on board PSUs are out of bounds
XXXX 0002 XXXX	Communications have failed between TOP board and the DSP
XXXX 0001 XXXX	Photo diode background radiance is out of range

Description of the least significant alarm word (right side, bits going left to right)	
Bit	Description
XXXX XXXX 8000	Photo diode temperature is out of range
XXXX XXXX 4000	Photo diode is saturated
XXXX XXXX 2000	Photo diode calibrator temperature is out of range
XXXX XXXX 1000	Photo diode calibrator has failed
XXXX XXXX 0800	The sensor could not reach the desired gain levels
XXXX XXXX 0400	Laser run time has been exceeded
XXXX XXXX 0200	Laser temperature out of range
XXXX XXXX 0100	Laser thermistor failure
XXXX XXXX 0080	Laser is obscured. This can only be set if the laser is on
XXXX XXXX 0040	Laser did not achieve significant output power
XXXX XXXX 0020	Laser max power exceeded
XXXX XXXX 0010	Laser max drive current exceeded
XXXX XXXX 0008	Laser power monitor temperature out of range
XXXX XXXX 0004	Laser power monitor test fail
XXXX XXXX 0002	Laser shutdown by top board
XXXX XXXX 0001	Laser is off

5.1.7 Message Polling

The command 'POLL *Sensor_ID* *Message_ID* ' requests the message *Message_ID* from sensor *Sensor_ID*.
Where *Message_ID* is a CS135message type as defined in Section 5.1.4.

The following xample shows to use the CS135 POLL command to request preconfigured message outputs.

First configure the CS135 to use polling mode from the terminal interface via the “MCFG” command as follows:

```

"CS135> MCFG 0"
"0 1 0 0 0 0"
    
```

This configures the CS135 into polling mode leaving your message output configurations unchanged. Exit the terminal by typing the “close” command. This will save the changes you just made.

```

"CS135> CLOSE"
"COMMAND CLOSED"
    
```

Any automatic message outputs should not have stopped. Type the “POLL” command as shown below to verify that the system is working as expected. Note: Once you have exited the terminal characters will not be automatically echoed back to you.

```

"POLL 0"
    
```

This should return all messages you have set via the MCFG command. In this example, only one message output was set, the default message. So the POLL command will return text similar to that shown below. Note: If you have no message configured (i.e. MCFG returned 0 0 0 0 0 0) then nothing will be returned from the command you just typed.

```

`CS0100001
10 100 12345 // // // // 0000000000000000"
abcd

```

The following example shows how to use the POLL command to request a specific message output type.

First configure the CS135 into polling mode as shown in the example above and exit the terminal interface. To poll the CS135 for a particular message type, type the following.

```

`POLL 0 113"

```

The example text above will request the "CT25K Message 1" and should look similar to the text below.

```

`CT00010
10 12345 // // // // 00000f80"

```

5.1.8 Loading a New Operating System (OS)

A new OS can be entered with the LOADOS *module* command. Note three different modules each have their own OS. The parameter *module* loads a new operating system into different modules as follows:

Module =1, DSP (file type *.ldr)

Module =2, TOP (file type *.hex)

Module =3, PSU (file type*.hex)

Module =4, DSP, TOP & PSU as one file, type *.ldr. This is the usual method.

NOTE

The new OS must be sent using xmodem protocol.

To load a new operating system :

Enter terminal mode by typing "Open 0" (for a sensor with the default ID "0")

This will return the prompt "CS135>"

Type the command "LOADOS_4"

The CS135 will respond:

```

"Load OS into DSP
DO NOT REMOVE POWER DURING OS UPDATE!!!
Waiting for xmodem"

```

At this point use your terminal emulator to send the appropriate file. Loading the OS could take a few minutes.

When the process is complete the CS135 will return the message:

```

"Wait 40 sec for OS to restart"

```

after which it will resume operation according to the previously set operating parameters. It will no longer be in terminal mode.

To load a new operating system into a CS135 with an OS between 4 and 7

Enter terminal mode by typing "Open 0" (for a sensor with the default ID "0")

This will return the prompt "CS135>"

Type the command "LOADOS 1"

The CS135 will respond:

"Load OS into DSP

DO NOT REMOVE POWER DURING OS UPDATE!!!

Waiting for xmodem"

At this point use your terminal emulator to send the *.ldr file using xmodem protocol.

Loading the OS could take a few minutes.

When the process is complete the CS135 will return the message:

"Wait 40 sec for OS to restart" after which it will resume operation according to the previously set operating parameters. It will no longer be in terminal mode.

DO NOT REBOOT THE CS135 AT THIS POINT

Again enter terminal mode by typing "Open 0" (for a sensor with the default ID "0")

This will return the prompt "CS135>"

This time type the command "LOADOS 4"

The CS135 will respond:

"Load OS into DSP

DO NOT REMOVE POWER DURING OS UPDATE!!!

Waiting for xmodem"

At this point again use your terminal emulator to send the *.ldr file using xmodem protocol.

Loading the OS could take a few minutes.

When the process is complete the CS135 will return the message:

"Wait 40 sec for OS to restart" after which it will resume operation according to the previously set operating parameters. It will no longer be in terminal mode.

To load a new operating system into a CS135 with an OS between 1 and 3

Operating systems earlier than 4 will need the boot loader updating, use the LOADOS 1 command, not LOADOS 4, before a new DSP OS can be uploaded so the first time the OS is loaded a verify error will be reported (this is normal) as follows:

"Error writing word 32768

Verify OS

Error verifying word 327680 37020 4236"

You will then need to `reboot` and then load the OS using the terminal command `LOADOS 4` to correctly load the OS without errors.

The process is as follows:

Enter terminal mode by typing "Open 0" (for a sensor with the default ID

“0”)

This will return the prompt “CS135>”

Type the command “LOADOS 1”

The CS135 will respond:

“Load OS into DSP

DO NOT REMOVE POWER DURING OS UPDATE!!!

Waiting for xmodem”

At this point use your terminal emulator to send the *.ldr file using xmodem protocol.

Loading the OS could take a few minutes.

When the process is complete the CS135 will return the message:

“Error writing word 32768

Verify OS

Error verifying word 327680 37020 4236”

NOW REBOOT THE CS135 USING THE “REBOOT” COMMAND

Wait 40 sec for OS to restart after which it will resume operation according to the previously set operating parameters. It will no longer be in terminal mode.

Again enter terminal mode by typing “Open 0” (for a sensor with the default ID “0”)

This will return the prompt “CS135>”

This time type the command “LOADOS 4”

The CS135 will respond:

“Load OS into DSP

DO NOT REMOVE POWER DURING OS UPDATE!!!

Waiting for xmodem”

At this point again use your terminal emulator to send the *.ldr file again using xmodem protocol .

Loading the OS could take a few minutes.

When the process is complete the CS135 will return the message:

“Wait 40 sec for OS to restart” after which it will resume operation according to the previously set operating parameters. It will no longer be in terminal mode.

It is good practice to re-boot the sensor after loading a new OS.

5.1.9 Stratocumulus backscatter calibration

The command ‘SCCAL’ allows a simple Stratocumulus backscatter calibration of the scatter coefficient measurements. This requires a human observer to confirm a stable Stratocumulus cloud layer between 250 m to 2500 m without holes, precipitation or reduced visibility and has been stable for at least 10 minutes prior to running this command.

Measurement_Period should be set to 10s. See Table 5.1.

A detailed description of this technique is given in: - Ewan J. O’Connor, Anthony J. Illingworth, and Robin J. Hogan, 2004: A Technique for Autocalibration of Cloud Lidar. *Journal of Atmospheric and Ocean Technology*, **21**, pp 777 - 786

Enter terminal mode by typing “Open 0” (for a sensor with the default ID “0”)

This will return the prompt “CS135>”

Type the command “SCCAL”

The CS135 will respond:

“Stratocumulus calibration.

Enter height above sea level (m)? Press enter to continue:”

Enter the sensor height above sea level, for example 70 m and type return.

The CS135 will respond “70 m entered, is this correct? 'Y', 'N' or 'Q' ”

Type “Y” to confirm or if you have entered an incorrect number type “N” and you will be able to replace it. Typing “Q” will quit the calibration and return to the terminal command prompt.

The CS135 will now respond:

“For correct calibration a trained human observer must confirm that the layer is between 250 m to 2500 m and has been stable for at least 10 minutes without drizzle. Has the Stratocumulus been stable for at least 10 minutes? 'Y' or 'N' ”

To confirm type “Y”

The CS135 will respond:

“Old Stratocumulus calibration = 0.0382

New Stratocumulus calibration parameters = 0.0258 70 1328

Do you want to apply this calibration? 'Y' or 'N' ”

In this example 70 is the height of the sensor above sea level previously entered and 1210 is the cloud base in metres above the sensor.

Type “Y” to confirm and the CS135 will respond:

“Calibration saved.”

The following error messages may appear during the process.

- Error ... Time out.
- Error ... Cloud not detected or height not within limits (250 m to 2500 m).
- Try again when layer is stable.
- Error ... Not enough data available try again in 10 minutes.

5.1.10 CRC Codes on terminal commands

If CRC16-CCITT on mode is set using the “Terminal” command, all terminal commands need a CRC. A semi-colon is used to indicate start of CRC in 4 byte ASCII hex, for example “open 0;d2d5”. The CRC is calculated either from the start of a new line or after a [STX] up to but not including the semi-colon. ETX can follow the CRC if required.

The valid CRC can be found for any command by entering the command with the 4 character CRC after the semi-colon replaced with “????”. For example entering

“open 0;???” gives the response “[CRLF]CRC>D2D5<CRC[CRLF]” so d2d5 is the CRC.

The CRC is not case sensitive.

The table below gives some commonly used CRC codes.

Terminal Command	CRC
Open 0	233A
Close	D94E
Status	7CE5
Password	DF20
Terminal 0 (this command will remove CRC checking)	B576
Defaults	7D8E
Serial	7FCE

5.1.11 Service command

The service command triggers the CS135 to go through a series of tests including a test that requires a white test surface (thick white paper or card will do) to be placed on the CS135 windows. The response is similar to the following:

Initially the CS135 will output a ‘STATUS’ message. It will then go through various self-test routines and before requesting a white test surface to be placed over each of the windows in turn. This process is as follows:

```
self test, please wait
wait for new measurement.....
Place white test surface onto detector window (left hand side fan at the top)
Press enter key to continue
```

At this point cover the detector window and press the ‘Enter’ key.

```
wait for new measurement.....
Place white test surface onto laser window (right hand side fan at the top)
Press enter key to continue
```

At this point cover the laser window and press the ‘Enter’ key.

```
wait for new measurement.....
Remove white test surface from laser window. Press enter key to continue
```

When this is complete the CS135 will output a string of diagnostic data similar. This can be very useful for a Campbell Scientific engineer investigating problems with the CS135.

Finally the CS135 will list any faults found as shown below:

```
***** CS135 FAULT list *****
FAULT - external heater/blower thermistor
FAULT - detector dirty windows with white test surface
FAULT - max APD gain not achieved
```

Otherwise it will report the following message:

```
***** CS135 has PASSED all tests *****
```

5.1.12 Locked features

Optional features such as Mixing Layer Height assessment are protected by a 'key'. They are enabled by typing the command 'UNLOCK' followed by the key. This is specific to the individual CS135 and only has to be entered once.

5.2 Restoring Factory Defaults

Factory defaults can be restored using the terminal mode command "DEFAULTS". Alternatively, they can be set using a push switch on the DSP as shown in Fig 5.1. The cover and enclosure lid first have to be removed. Please refer to Sections 4.6.1 and 4.6.2.

If the switch is pushed for four seconds the CS135 will reboot in exactly the same way as the REBOOT terminal command. If it is held closed while the CS135 is powered off and on again it will return to factory defaults. Note that to power cycle the CS135 the battery has to be disconnected as well as switching the main power off and on.

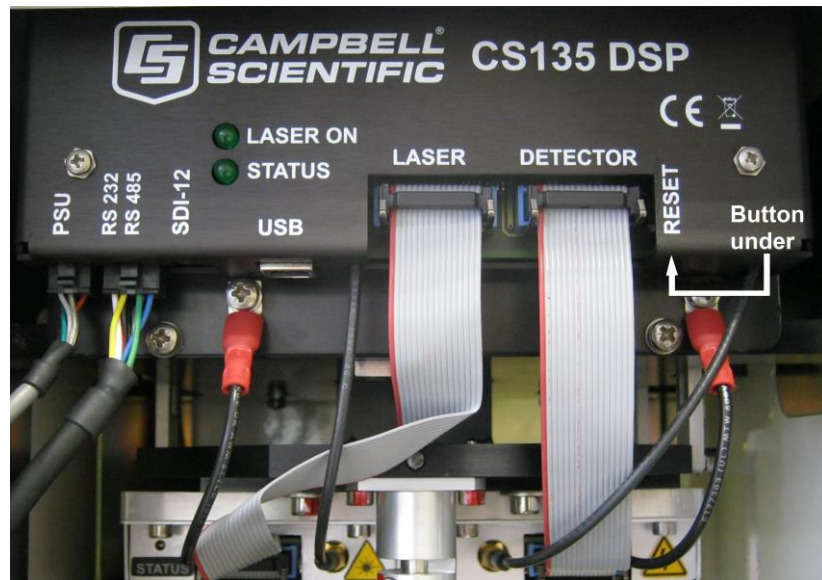

Fig 5.1 Restoring Factory Defaults

NOTE Opening the access door **MUST** be carried out by a competent person.

5.3 LED Indicator

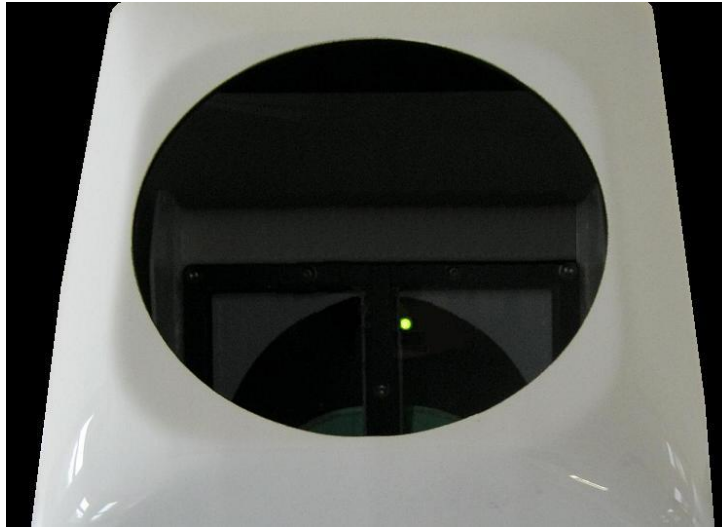

Figure 5.2 LED indicator

A green LED is visible through the window, see Fig 5.2. It will give 0.5 second flashes as follows:

- 1 flash every 10 seconds = OK, no fault
- 2 flashes every 10 seconds = warning (possible degraded performance)
- 3 flashes every 10 seconds = alarm (measurements not possible)

6. Messages

6.1 Data Messages General

The CS135 can provide a variety of data message types to allow efficient output of data. Not all messages provide the full information available but these messages may be more efficient in terms of data storage and transmission.

CL31 and CT25K messages follow formats used by common existing CL31 and CT25K sensors allowing easier replacement or network expansion.

6.2 Checksums used in CS135 messages

This is based on the CCITT-16 CRC with the output XOR'd with Hex 0xFFFF and outputs a two byte CRC in hex format (four ASCII characters). The CRC is calculated on all characters after the SOH character up to and including the ETX character.

The following example 'C' code calculates the CS135 checksum.

Note - 'shorts' are 16 bits long and 'ints' are 32 bits long.

```
// -----  
-----  
// Calculate CRC16  
// buf is a pointer to the input string  
// len is the length of the input string  
// -----  
-----  
unsigned short crc16(char *buffer, int length)  
{  
    unsigned short crc;  
    unsigned short m;  
    int i, j;  
  
    crc = 0xFFFF;  
  
    for (i=0; i < length; ++i)  
    {  
        crc ^= buffer[i] << 8;  
  
        for (j=0; j<8; ++j){  
            m = (crc & 0x8000) ? 0x1021 : 0;  
            crc <<= 1;  
            crc ^= m;  
        }  
    }  
    crc ^= 0xFFFF;  
    return crc;  
}
```

6.3 CS Messages

Message 001 (no profile, no sky condition) – Default message

LINE 1

SOH CS ID OS N STX CR LF

where

SOH = Start-of-Heading character

CS = Always "CS"

ID(1 character) = A single ASCII character, 0-9, a - z or A - Z, case sensitive. Default ID = 0

OS (3 characters) = Operating system, 001 ... 999

N (3 characters) = Message number

STX = Start-of-Text Character

CR LF = Carriage Return + Line Feed

LINE 2

S WA tr h1 h2 h3 h4 flags CR LF

where

S (1 character) = message status:

0 = No significant backscatter

1 = One cloud base detected

2 = Two cloud bases detected

3 = Three cloud bases detected

4 = Four cloud bases detected

5 = Full obscuration determined but no cloud base detected

6 = Some obscuration detected but determined to be transparent

/ = Raw data input to algorithm missing or suspect

WA (1 character) = Warning or alarm status:

0 = No alarm or warning

W = Warning

A = Alarm

tr (3 characters) = Window transmission, %

h1 (5 characters) = 1st Height

If detection status is 1, 2, 3 or 4 $h1$ = Lowest cloud base reported

If detection status is 5 $h1$ = Vertical visibility as calculated

If detection status is 0 or 6 $h1$ = "/////"

$h2$ (5 characters) = 2nd Height

If detection status is 2, 3 or 4 $h2$ = Second cloud base reported

If detection status is 5 $h2$ = Highest signal received

If detection status is 0, 1, or 6 $h2$ = "/////"

$h3$ (5 characters) = 3rd Height

If detection status is 3 or 4 $h3$ = Third cloud base reported

If detection status is 0, 1, 2, 5 or 6 $h3$ = "/////"

$h4$ (5 characters) = 4th Height

If detection status is 4 $h4$ = Fourth cloud base reported

If detection status is 0, 1, 2, 3 or 5 $h4$ = "/////"

$flags$ (12 characters in 3 groups of 4) = Alarm or warning information

Description of the most significant alarm word (left side, bits going left to right). Each alarm word is a hexadecimal sum of all the error bits.	
Bit	Description
8000 XXXX XXXX	Units. Feet = 0, metre = 1.
4000 XXXX XXXX	<i>Reserved for future use</i>
2000 XXXX XXXX	<i>Reserved for future use</i>
1000 XXXX XXXX	<i>Reserved for future use</i>
0800 XXXX XXXX	DSP clock out of specification
0400 XXXX XXXX	Laser shut down due to operating temperature out of range
0200 XXXX XXXX	The lead acid battery voltage is reading low
0100 XXXX XXXX	Mains supply has failed (Required a PSU to be present)
0080 XXXX XXXX	The external heater blower assembly temperature is out of bounds
0040 XXXX XXXX	External heater blower failure
0020 XXXX XXXX	The PSUs internal temperature is high
0010 XXXX XXXX	PSU OS has failed its signature check
0008 XXXX XXXX	No communications between DSP and PSU
0004 XXXX XXXX	Photo diode and Laser windows are dirty. This can only be set if the laser is on
0002 XXXX XXXX	Tilt beyond limit set by user, default 45 degrees
0001 XXXX XXXX	No communications between DSP and inclinometer board

Description of the middle alarm word (middle word, bits going left to right)	
Bit	Description
XXXX 8000 XXXX	The sensors internal humidity is high
XXXX 4000 XXXX	Communications to the DSP board temperature and humidity chip have failed
XXXX 2000 XXXX	DSP input supply voltage is low
XXXX 1000 XXXX	Self-test active
XXXX 0800 XXXX	Watch dog counter updated
XXXX 0400 XXXX	User setting stored in flash failed their signature checks
XXXX 0200 XXXX	DSP factory calibration stored in flash has failed its signature check
XXXX 0100 XXXX	DSP board OS signature test failed
XXXX 0080 XXXX	DSP board RAM test failed
XXXX 0040 XXXX	DSP boards on board PSUs are out of bounds
XXXX 0020 XXXX	TOP board non-volatile storage is corrupt
XXXX 0010 XXXX	TOP board OS signature test has failed

XXXX 0008 XXXX	TOP boards ADC and DAC are not within specifications
XXXX 0004 XXXX	TOP boards on board PSUs are out of bounds
XXXX 0002 XXXX	Communications have failed between TOP board and the DSP
XXXX 0001 XXXX	Photo diode background radiance is out of range

Description of the least significant alarm word (right side, bits going left to right)	
Bit	Description
XXXX XXXX 8000	Photo diode temperature is out of range
XXXX XXXX 4000	Photo diode is saturated
XXXX XXXX 2000	Photo diode calibrator temperature is out of range
XXXX XXXX 1000	Photo diode calibrator has failed
XXXX XXXX 0800	The sensor could not reach the desired gain levels
XXXX XXXX 0400	Laser run time or maximum laser drive current has been exceeded
XXXX XXXX 0200	Laser temperature out of range
XXXX XXXX 0100	Laser thermistor failure
XXXX XXXX 0080	Laser is obscured. This can only be set if the laser is on
XXXX XXXX 0040	Laser did not achieve significant output power
XXXX XXXX 0020	Laser max power exceeded
XXXX XXXX 0010	Laser max drive current exceeded
XXXX XXXX 0008	Laser power monitor temperature out of range
XXXX XXXX 0004	Laser power monitor test fail
XXXX XXXX 0002	Laser shutdown by top board
XXXX XXXX 0001	Laser is off

CR LF = Carriage Return and Line Feed

LINE 3

ETX CRC16 EOT CR LF

where

ETX = End-of-Text character

CRC16 (4 characters) = CRC16-CCITT Checksum

EOT = End-of-Transmission character

CRLF = Carriage Return + Line Feed

MESSAGE 002 (Profile, no sky condition)

LINE 1

SOH CS ID OS N STX CR LF

where

SOH = Start-of-Heading character

CS = Always "CS"

ID(1 character) = A single ASCII character, 0-9, a - z or A - Z, case sensitive. Default ID = 0

OS (3 characters) = Operating system, 001 ... 999

N (3 characters) = Message number

STX = Start-of-Text Character

CR LF = Carriage Return + Line Feed

LINE 2

S WA_tr_h1_h2_h3_h4_flags CR LF

where

S (1 character) = message status:

0 = No significant backscatter

1 = One cloud base detected

2 = Two cloud bases detected

3 = Three cloud bases detected

4 = Four cloud bases detected

5 = Full obscuration determined but no cloud base detected

6 = Some obscuration detected but determined to be transparent

/ = Raw data input to algorithm missing or suspect

WA (1 character) = Warning or alarm status:

0 = No alarm or warning

W = Warning

A = Alarm

tr (3 characters) = Window transmission, %

h1 (5 characters) = 1st Height

If detection status is 1, 2, 3 or 4 *h1* = Lowest cloud base reported

If detection status is 5 *h1* = Vertical visibility as calculated

If detection status is 0 or 6 $h1 = "/////"$

$h2$ (5 characters) = 2nd Height

If detection status is 2, 3 or 4 $h2$ = Second cloud base reported

If detection status is 5 $h2$ = Highest signal received

If detection status is 0, 1, or 6 $h2 = "/////"$

$h3$ (5 characters) = 3rd Height

If detection status is 3 or 4 $h3$ = Third cloud base reported

If detection status is 0, 1, 2, 5 or 6 $h3 = "/////"$

$h4$ (5 characters) = 4th Height

If detection status is 4 $h4$ = Fourth cloud base reported

If detection status is 0, 1, 2, 3 or 5 $h4 = "/////"$

$flags$ (12 characters in 3 groups of 4) = Alarm or warning information.

Refer to Message 001 for a breakdown of the flags.

$CR LF$ = Carriage Return and Line Feed

LINE 3

$scale_res_n_energy_lt_ti_bl_pulse_rate_sum$ $CR LF$

where

$scale$ (5 characters) = Attenuated_SCALE parameter, %, 0 ... 99999. 100% is default

res (2 characters) = Backscatter profile resolution in metres.

n (4 characters) = Profile length

$energy$ (3 characters) = Laser pulse energy, %.

lt (3 characters including leading +/-) = Laser temperature, degrees C

ti (2 characters) = Total tilt angle, degrees

bl (4 characters) = Background light, millivolts at internal ADC input (0 ... 2500)

$pulse$ (4 characters) = Pulse quantity x 1000 (0000-9999)

$rate$ (2 characters) = Sample rate, MHz, (00-99)

sum = Sum of detected and normalized backscatter, 0 ... 999. Multiplied by scaling factor times 10^4 . At scaling factor 100 the SUM range 0 ... 999 corresponds to integrated backscatter 0 ... 0. srad^{-1} .

$CR LF$ = Carriage Return + Line Feed

MESSAGE 003 (no profile, sky condition)**LINE 1**

SOH CS ID OS N STX CR LF

where

SOH = Start-of-Heading character

CS = Always "CS"

ID(1 character) = A single ASCII character, 0-9, a - z or A - Z, case sensitive. Default ID = 0

OS (3 characters) = Operating system, 001 ... 999

N (3 characters) = Message number

STX = Start-of-Text Character

CR LF = Carriage Return + Line Feed

LINE 2

S WA_tr_h1_h2_h3_h4_flags CR LF

where

S (1 character) = message status:

0 = No significant backscatter

1 = One cloud base detected

2 = Two cloud bases detected

3 = Three cloud bases detected

4 = Four cloud bases detected

5 = Full obscuration determined but no cloud base detected

6 = Some obscuration detected but determined to be transparent

/ = Raw data input to algorithm missing or suspect

WA (1 character) = Warning or alarm status:

0 = No alarm or warning

W = Warning

A = Alarm

tr (3 characters) = Window transmission, %

h1 (5 characters) = 1st Height

If detection status is 1, 2, 3 or 4 *h1* = Lowest cloud base reported

If detection status is 5 *h1* = Vertical visibility as calculated

If detection status is 0 or 6 $h1 = "////"$

$h2$ (5 characters) = 2nd Height

If detection status is 2, 3 or 4 $h2 =$ Second cloud base reported

If detection status is 5 $h2 =$ Highest signal received

If detection status is 0, 1, 5 or 6 $h2 = "////"$

$h3$ (5 characters) = 3rd Height

If detection status is 3 or 4 $h3 =$ Third cloud base reported

If detection status is 0, 1, 2, 5 or 6 $h3 = "////"$

$h4$ (5 characters) = 4th Height

If detection status is 4 $h4 =$ Fourth cloud base reported

If detection status is 0, 1, 2, 3 or 5 $h4 = "////"$

$flags$ (12 characters in 3 groups of 4) = Alarm or warning information.

Refer to Message 001 for a breakdown of the flags.

$CR LF$ = Carriage Return and Line Feed

LINE 3

$_d_h1_d2_h2_d3_h3_d4_h4_d5_h5$ $CR LF$

(note spaces)

where

d (2 characters) = Data available

$_0$ to $_8$ Amount of lowest layer in oktas

$_9$ Vertical visibility only available

-1 No sky condition data available

99 Insufficient data

$h1$ (4 characters) = Height of the lowest cloud layer in 10s of metres or 100s of feet

$d2$ (1 character) = Cloud amount of the 2nd layer in oktas

$h2$ (4 characters) = Height of the 2nd cloud layer in 10s of metres or 100s of feet, if no 2nd layer is reported $h2 = '////'$.

$d3$ (1 character) = Cloud amount of the 3rd layer in oktas

$h3$ (4 characters) = Height of the 3rd cloud layer in 10s of metres or 100s of feet, if no 3rd layer is reported $h3 = '////'$.

$d4$ (1 character) = Cloud amount of the 4th layer in oktas

$h4$ (4 characters) = Height of the 4th cloud layer in 10s of metres or 100s of feet, if no 4th layer is reported $h4 = '////'$.

d5 (1 character) = Cloud amount of the 5th layer in oktas

h5 (4 characters) = Height of the 5th cloud layer in 10s of metres or 100s of feet, if no 5th layer is reported *h5* = '////'.

CR LF = Carriage Return + Line Feed

LINE 4

ETX CRC16 EOT CR LF

where

ETX = End-of-Text character

CRC16 (4 characters) = CRC16-CCITT Checksum

EOT = End-of-Transmission character

CR LF = Carriage Return + Line Feed

MESSAGE 004 (profile, sky condition)

LINE 1

SOH CS ID OS N STX CR LF

where

SOH = Start-of-Heading character

CS = Always "CS"

ID (1 character) = A single ASCII character, 0-9, a - z or A - Z, case sensitive. Default ID = 0

OS (3 characters) = Operating system, 001 ... 999

N (3 characters) = Message number

STX = Start-of-Text Character

CR LF = Carriage Return + Line Feed

LINE 2

S WA_tr_h1_h2_h3_h4_flags CR LF

where

S (1 character) = message status:

0 = No significant backscatter

1 = One cloud base detected

2 = Two cloud bases detected

3 = Three cloud bases detected

4 = Four cloud bases detected

5 = Full obscuration determined but no cloud base detected

6 = Some obscuration detected but determined to be transparent

/ = Raw data input to algorithm missing or suspect

WA (1 character) = Warning or alarm status:

0 = No alarm or warning

W = Warning

A = Alarm

Tr (3 characters) = Window transmission, %

h1 (5 characters) = 1st Height

If detection status is 1, 2, 3 or 4 *h1* = Lowest cloud base reported

If detection status is 5 *h1* = Vertical visibility as calculated

If detection status is 0 or 6 $h1 = "////"$

$h2$ (5 characters) = 2nd Height

If detection status is 2, 3 or 4 $h2$ = Second cloud base reported

If detection status is 5 $h2$ = Highest signal received

If detection status is 0, 1, or 6 $h2 = "////"$

$h3$ (5 characters) = 3rd Height

If detection status is 3 or 4 $h3$ = Third cloud base reported

If detection status is 0, 1, 2, 5 or 6 $h3 = "////"$

$h4$ (5 characters) = 4th Height

If detection status is 4 $h4$ = Fourth cloud base reported

If detection status is 0, 1, 2, 3 or 5 $h4 = "////"$

$flags$ (12 characters in 3 groups of 4) = Alarm or warning information.

Refer to Message 001 for a breakdown of the flags.

$CR LF$ = Carriage Return + Line Feed.

LINE 3

$_d_h1h1h1_d2_h2h2h2_d3_h3h3h3_d4_h4h4h4_d5_h5h5h5$ $CR LF$

(note spaces)

where

d (2 characters) = Data available

$_0$ to $_8$ Amount of lowest layer in oktas

$_9$ Vertical visibility only available

-1 No sky condition data available

99 Insufficient data

$h1$ (4 characters) = Height of the lowest cloud layer in 10s of metres or 100s of feet

$d2$ (1 character) = Cloud amount of the 2nd layer in oktas

$h2$ (4 characters) = Height of the 2nd cloud layer in 10s of metres or 100s of feet, if no 2nd layer is reported $h2 = '////'$.

$d3$ (1 character) = Cloud amount of the 3rd layer in oktas

$h3$ (4 characters) = Height of the 3rd cloud layer in 10s of metres or 100s of feet, if no 3rd layer is reported $h3 = '////'$.

$d4$ (1 character) = Cloud amount of the 4th layer in oktas

$h4$ (4 characters) = Height of the 4th cloud layer in 10s of metres or 100s of feet, if no 4th layer is reported $h4 = '////'$.

$d5$ (1 character) = Cloud amount of the 5th layer in oktas

LINE 6

ETX CRC16 EOT CR LF

where

ETX = End-of-Text character

CRC16 (4 characters) = CRC16-CCITT Checksum

EOT = End-of-Transmission character

CR LF = Carriage Return + Line Feed

**MESSAGE 005 (no profile, sky condition, mixing layer heights)
Only available if a key is entered (see Section 5.1.11)**

LINE 1

SOH CS ID OS N STX CR LF

where

SOH = Start-of-Heading character

CS = Always "CS"

ID (1 character) = A single ASCII character, 0-9, a - z or A - Z, case sensitive. Default ID = 0

OS (3 characters) = Operating system, 001 ... 999

N (3 characters) = Message number

STX = Start-of-Text Character

CR LF = Carriage Return + Line Feed

LINE 2

S WA_tr_h1_h2_h3_h4_flags CR LF

where

S (1 character) = message status:

0 = No significant backscatter

1 = One cloud base detected

2 = Two cloud bases detected

3 = Three cloud bases detected

4 = Four cloud bases detected

5 = Full obscuration determined but no cloud base detected

6 = Some obscuration detected but determined to be transparent

/ = Raw data input to algorithm missing or suspect

WA (1 character) = Warning or alarm status:

0 = No alarm or warning

W = Warning

A = Alarm

tr (3 characters) = Window transmission, %

h1 (5 characters) = 1st Height

If detection status is 1, 2, 3 or 4 *h1* = Lowest cloud base reported

If detection status is 5 *h1* = Vertical visibility as calculated

If detection status is 0 or 6 *h1* = "/////"

h2 (5 characters) = 2nd Height

If detection status is 2, 3 or 4 *h2* = Second cloud base reported

If detection status is 5 *h2* = Highest signal received

If detection status is 0, 1, 5 or 6 *h2* = "/////"

h3 (5 characters) = 3rd Height

If detection status is 3 or 4 *h3* = Third cloud base reported

If detection status is 0, 1, 2, 5 or 6 *h3* = "////"

h4 (5 characters) = 4th Height

If detection status is 4 *h4* = Fourth cloud base reported

If detection status is 0, 1, 2, 3, 5 or 6 *h4* = "////"

flags (12 characters in 3 groups of 4) = Alarm or warning information.

Refer to Message 001 for a breakdown of the flags.

CR LF = Carriage Return and Line Feed

LINE 3

_d_h1__d2_h2__d3_h3__d4_h4__d5_h5 CR LF

(note spaces)

where

d (2 characters) = Data available

_0 to *_8* Amount of lowest layer in oktas

_9 Vertical visibility only available

-1 No sky condition data available

99 Insufficient data

h1 (4 characters) = Height of the lowest cloud layer in 10s of metres or 100s of feet

d2 (1 character) = Cloud amount of the 2nd layer in oktas

h2 (4 characters) = Height of the 2nd cloud layer in 10s of metres or 100s of feet, if no 2nd layer is reported *h2* = '////'.

d3 (1 character) = Cloud amount of the 3rd layer in oktas

h3 (4 characters) = Height of the 3rd cloud layer in 10s of metres or 100s of feet, if no 3rd layer is reported *h3* = '////'.

d4 (1 character) = Cloud amount of the 4th layer in oktas

h4 (4 characters) = Height of the 4th cloud layer in 10s of metres or 100s of feet, if no 4th layer is reported *h4* = '////'.

d5 (1 character) = Cloud amount of the 5th layer in oktas

h5 (4 characters) = Height of the 5th cloud layer in 10s of metres or 100s of feet, if no 5th layer is reported *h5* = '////'.

CR LF = Carriage Return + Line Feed

LINE 4

mh1_q1_mh2_q2_mh3_q3

where

mh1 (5 characters) = height of the 1st MLH in metres

q1 (5 characters) = quality parameter of the 1st MLH

mh2 (5 characters) = height of the 2nd MLH in metres

q2 (5 characters) = quality parameter of the 2nd MLH

mh3 (5 characters) = height of the 3rd MLH in metres

q3 (5 characters) = quality parameter of the 3rd MLH

If there are no mixing layers detected, or less than 3, then missing data is shown as “/////”. If the MLH option is not activated then all fields in line 4 are “/////”.

LINE 5

ETX CRC16 EOT CR LF

where

ETX = End-of-Text character

CRC16 (4 characters) = CRC16-CCITT Checksum

EOT = End-of-Transmission character

CR LF = Carriage Return + Line Feed

MESSAGE 006 (profile, sky condition, mixing layer heights)
Only available if a key is entered (see Section 5.1.11)

LINE 1

SOH CS ID OS N STX CR LF

where

SOH = Start-of-Heading character

CS = Always "CS"

ID (1 character) = A single ASCII character, 0-9, a - z or A - Z, case sensitive. Default ID = 0

OS (3 characters) = Operating system, 001 ... 999

N (3 characters) = Message number

STX = Start-of-Text Character

CR LF = Carriage Return + Line Feed

LINE 2

S WA_tr_h1_h2_h3_h4_flags CR LF

where

S (1 character) = message status:

0 = No significant backscatter

1 = One cloud base detected

2 = Two cloud bases detected

3 = Three cloud bases detected

4 = Four cloud bases detected

5 = Full obscuration determined but no cloud base detected

6 = Some obscuration detected but determined to be transparent

/ = Raw data input to algorithm missing or suspect

WA (1 character) = Warning or alarm status:

0 = No alarm or warning

W = Warning

A = Alarm

tr (3 characters) = Window transmission, %

h1 (5 characters) = 1st Height

If detection status is 1, 2, 3 or 4 *h1* = Lowest cloud base reported

If detection status is 5 *h1* = Vertical visibility as calculated

If detection status is 0 or 6 *h1* = "/////"

h2 (5 characters) = 2nd Height

If detection status is 2, 3 or 4 *h2* = Second cloud base reported

If detection status is 5 *h2* = Highest signal received

If detection status is 0, 1, 5 or 6 *h2* = "/////"

h3 (5 characters) = 3rd Height

If detection status is 3 or 4 *h3* = Third cloud base reported

If detection status is 0, 1, 2, 5 or 6 *h3* = "/////"

h4 (5 characters) = 4th Height

If detection status is 4 *h4* = Fourth cloud base reported

If detection status is 0, 1, 2, 3, 5 or 6 *h4* = "/////"

flags (12 characters in 3 groups of 4) = Alarm or warning information.

Refer to Message 001 for a breakdown of the flags.

CR LF = Carriage Return and Line Feed

LINE 3

_d_h1__d2_h2__d3_h3__d4_h4__d5_h5 CR LF

(note spaces)

where

d (2 characters) = Data available

_0 to *_8* Amount of lowest layer in oktas

_9 Vertical visibility only available

-1 No sky condition data available

99 Insufficient data

h1 (4 characters) = Height of the lowest cloud layer in 10s of metres or 100s of feet

d2 (1 character) = Cloud amount of the 2nd layer in oktas

h2 (4 characters) = Height of the 2nd cloud layer in 10s of metres or 100s of feet, if no 2nd layer is reported *h2* = '////'.

d3 (1 character) = Cloud amount of the 3rd layer in oktas

h3 (4 characters) = Height of the 3rd cloud layer in 10s of metres or 100s of feet, if no 3rd layer is reported *h3* = '////'.

d4 (1 character) = Cloud amount of the 4th layer in oktas

h4 (4 characters) = Height of the 4th cloud layer in 10s of metres or 100s of feet, if no 4th layer is reported *h4* = '////'.

d5 (1 character) = Cloud amount of the 5th layer in oktas

h5 (4 characters) = Height of the 5th cloud layer in 10s of metres or 100s of feet, if no 5th layer is reported *h5* = '////'.

CR LF = Carriage Return + Line Feed

LINE 4

scale_res_n_energy_lt_tr_ti_bl_pulse_rate_sum CR LF

where

scale (5 characters) = Scale parameter, %, 0 ... 99999. 100% is default

res (2 characters) = Backscatter profile resolution in metres.

n (4 characters) = Profile length

energy (3 characters) = Laser pulse energy, %.

lt (3 characters including leading +/-) = Laser temperature, degrees C

ti (2 characters) = Total tilt angle, degrees

bl (4 characters) = Background light, millivolts at internal ADC input (0 ... 2500)

pulse (4 characters) = Pulse quantity x 1000 (0000-9999)

rate (2 characters) = Sample rate, MHz, (00-99)

sum = Sum of detected and normalized backscatter, 0 ... 999. Multiplied by scaling factor times 10^4 . At scaling factor 100 the SUM range 0 ... 999 corresponds to integrated backscatter 0 ... 0. srad^{-1} .

CR LF = Carriage Return + Line Feed

LINE 5

mh1_q1_mh2_q2_mh3_q3

where

mh1 (5 characters) = height of the 1st MLH in metres

q1 (5 characters) = quality parameter of the 1st MLH

mh2 (5 characters) = height of the 2nd MLH in metres

q2 (5 characters) = quality parameter of the 2nd MLH

Samples = backscatter resolution and number of samples

1 = MESSAGE 101, 10 m x 770 samples, range 7700 m

2 = MESSAGE 102, 20 m x 385 samples, range 7700 m

3 = MESSAGE 103, 5 m x 1500 samples, range 7500 m

4 = MESSAGE 104, 5 m x 770 samples, range 3850 m

5 = MESSAGE 105, no backscatter profile

0 = MESSAGE 106, extended range, 5 m x 2048 samples, range 10,240 m

STX = Start-of-Text Character

CR LF = Carriage Return + Line Feed

LINE 2

S WA_h1_h2_h3_flags CR LF

where

S (1 character) = message status:

0 = No significant backscatter

1 = One cloud base detected

2 = Two cloud bases detected

3 = Three cloud bases detected

4 = Full obscuration determined but no cloud base detected

5 = Some obscuration detected but determined to be transparent

/ = Raw data input to algorithm missing or suspect

WA (1 character) = Warning or alarm status:

0 = No alarm or warning

W = Warning

A = Alarm

h1 (5 characters) = 1st Height

If detection status is 1, 2 or 3 *h1* = Lowest cloud base reported

If detection status is 4 *h1* = Vertical visibility as calculated

If detection status is 0 or 5 *h1* = "/////"

h2 (5 characters) = 2nd Height

If detection status is 2 or 3 *h2* = Second cloud base reported

If detection status is 4 *h2* = Highest signal received

If detection status is 0, 1 or 5 *h2* = "/////"

h3 (5 characters) = 3rd Height

If detection status is 3 *h3* = Third cloud base reported

If detection status is 0, 1, 2, 4 or 5 *h3* = "/////"

flags (12 characters) = Alarm or warning information.

Description of the most significant alarm word (left word, bits going left to right)	
Bit	Description
8000 XXXX XXXX	Transmitter shut-off
4000 XXXX XXXX	Transmitter failure
2000 XXXX XXXX	Receiver failure
1000 XXXX XXXX	Reserved for future use
0800 XXXX XXXX	Reserved for future use
0400 XXXX XXXX	Memory error
0200 XXXX XXXX	Light path obstruction
0100 XXXX XXXX	Receiver saturation
0080 XXXX XXXX	Reserved for future use
0040 XXXX XXXX	Reserved for future use
0020 XXXX XXXX	Reserved for future use
0010 XXXX XXXX	Reserved for future use
0008 XXXX XXXX	Reserved for future use
0004 XXXX XXXX	Reserved for future use
0002 XXXX XXXX	Reserved for future use
0001 XXXX XXXX	Ceilometer engine board failure

Description of the middle alarm word (middle word, bits going left to right)	
Bit	Description
XXXX 8000 XXXX	Window contamination
XXXX 4000 XXXX	Battery voltage low
XXXX 2000 XXXX	Transmitter expires
XXXX 1000 XXXX	High humidity
XXXX 0800 XXXX	Reserved for future use
XXXX 0400 XXXX	Blower failure
XXXX 0200 XXXX	Reserved for future use
XXXX 0100 XXXX	Humidity sensor failure
XXXX 0080 XXXX	Heater fault
XXXX 0040 XXXX	High background radiance
XXXX 0020 XXXX	Ceilometer engine board failure
XXXX 0010 XXXX	Reserved for future use
XXXX 0008 XXXX	Laser monitor failure
XXXX 0004 XXXX	Receiver warning
XXXX 0002 XXXX	Tilt beyond limit set by user, default 45 degrees
XXXX 0001 XXXX	Reserved for future use

Description of the least significant alarm word (right word, bits going left to right)	
Bit	Description
XXXX XXXX 8000	Blower is on
XXXX XXXX 4000	Blower heater is on
XXXX XXXX 2000	Internal heater is on
XXXX XXXX 1000	Working from battery
XXXX XXXX 0800	Reserved for future use
XXXX XXXX 0400	Self test in progress
XXXX XXXX 0200	Reserved for future use
XXXX XXXX 0100	Reserved for future use
XXXX XXXX 0080	Units are metres if on, else feet
XXXX XXXX 0040	Reserved for future use
XXXX XXXX 0020	Polling mode is on
XXXX XXXX 0010	Reserved for future use
XXXX XXXX 0008	Reserved for future use
XXXX XXXX 0004	Reserved for future use

LINE 5

ETX CRC16 EOT CR LF

where

ETX = End-of-Text character

CRC16 (4 characters) = CRC16-CCITT Checksum

EOT = End-of-Transmission character

CR LF = Carriage Return + Line Feed

MESSAGES 107 - 112, CL31 Message 2**LINE 1**

SOH CL ID OS 2 Samples STX CR LF

where

SOH = Start-of-Heading character

CL = Always CL

ID = A single ASCII character, 0-9, a - z or A - Z, case sensitive. Default ID = 0

OS = Operating system, 100 ... 999

2 = Always 2

Samples = backscatter resolution and number of samples

1 = MESSAGE 107, 10 m x 770 samples, range 7700 m

2 = MESSAGE 108, 20 m x 385 samples, range 7700 m

3 = MESSAGE 109, 5 m x 1500 samples, range 7500 m

4 = MESSAGE 110, 5 m x 770 samples, range 3850 m

5 = MESSAGE 111, no backscatter profile

0 = MESSAGE 112, extended range, 5 m x 2048 samples, range 10,240 m

STX = Start-of-Text Character

CR LF = Carriage Return + Line Feed

LINE 2

S WA_h1_h2_h3_flags CR LF

where

S (1 character) = message status:

- 0 = No significant backscatter
- 1 = One cloud base detected
- 2 = Two cloud bases detected
- 3 = Three cloud bases detected
- 4 = Full obscuration determined but no cloud base detected
- 5 = Some obscuration detected but determined to be transparent
- / = Raw data input to algorithm missing or suspect

WA (1 character) = Warning or alarm status:

- 0 = No alarm or warning
- W = Warning
- A = Alarm

h1 (5 characters) = 1st Height

If detection status is 1, 2 or 3 *h1* = Lowest cloud base reported

If detection status is 4 *h1* = Vertical visibility as calculated

If detection status is 0 or 5 *h1* = "/////"

h2 (5 characters) = 2nd Height

If detection status is 2 or 3 *h2* = Second cloud base reported

If detection status is 4 *h2* = Highest signal received

If detection status is 0, 1 or 5 *h2* = "/////"

h3 (5 characters) = 3rd Height

If detection status is 3 *h3* = Third cloud base reported

If detection status is 0, 1, 2, 4 or 5 *h3* = "/////"

flags (12 characters) = Alarm or warning information.

Same as for messages 101 – 106

CR LF = Carriage Return + Line Feed

LINE 3

__d_h1h1h1__d2_h2h2h2__d3_h3h3h3__d4_h4h4h4__d5_h5h5h5 CR LF

(note spaces)

where

d (1 character) = Data available
 0 to 8 Amount of lowest layer in oktas
 9 Vertical visibility only available
 -1 No sky condition data available
 99 Insufficient data

h1h1h1 (3 characters) = Height of the lowest cloud layer in 10s of metres or 100s of feet

d2 (1 character) = Cloud amount of the 2nd layer in oktas

h2h2h2 (3 characters) = Height of the 2nd cloud layer in 10s of metres or 100s of feet, if no 2nd layer is reported *h2h2h2* = '///'.

d3 (1 character) = Cloud amount of the 3rd layer in oktas

h3h3h3 (3 characters) = Height of the 3rd cloud layer in 10s of metres or 100s of feet, if no 3rd layer is reported *h3h3h3* = '///'.

d4 (1 character) = Cloud amount of the 4th layer in oktas

h4h4h4 (3 characters) = Height of the 4th cloud layer in 10s of metres or 100s of feet, if no 4th layer is reported *h4h4h4* = '///'.

d5 (1 character) = Cloud amount of the 5th layer in oktas

h5h5h5 (3 characters) = Height of the 5th cloud layer in 10s of metres or 100s of feet, if no 5th layer is reported *h5h5h5* = '///'.

CR LF = Carriage Return + Line Feed

LINE 4

scale_res_n_energy_lt_tr_ti_bl_L0112HN15_sum CR LF

where

scale (5 characters) = Scale parameter, %, 0 ... 99999. 100% is typical

res (2 characters) = Backscatter profile resolution in metres.

n (4 characters) = Profile length 385, 770, 1400, or 1500 samples.

energy (3 characters) = Laser pulse energy, %.

lt (3 characters including leading +/-) = Laser temperature, degrees C

tr (3 characters) = Window transmission, %

ti (2 characters) = Total tilt angle, degrees

bl (4 characters) = Background light, millivolts at internal ADC input (0 ... 2500)

"L0112HN15" (9 characters) = Reserved, defaults shown

sum = Sum of detected and normalized backscatter, 0 ... 999. Not used in Operating System 1

CR LF = Carriage Return + Line Feed

NOTE This line is omitted from message 111.

LINE 5

SSSSSSSSSSSSSSSSSSSSSSSSSSSSSSSSSSSS.....(5 x 770 bytes) *CR LF*

The two-way attenuated normalised backscatter profile, see Section 2.1.4.

CR LF = Carriage Return + Line Feed

NOTE This line is omitted from message 111.

LINE 6

ETX CRC16 EOT CR LF

ETX = End-of-Text Character

CRC16 (4 characters) = CRC16 – CCI TT Checksum

EOT = End-of-Transmission character

CR LF = Carriage Return + Line Feed

6.5 CT25K Messages

MESSAGE 113, CT25K Data Message No. 1

LINE 1

SOH CT ID 20 10 STX CR LF

where

SOH = Start-of-Heading character

CT = Always CT

ID (1 character) = Unit number 0 ... 9, A ... Z (capitals only) Default *ID* = 0

20 = Always `20`

10 = Always `10`

STX = Start-of-Text Character

CR LF = Carriage Return + Line Feed

LINE 2

S WA_h1_h2_h3_flags CR LF

where

S (1 character) = message status:

0 = No significant backscatter

1 = One cloud base detected

2 = Two cloud bases detected

3 = Three cloud bases detected

4 = Full obscuration determined but no cloud base detected

5 = Some obscuration detected but determined to be transparent

/ = Raw data input to algorithm missing or suspect

WA (1 character) = Warning or alarm status:

0 = No alarm or warning

W = Warning

A = Alarm

h1 (5 characters) = 1st Height

If detection status is 1, 2 or 3 *h1* = Lowest cloud base reported

If detection status is 4 *h1* = Vertical visibility as calculated

If detection status is 0 or 5 $h1 = "/////"$

$h2$ (5 characters) = 2nd Height

If detection status is 2 or 3 $h2 =$ Second cloud base reported

If detection status is 4 $h2 =$ Height of highest signal detected

If detection status is 0, 1 or 5 $h2 = "/////"$

$h3$ (5 characters) = 3rd Height

If detection status is 3 $h3 =$ Third cloud base reported

If detection status is 0, 1, 2, 4 or 5 $h3 = "/////"$

$flags$ (8 characters) = Alarm or warning information 4-byte hex coded

Description of the most significant alarm word (left side, bits going left to right). Each alarm word is a hexadecimal sum of all the error bits.	
Bit	Description
8000 XXXX	Transmitter shut-off
4000 XXXX	Transmitter failure
2000 XXXX	Receiver failure
1000 XXXX	DSP, voltage or memory failure
0800 XXXX	Reserved for future use
0400 XXXX	Reserved for future use
0200 XXXX	Reserved for future use
0100 XXXX	Reserved for future use
0080 XXXX	Window contaminated
0040 XXXX	Battery low
0020 XXXX	Transmitter expire warning
0010 XXXX	Heater or humidity sensor failure
0008 XXXX	High radiance warning, also XXXX 0004
0004 XXXX	DSP, receiver, or laser monitor failure warning
0002 XXXX	Relative humidity > 85 %
0001 XXXX	Light path obstruction, receiver saturation or receiver failure

Description of the second alarm word (bits going left to right)	
Bit	Description
XXXX 8000	Blower failure
XXXX 4000	Reserved for future use
XXXX 2000	Reserved for future use
XXXX 1000	Reserved for future use
XXXX 0800	Blower on
XXXX 0400	Blower heater on
XXXX 0200	Internal heater on
XXXX 0100	Units metres if on, feet if off.
XXXX 0080	Polling mode on
XXXX 0040	Working from battery
XXXX 0020	Always 0
XXXX 0010	Always 0
XXXX 0008	Tilt beyond limit set by user, default 45 degrees
XXXX 0004	High radiance warning, also 0008 XXXX
XXXX 0002	Reserved for future use
XXXX 0001	Reserved for future use

$CR LF =$ Carriage Return + Line Feed

LINE 3

ETX CR LF

ETX = End-of-Text Character

CR LF = Carriage Return + Line Feed

MESSAGE 114, CT25K Data Message No. 6

LINE 1

SOH CT ID 20 60 STX CR LF

where

SOH = Start-of-Heading character

CT = Always CT

ID (1 character) = Unit number 0 ... 9, A ... Z (capitals only) Default *ID* = 0

20 = always `20`

60 = always `60`

STX = Start-of-Text Character

CR LF = Carriage Return + Line Feed

LINE 2

S WA_h1_h2_h3_flags CR LF

where

S (1 character) = message status:

0 = No significant backscatter

1 = One cloud base detected

2 = Two cloud bases detected

3 = Three cloud bases detected

4 = Full obscuration determined but no cloud base detected

5 = Some obscuration detected but determined to be transparent

/ = Raw data input to algorithm missing or suspect

WA (1 character) = Warning or alarm status:

0 = No alarm or warning

W = Warning

A = Alarm

h1 (5 characters) = 1st Height

If detection status is 1, 2 or 3 *h1* = Lowest cloud base reported

If detection status is 4 *h1* = Vertical visibility as calculated

If detection status is 0 or 5 *h1* = "/////"

h2 (5 characters) = 2nd Height

If detection status is 2 or 3 *h2* = Second cloud base reported

If detection status is 4 $h2$ = Height of highest signal detected
 If detection status is 0, 1 or 5 $h2$ = "////"

$h3$ (5 characters) = 3rd Height
 If detection status is 3 $h3$ = Third cloud base reported
 If detection status is 0, 1, 2, 4 or 5 $h3$ = "////"

$flags$ (8 characters) = Alarm or warning information 4-byte hex coded

As for CT25K message 1.

$CR LF$ = Carriage Return + Line Feed

LINE 3 (SKY CONDITION)

$__d_h1h1h1_d2_h2h2h2_d3_h3h3h3_d4_h4h4h4\ CR\ LF$
 (note spaces)

where

d (1 character) = Data available
 0 to 8 Amount of lowest layer in oktas
 9 Vertical visibility only available
 -1 No sky condition data available
 99 Insufficient data

$h1h1h1$ (3 characters) = Height of the lowest cloud layer in 10s of metres or 100s of feet

$d2$ (1 character) = Cloud amount of the 2nd layer in oktas

$h2h2h2$ (3 characters) = Height of the 2nd cloud layer in 10s of metres or 100s of feet, if no 2nd layer is reported $h2h2h2$ = '///'.

$d3$ (1 character) = Cloud amount of the 3rd layer in oktas

$h3h3h3$ (3 characters) = Height of the 3rd cloud layer in 10s of metres or 100s of feet, if no 3rd layer is reported $h3h3h3$ = '///'.

$d4$ (1 character) = Cloud amount of the 4th layer in oktas

$h4h4h4$ (3 characters) = Height of the 4th cloud layer in 10s of metres or 100s of feet, if no 4th layer is reported $h4h4h4$ = '///'.

$CR LF$ = Carriage Return + Line Feed

LINE 4

ETX CR LF

ETX = End-of-Text Character

CR LF = Carriage Return + Line Feed

7. Maintenance

7.1 General

The CS135 is a robust weather resistant instrument and there is no need for routine maintenance other than cleaning. The instrument performance is monitored and any potential problems are covered by error messages.

7.2 Cleaning

The CS135 window will require cleaning from time to time. The frequency of required cleaning depends on the exposure of the instrument to contaminants such as salt and dust. This will vary depending on the site location. The CS135 is capable of self diagnosing dirty lenses and will indicate in its output when the lenses are contaminated.

In any case we suggest six monthly intervals for locations not prone to contaminants and monthly intervals for those prone to contamination (coastal, roadside or airport use). In some cases more frequent cleaning may be required where there are high levels of contaminants and high dependency on the instrument output.

CAUTION

If the window requires cleaning, it is very important that only a proper lens cloth or lens tissue is used. The use of inappropriate materials to clean the windows can permanently damage or reduce their effectiveness leading to reduced performance.

It is advisable to use an air duster to blow any loose dust and dirt from the window as a first step. Using a lint free lens cloth or lens tissue impregnated with a non-aggressive standard window cleaner. Clean the surface by dragging the cloth across it being careful not to apply excessive pressure.

Excessive pressure may lead to some types of contaminant scratching the window surface. Over time such scratches can lead to reduced sensitivity.

7.3 Removing the Cover

The cover is removed by removing the four screws as shown in Fig 7.1.

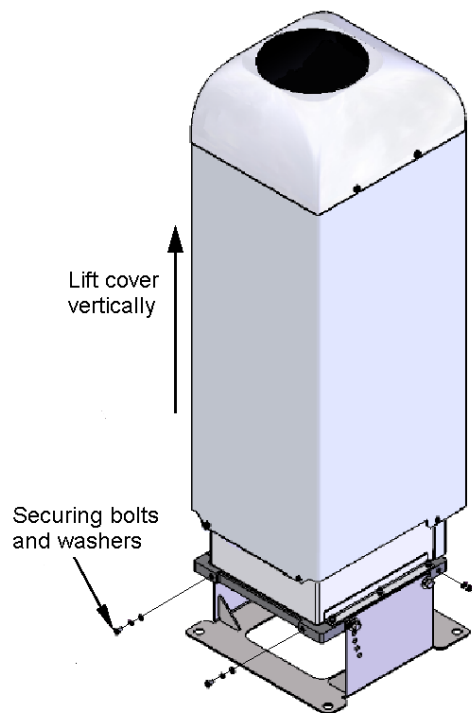

Fig 7.1 Removing the Cover

The cover can then be lifted away.

CAUTION

The cover contains a flying lead used to take power to the hood heater and blower. Be careful not to trap and damage this when lifting the cover clear.

Removing the cover reveals two carrying handles that allow the CS135 to be moved easily.

7.4 Removing the Enclosure Lid

In some circumstances it may be necessary to remove the lid covering the electronics unit, for example to replace desiccant or carry out a hardware reset. This is accomplished by removing the four screws as shown in Fig 7.2.

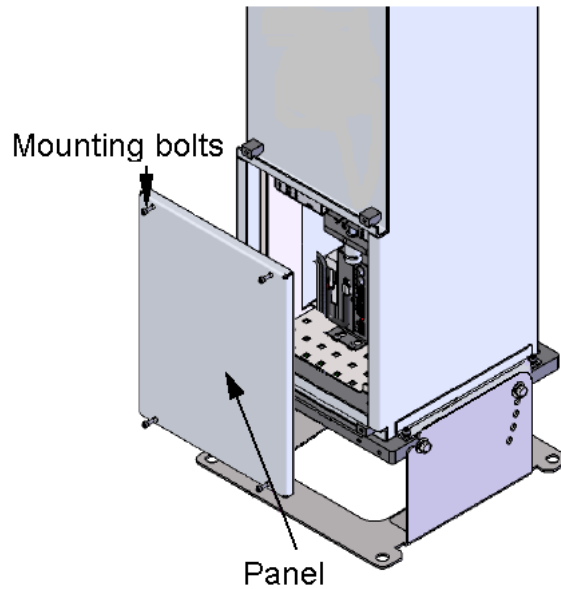

Fig 7.2 Removing the Enclosure Lid

WARNING Opening enclosure lid **MUST** be carried out by a competent person

WARNING Removing the enclosure lid may expose hot surfaces

NOTE The unit will still be powered by the battery even if the mains is disconnected.

NOTE Do not use any grease or oil on any seals including the enclosure lid gasket. The silicone rubber seals used throughout the CS135 can be damaged by some mineral oils.

7.5 Diagnostic LED Indicators Within the Enclosure

Two green LEDs labelled "LASER ON" and "STATUS" are visible on the DSP (see Fig 7.3). Their function is as follows:

"LASER ON" LED:

- Off = laser off
- Flashing = laser fault
- On = laser on

"STATUS" LED

- 1 flash every 10 seconds = OK
- 2 flashes every 10 seconds = warning (possible degraded performance)
- 3 flashes every 10 seconds = alarm (measurements not possible)

The DSP "STATUS" LED duplicates the LED visible through the top window.

There is a red LED on the PSU. It will give 0.5 second flashes as follows:

- 1 flash every 10 seconds = PSU OK
- 2 flashes every 10 seconds = running in battery mode
- 3 flashes every 10 seconds = no communications to the DSP. This takes 60 seconds to start after a communications failure.



Fig 7.3 Diagnostic LED indicators

There is a red LED on the Laser module

- Off = Laser off
- On = Laser on

7.6 Electrical Safety Testing

NOTE

If carrying out insulation tests do not use voltages above 300V RMS as the mains input has devices that effectively short circuit any voltages above this level.

Appendix A. Example CRBasic programs

A.1 Basic Logger program without CRC checking

```
'CR800 Series Datalogger
'Created by Sue Hill 18 July 2013

'CS135 Ceilometer connections
' Blue Tx C1
' White Rx C2
' Green G
'handshake lines shorted

SequentialMode

Const SOH = 1
Const STX = 2
Const ETX = 3
Const EOT = 4

Dim strInCS135 As String * 70
Dim Num_Bytes As Long
Dim strCS135_Message_Status As String * 1
Dim strCS135_Alarm_Status As String * 1

Dim CS135Lines(3) As String * 60
Dim CSLine2_Fields(7) As String * 20

Dim CS135_Unit_of_Measure As String * 3

Public strInformation As String * 100
Public strAlarm As String * 100
Public strError As String * 100

Alias CSLine2_Fields(1)=CS135_MessageAlarm_Status
Alias CSLine2_Fields(2)=CS135_Window_transmission
Alias CSLine2_Fields(3)=CS135_First_Height
Alias CSLine2_Fields(4)=CS135_Second_Height
Alias CSLine2_Fields(5)=CS135_Third_Height
Alias CSLine2_Fields(6)=CS135_Fourth_Height
Alias CSLine2_Fields(7)=CS135_Alarm_Flags

'Define Data Tables

DataTable(Ceilometer,True,-1)
  DataInterval(0,15,sec,10)
  Sample (1,strCS135_Message_Status,String)
  Sample (1,strCS135_Alarm_Status,String)
  Sample (1,CS135_First_Height, ieee4)
  Sample (1,CS135_Second_Height, ieee4)
  Sample (1,CS135_Third_Height, ieee4)
```

```

Sample (1,CS135_Fourth_Height, ieee4)
Sample (1,CS135_Alarm_Flags,String)
EndTable

'Main Program
BeginProg
  ' open the port to the CS135 Ceilometer
  'Assumes default serial settings, if not change baud rate & maybe format
  (2nd & 3rd parameters)
  SerialOpen (Com1,115200,3,0,1000)
  CS135_Unit_of_Measure="ft"

  Scan(15,Sec,1,0)
  SerialInRecord (Com1,strInCS135,SOH,0,EOT,Num_Bytes,01)
  If Num_Bytes > 0 Then
    'Break up message on line feed separator
    SplitStr (CS135Lines,strInCS135,CHR(10),3,5)
    'Break up top line using space as separator
    SplitStr (CSLine2_Fields,CS135Lines(2)," ",7,5)
    'First character is msg status
    strCS135_Message_Status=Left (CS135_MessageAlarm_Status,1)
    'Last character is alarm status
    strCS135_Alarm_Status=Right (CS135_MessageAlarm_Status,1)
    If strCS135_Alarm_Status = "W" Then
      strAlarm = "Warning"
    ElseIf strCS135_Alarm_Status = "A" Then
      strAlarm = "Alarm"
    Else
      strAlarm = "OK"
    EndIf
    Select Case strCS135_Message_Status
    Case "0"
      strInformation = "No significant backscatter"
    Case "1"
      strInformation = "One cloud base detected"
    Case "2"
      strInformation = "Two cloud bases detected"
    Case "3"
      strInformation = "Three cloud bases detected"
    Case "4"
      strInformation = "Four cloud bases detected"
    Case "5"
      strInformation = "Full obscuration determined but no cloud base
detected"
    Case "6"
      strInformation = "Some obscuration detected but determined to be
transparent"
    Case "/"
      strInformation = "Raw data input to algorithm missing or suspect"
    Case Else
      strInformation = "Status of message unknown."
    EndSelect
    strError = ""
  Else
    strError = "COMMS ERROR - No Message received"
  EndIf

  'NOTE to be thorough we should really check message is complete & correct
  by calculating CheckSum and comparing the checksum sent in the message (line
  3), discarding the message if
  'there is no match.

```

```

    CallTable(Ceilometer)
    NextScan
EndProg

```

A.2 Basic Logger program with CRC checking

```

'CR800 Series Datalogger
'Created by Sue Hill 18 July 2013

'CS135 Ceilometer connections
' Blue Tx C1
' White Rx C2
' Green G
'handshake lines shorted

SequentialMode

Const SOH = 1
Const STX = 2
Const ETX = 3
Const EOT = 4

Dim strInCS135 As String * 70
Dim Num_Bytes As Long
Dim strCS135_Message_Status As String * 1
Dim strCS135_Alarm_Status As String * 1
Dim lngCRCCalc As Long
Dim lngCRCMessage As Long
Dim DataOK As Boolean

Dim CS135Lines(3) As String * 60
Dim CSLine2_Fields(7) As String * 20

Dim CS135_Unit_of_Measure As String * 3

Public strInformation As String * 100
Public strAlarm As String * 100
Public strError As String * 100

Alias CSLine2_Fields(1)=CS135_MessageAlarm_Status
Alias CSLine2_Fields(2)=CS135_Window_transmission
Alias CSLine2_Fields(3)=CS135_First_Height
Alias CSLine2_Fields(4)=CS135_Second_Height
Alias CSLine2_Fields(5)=CS135_Third_Height
Alias CSLine2_Fields(6)=CS135_Fourth_Height
Alias CSLine2_Fields(7)=CS135_Alarm_Flags

'Define Data Tables

DataTable(Ceilometer,True,-1)
    DataInterval(0,15,sec,10)
    Sample (1,strCS135_Message_Status,String)
    Sample (1,strCS135_Alarm_Status,String)
    Sample (1,CS135_First_Height,ieee4)

```

```

Sample (1,CS135_Second_Height, ieee4)
Sample (1,CS135_Third_Height, ieee4)
Sample (1,CS135_Fourth_Height, ieee4)
Sample (1,CS135_Alarm_Flags,String)
EndTable

'Main Program
BeginProg
  ' open the port to the CS135 Ceilometer
  'Assumes default serial settings, if not change baud rate & maybe format
  (2nd & 3rd parameters)
  SerialOpen (Com1,115200,3,0,1000)
  CS135_Unit_of_Measure="ft"

  Scan(15,Sec,1,0)
  SerialInRecord (Com1,strInCS135,SOH,0,EOT,Num_Bytes,01)
  If Num_Bytes > 0 Then
    'Break up message on line feed separator
    SplitStr (CS135Lines,strInCS135,CHR(10),3,5)
    'Break up top line using space as separator
    SplitStr (CSLine2_Fields,CS135Lines(2)," ",7,5)
    'First character is msg status
    strCS135_Message_Status=Left (CS135_MessageAlarm_Status,1)
    'Last character is alarm status
    strCS135_Alarm_Status=Right (CS135_MessageAlarm_Status,1)
    If strCS135_Alarm_Status = "W" Then
      strAlarm = "Warning"
    ElseIf strCS135_Alarm_Status = "A" Then
      strAlarm = "Alarm"
    Else
      strAlarm = "OK"
    EndIf
    Select Case strCS135_Message_Status
    Case "0"
      strInformation = "No significant backscatter"
    Case "1"
      strInformation = "One cloud base detected"
    Case "2"
      strInformation = "Two cloud bases detected"
    Case "3"
      strInformation = "Three cloud bases detected"
    Case "4"
      strInformation = "Four cloud bases detected"
    Case "5"
      strInformation = "Full obscuration determined but no cloud base
detected"
    Case "6"
      strInformation = "Some obscuration detected but determined to be
transparent"
    Case "/"
      strInformation = "Raw data input to algorithm missing or suspect"
    Case Else
      strInformation = "Status of message unknown."
    EndSelect
    'Make sure message is complete & correct
    lngCRCCalc = CheckSum (Left(strInCS135,Num_Bytes-4),18,0) XOR &HFFFF
    lngCRCMessage = HexToDec (Mid(strInCS135,59,4))
    DataOK = (Num_Bytes = 62) AND (lngCRCCalc = lngCRCMessage)
    If NOT DataOK Then
      strError = "Data error, messages may be incomplete!"
    Else

```



```
    strError = ""  
  EndIf  
Else  
  strError = "COMMS ERROR - No Message received"  
EndIf  
  CallTable(Ceilometer)  
NextScan  
EndProg
```

Appendix B. Measurement of the attenuated backscatter profile

B.1 Initial measurement

- Pulse the laser and measure the backscatter at optimal gains.
- Derive the impulse response and impulse correct the backscatter signal using the inverse filter derived.
- Remove the residual offset and slope from the impulse corrected backscatter.
- Apply an overlap correction based on the known generic overlap function of the CS135.
- Apply the backscatter calibration constants.
- Remove the laser and electronic artefact signature. This is specific to the individual CS135 and determined during calibration.

B.2 Backscatter onset height detection

- Filter the backscatter with 20 m and 300 m width filters.
- Look for a 1500 m block width where the standard deviation is at a minimum for both the 20 m and 300 m width filtered backscatters.
- Create a detection threshold by multiplying the 20 m and 300 m standard deviations by a constant.
- Find the onset of backscatter height by working from the highest height bin downwards until the backscatter is above one or both of the two detection thresholds.

B.3 Produce attenuated backscatter output message

- Range correct the backscatter to produce the attenuated backscatter.
- Attenuated backscatter (output), calibrated, range corrected but not tilt corrected.
- Smooth with a 20 m width running average.
- A noise gate can be applied based on a multiple of the 20 m detection threshold – this is customer configurable.
- Note the lower height range bins do not gate noise until the backscatter reaches zero. This allows the full extent of mixing layers to be viewed in gating mode.

Appendix C. Cloud height calculation

The scatter profile is inverted (using the Klett inversion technique) and an extinction profile is calculated.

Cloud base heights are identified using two criteria as follows (cloud is detected if either of them is met:

Criterion 1: likely cloud bases are estimated based on increasing slope of the extinction profile of at least 7 m per bin (bin width is 5 m) and an extinction threshold. This threshold is based on an extinction coefficient (EXCO) of 3, equivalent to a horizontal visibility (MOR) of 1,000 m. This results in a number of possible cloud bases at different heights.

Criterion 2: horizontal visibility falls below an average of 4,800 m over 300 m starting at an altitude of 1000 m.

To report a cloud layer above a lower one the scatter coefficient first has to fall below the extinction threshold used for cloud definitions (less a small hysteresis offset). The scatter profile must then again meet the criteria above.

If rain is detected the sensitivity of detection is increased by a factor of 3.

To avoid many very narrow close layers being reported when they have little significance a minimum separation based on WMO reporting intervals is applied. The separation is +/- 30 m below 1,500 m and 300 m above 1,500 m. The lowest cloud height is used. If a thin cloud identified by Criterion 2 above is within +/-150 m of a cloud identified by criterion 1 then the thin cloud is ignored.

Appendix D. Sky condition algorithm description

The CS135 sky condition algorithm follows guidance from ICAO and WMO documents* and is based on 30 minutes of data. For this reason sky condition is not available for 30 minutes after power cycling the sensor, a reboot or changing measurement parameters. The sky condition algorithm is as follows:

Each measured hit comprising the lowest cloud height, (vertical visibility + onset of backscatter) / 2 and a weighting of 1 or 2 is stored in a running half hour buffer.

The weighting is 2 for hits in the last 10 minutes and 1 for hits in the previous 20 minutes.

If >50% of the hits in the latest 10 minutes are vertical visibility then the vertical visibility averaged over the last 10 minutes is reported. Only hits below the vertical visibility height limit set are used.

The buffer is sorted in height order and hits combined into bins with the following widths.

Height	Bin width
0 - 5,000ft	100ft
5,000 – 15,000ft	200ft
15,000ft – 33,000ft	500ft

For each bin a mean height is calculated by the following:

$$H_i = \sum(h_i w_i) / \sum(w_i)$$

Where w_i is the weight (1 or 2) of the hit with height h_i

Bins are then reduced. A distance (D) between adjacent bins is calculated by the following equation:

$$D = N_i N_j (H_i - H_j)^2 / (N_i + N_j)$$

Where N_i and N_j are the sum of hits of each bin and H_i and H_j the respective heights.

Find the pair with the minimum distance D and combine into one bin with the height of the lowest and number of hits of the combined total.

This process is repeated until 5 or less bins remain. These are now taken as cloud layers.

Finally if cloud layers are closer than the distances below then they are merged with the height of the lowest and combined total number of hits.

Height range	Distance (D)
Height ≤ 300m (1,000ft)	≤ 90m (300ft)
300m < Height ≤ 900m (1,000ft < Height ≤ 3,000ft)	≤ 120m (400ft)
900m < Height ≤ 1,500m (3,000ft < Height ≤ 5,000ft)	≤ 180m (600ft)
1,500m < Height ≤ 2,400m (5,000ft < Height ≤ 8,000ft)	≤ 300m (1,000ft)
Height > 2,400m (8,000ft)	≤ 480m (1,600ft)

Weights per layer are used to calculate number of oktas per layer.

If the total possible is W_{max} then the cover is $(W_i/W_{max}) \times 8$.

Cloud amounts are rounded up to the next highest whole oktas.

For layers above the lowest this is based on the maximum possible weights. If the lower layers have W_1 hits and the next layer has W_2 hits then the cover of the higher layer is given by:

$$(W_2/(W_{max}-W_1)) \times 8$$

For example, taking weighting into account, if lower layers of cloud only allow 4/8 of clear sky above and the cover is 2/8 out of those 4/8 then the layer above is taken as 4/8.

Finally only layers meeting the following criteria are reported:

Layer 1 ≥ 8/33 oktas

Layer 2 ≥ 3 oktas

Layer 3 ≥ 5 oktas

Layer 4 ≥ 7 oktas

Layer 5 ≥ 7 oktas

Any layer > $(8 - 8/33)$ oktas is reported as 8 oktas

*ICAO 9837 Manual on Automatic Meteorological Observing Systems at Aerodromes.

WMO – No. 306 Manual on Codes

Campbell Scientific Companies

Campbell Scientific, Inc.

815 West 1800 North
Logan, Utah 84321
UNITED STATES

www.campbellsci.com • info@campbellsci.com

Campbell Scientific Canada Corp.

14532 – 131 Avenue NW
Edmonton AB T5L 4X4
CANADA

www.campbellsci.ca • dataloggers@campbellsci.ca

Campbell Scientific Africa Pty. Ltd.

PO Box 2450
Somerset West 7129
SOUTH AFRICA

www.campbellsci.co.za • cleroux@csafrica.co.za

Campbell Scientific Centro Caribe S.A.

300 N Cementerio, Edificio Breller
Santo Domingo, Heredia 40305
COSTA RICA

www.campbellsci.cc • info@campbellsci.cc

Campbell Scientific Southeast Asia Co., Ltd.

877/22 Nirvana@Work, Rama 9 Road
Suan Luang Subdistrict, Suan Luang District
Bangkok 10250
THAILAND

www.campbellsci.asia • info@campbellsci.asia

Campbell Scientific Ltd.

Campbell Park
80 Hathern Road
Shepshed, Loughborough LE12 9GX
UNITED KINGDOM

www.campbellsci.co.uk • sales@campbellsci.co.uk

Campbell Scientific Australia Pty. Ltd.

PO Box 8108
Garbutt Post Shop QLD 4814
AUSTRALIA

www.campbellsci.com.au • info@campbellsci.com.au

Campbell Scientific Ltd.

3 Avenue de la Division Leclerc
92160 ANTONY
FRANCE

www.campbellsci.fr • info@campbellsci.fr

Campbell Scientific (Beijing) Co., Ltd.

8B16, Floor 8 Tower B, Hanwei Plaza
7 Guanghua Road
Chaoyang, Beijing 100004
P.R. CHINA

www.campbellsci.com • info@campbellsci.com.cn

Campbell Scientific Ltd.

Fahrenheitstraße 13
28359 Bremen
GERMANY

www.campbellsci.de • info@campbellsci.de

Campbell Scientific do Brasil Ltda.

Rua Apinagés, nbr. 2018 – Perdizes
CEP: 01258-00 – São Paulo – SP
BRASIL

www.campbellsci.com.br • vendas@campbellsci.com.br

Campbell Scientific Spain, S. L.

Avda. Pompeu Fabra 7-9, local 1
08024 Barcelona
SPAIN

www.campbellsci.es • info@campbellsci.es

Please visit www.campbellsci.com to obtain contact information for your local US or international representative.