

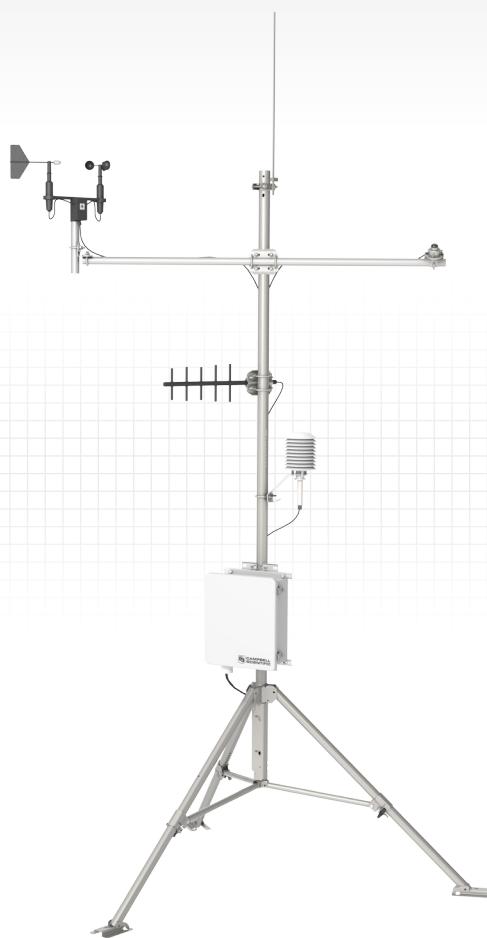

CM110, CM115, CM120

Stainless-Steel Instrument Tripods



Strong, Lightweight

Easy to set up and take down

Overview

Campbell Scientific's CM110, CM115, and CM120 tripods support the attachment of sensors, mounts, solar panels, and environmental enclosures. Measurement heights are 10 ft (3 m) for the CM110, 15 ft (4.6 m) for the CM115, and 20 ft (6.1 m) for the CM120.

Constructed from stainless steel, these tripods are easier to transport to remote locations. They can be deployed in uneven terrain and at varying heights. To facilitate sensor attachment, their masts pivot at the leg junction.

Benefits and Features

- › Strong and lightweight
- › Most joints are locked with pins that are simple to insert and remove
- › Individually-adjustable legs allow installation over uneven terrain
- › Includes grounding kit, UV -resistant cable ties, and six spikes for the tripod feet are included with the tripod
- › CM115 and CM120 tripods include a guy kit; an optional guy kit is offered for the CM110
- › Most Campbell Scientific enclosures can attach to either the tripod's mast (top photo) or leg base (photo at right).



More info: +61 (0)7 4401 7700

www.campbellsci.com.au/tripods



Guy Duckbill Anchor Kits

Two duckbill anchor kits are offered for securing the guy wires (see Ordering Information). Duckbill anchors are not required to use the guy-wire kits. Without them, the guy wires are run from the mast to the feet of the tripod. Duckbill anchors are recommended for areas subjected to higher winds. They allow the guy wires to be anchored at points beyond the feet, thereby increasing the rating of the tripod for higher winds.

The 19282 Guy Duckbill Standard Anchor Kit is for standard soils. The 25699 Guy Duckbill Heavy Duty Anchor Kit is for aggressive soils. Aggressive soils have:

- Resistivity of less than 3000 ohm-cm
- pH of less than 5
- Chloride of greater than 1000 ppm
- Sulfate of greater than 500 ppm
- Poor aeration

Ordering Information (see note 1)

Tripods

- CM110** 3 m (10 ft) lightweight tripod with grounding kit.
- CM115** 5 m (15 ft) lightweight tripod with grounding kit and guy kit.
- CM120** 6 m (20 ft) lightweight tripod with grounding kit and guy kit.

Accessories

- 19192** Carrying Tote Bag that holds one lightweight tripod.
- 19239** Guy Kit for the CM110 tripod
- 19241** Tripod Extension Kit that increases the height of a CM110 or CM115 mast by 1.6 m (5 ft). Maximum measurement height provided by the 19241 is 6 m (20 ft); see note 2.
- 19282** Guy Duckbill Standard Anchor Kit, 1100 lb. Not recommended for aggressive or rocky soils. Use the 25699 heavy duty anchor kit for aggressive soils (see below).
- 25699** Guy Duckbill Heavy Duty Anchor Kit, 3000 lb. Recommended for aggressive soils.
- CM216** Sensor Mounting Kit for Top of CM110-series Tripod Mast

Specifications

	CM110	CM115	CM120
Height with Mast Insert	3.1 m (10.5 ft)	4.5 m (15.2 ft)	6 m (20 ft)
Weight	15 kg (34 lb)	18 kg (40 lb)	21 kg (46 lb)
Base Diameter with Legs Extended	2 m (10.5 ft)		
Dimensions of Collapsed Tripod	15 x 15 x 145 cm (6 x 6 x 57 in.)		
Vertical Load Limit	45 kg (100 lb)		
Number of Mast Sections	1	2	3
Mast Length	1.4 m (4.6 ft)	2.8 m (9.3 ft)	4.3 m (14 ft)
Mast Length with Insert	2.6 m (8.6 ft)	4.1 m (13.3 ft)	5.5 m (18 ft)
Mast Outer Diameter	4.8 cm (1.9 in.)		
Insert Outer Diameter	4.45 cm (1.75 in.)		
Mounting Hole in Tripod Foot	0.75 in diameter hole for ground stake		
Tote Bag Dimensions	152 cm (60 in.) length, 20 cm (8 in.) diameter		
Maximum Slope Angle	10.6° degrees (18% gradient) when one leg is oriented downhill		
Wind Load Recommendations— Sustained Wind (see note 3)	75 mph (unguyed), 80 mph (guyed at feet)	56.25 mph (guyed at feet), 75 mph (guyed at 60°)	42.25 mph (guyed at feet) 65 mph (guyed at 60°)
Wind Load Recommendations— Gust Tolerance (see note 3)	95 mph (unguyed), 100 mph (guyed at feet)	71.25 mph (guyed at feet), 95 mph (guyed at 60°)	55.25 mph (guyed at feet) 85 mph (guyed at 60°)

Notes:

1. See the Crossarms, Solar Radiation Sensor Mounts, Radiation Shields, and General Mounts brochures for mounting options.
2. The 19241 extension kit is not recommended for the CM120. Customers who require measurement heights greater than 6 m (20 ft) should use a UT30 tower.
3. The Wind Load Recommendations for the CS115 and CS120 assume the guy wire anchors are able to hold at least 1.8 kN (400 lbf).