

INSTRUCTION MANUAL



Tripod Installation Manual *Models CM110, CM115, CM120*

Revision: 10/16



Copyright © 2005-2016
Campbell Scientific, Inc.

WARRANTY AND ASSISTANCE

This equipment is warranted by CAMPBELL SCIENTIFIC (CANADA) CORP. ("CSC") to be free from defects in materials and workmanship under normal use and service for **twelve (12) months** from date of shipment unless specified otherwise. ***** **Batteries are not warranted.** ***** CSC's obligation under this warranty is limited to repairing or replacing (at CSC's option) defective products. The customer shall assume all costs of removing, reinstalling, and shipping defective products to CSC. CSC will return such products by surface carrier prepaid. This warranty shall not apply to any CSC products which have been subjected to modification, misuse, neglect, accidents of nature, or shipping damage. This warranty is in lieu of all other warranties, expressed or implied, including warranties of merchantability or fitness for a particular purpose. CSC is not liable for special, indirect, incidental, or consequential damages.

Products may not be returned without prior authorization. To obtain a Return Merchandise Authorization (RMA), contact CAMPBELL SCIENTIFIC (CANADA) CORP., at (780) 454-2505. An RMA number will be issued in order to facilitate Repair Personnel in identifying an instrument upon arrival. Please write this number clearly on the outside of the shipping container. Include description of symptoms and all pertinent details.

CAMPBELL SCIENTIFIC (CANADA) CORP. does not accept collect calls.

Non-warranty products returned for repair should be accompanied by a purchase order to cover repair costs.



Campbell Scientific (Canada) Corp.
14532 131 Avenue NW | Edmonton AB T5L 4X4
780.454.2505 | fax 780.454.2655 | campbellsci.ca

Assistance

Products may not be returned without prior authorization. The following contact information is for Canadian and international clients residing in countries served by Campbell Scientific (Canada) Corp. directly. Affiliate companies handle repairs for clients within their territories. Please visit www.campbellsci.ca to determine which Campbell Scientific company serves your country.

To obtain a Returned Materials Authorization (RMA), contact CAMPBELL SCIENTIFIC (CANADA) CORP., phone (780) 454-2505. After a measurement consultant determines the nature of the problem, an RMA number will be issued. Please write this number clearly on the outside of the shipping container. Campbell Scientific's shipping address is:

CAMPBELL SCIENTIFIC (CANADA) CORP.

RMA# _____
14532 131 Avenue NW
Edmonton, Alberta T5L 4X4
Canada

For all returns, the client must fill out a "Statement of Product Cleanliness and Decontamination" form and comply with the requirements specified in it. The form is available from our web site at www.campbellsci.ca/repair. A completed form must be either emailed to repair@campbellsci.ca or faxed to (780) 454-2655. Campbell Scientific (Canada) Corp. is unable to process any returns until we receive this form. If the form is not received within three days of product receipt or is incomplete, the product will be returned to the client at the client's expense. Campbell Scientific (Canada) Corp. reserves the right to refuse service on products that were exposed to contaminants that may cause health or safety concerns for our employees.

Precautions

DANGER — MANY HAZARDS ARE ASSOCIATED WITH INSTALLING, USING, MAINTAINING, AND WORKING ON OR AROUND TRIPODS, TOWERS, AND ANY ATTACHMENTS TO TRIPODS AND TOWERS SUCH AS SENSORS, CROSSARMS, ENCLOSURES, ANTENNAS, ETC. FAILURE TO PROPERLY AND COMPLETELY ASSEMBLE, INSTALL, OPERATE, USE, AND MAINTAIN TRIPODS, TOWERS, AND ATTACHMENTS, AND FAILURE TO HEED WARNINGS, INCREASES THE RISK OF DEATH, ACCIDENT, SERIOUS INJURY, PROPERTY DAMAGE, AND PRODUCT FAILURE. TAKE ALL REASONABLE PRECAUTIONS TO AVOID THESE HAZARDS. CHECK WITH YOUR ORGANIZATION'S SAFETY COORDINATOR (OR POLICY) FOR PROCEDURES AND REQUIRED PROTECTIVE EQUIPMENT PRIOR TO PERFORMING ANY WORK.

Use tripods, towers, and attachments to tripods and towers only for purposes for which they are designed. Do not exceed design limits. Be familiar and comply with all instructions provided in product manuals. Manuals are available at www.campbellsci.ca or by telephoning (780) 454-2505 (Canada). You are responsible for conformance with governing codes and regulations, including safety regulations, and the integrity and location of structures or land to which towers, tripods, and any attachments are attached. Installation sites should be evaluated and approved by a qualified personnel (e.g. engineer). If questions or concerns arise regarding installation, use, or maintenance of tripods, towers, attachments, or electrical connections, consult with a licensed and qualified engineer or electrician.

General

- Prior to performing site or installation work, obtain required approvals and permits.
- Use only qualified personnel for installation, use, and maintenance of tripods and towers, and any attachments to tripods and towers. The use of licensed and qualified contractors is highly recommended.
- Read all applicable instructions carefully and understand procedures thoroughly before beginning work.
- Wear a **hardhat** and **eye protection**, and take **other appropriate safety precautions** while working on or around tripods and towers.
- **Do not climb** tripods or towers at any time, and prohibit climbing by other persons. Take reasonable precautions to secure tripod and tower sites from trespassers.
- Use only manufacturer recommended parts, materials, and tools.

Utility and Electrical

- **You can be killed** or sustain serious bodily injury if the tripod, tower, or attachments you are installing, constructing, using, or maintaining, or a tool, stake, or anchor, come in **contact with overhead or underground utility lines**.
- Maintain a distance of at least one-and-one-half times structure height, 6 meters (20 feet), or the distance required by applicable law, **whichever is greater**, between overhead utility lines and the structure (tripod, tower, attachments, or tools).
- Prior to performing site or installation work, inform all utility companies and have all underground utilities marked.
- Comply with all electrical codes. Electrical equipment and related grounding devices should be installed by a licensed and qualified electrician.

Elevated Work and Weather

- Exercise extreme caution when performing elevated work.
- Use appropriate equipment and safety practices.
- During installation and maintenance, keep tower and tripod sites clear of un-trained or non-essential personnel. Take precautions to prevent elevated tools and objects from dropping.
- Do not perform any work in inclement weather, including wind, rain, snow, lightning, etc.

Maintenance

- Periodically (at least yearly) check for wear and damage, including corrosion, stress cracks, frayed cables, loose cable clamps, cable tightness, etc. and take necessary corrective actions.
- Periodically (at least yearly) check electrical ground connections.

WHILE EVERY ATTEMPT IS MADE TO EMBODY THE HIGHEST DEGREE OF SAFETY IN ALL CAMPBELL SCIENTIFIC PRODUCTS, THE CLIENT ASSUMES ALL RISK FROM ANY INJURY RESULTING FROM IMPROPER INSTALLATION, USE, OR MAINTENANCE OF TRIPODS, TOWERS, OR ATTACHMENTS TO TRIPODS AND TOWERS SUCH AS SENSORS, CROSSARMS, ENCLOSURES, ANTENNAS, ETC.

PLEASE READ FIRST

About this manual

Please note that this manual was originally produced by Campbell Scientific Inc. (CSI) primarily for the US market. Some spellings, weights and measures may reflect this origin.

Some useful conversion factors:

Area:	1 in ² (square inch) = 645 mm ²
Length:	1 in. (inch) = 25.4 mm
	1 ft (foot) = 304.8 mm
	1 yard = 0.914 m
	1 mile = 1.609 km
Mass:	1 oz. (ounce) = 28.35 g
	1 lb (pound weight) = 0.454 kg
Pressure:	1 psi (lb/in ²) = 68.95 mb
Volume:	1 US gallon = 3.785 litres

In addition, part ordering numbers may vary. For example, the CABLE5CBL is a CSI part number and known as a FIN5COND at Campbell Scientific Canada (CSC). CSC Technical Support will be pleased to assist with any questions.

About sensor wiring

Please note that certain sensor configurations may require a user supplied jumper wire. It is recommended to review the sensor configuration requirements for your application and supply the jumper wire is necessary.

Table of Contents

PDF viewers: These page numbers refer to the printed version of this document. Use the PDF reader bookmarks tab for links to specific sections.

1. Introduction	1
2. Precautions	2
3. Initial Inspection.....	2
3.1 Inspect Packaging	2
3.2 Tripod Components.....	2
3.3 Tools List (for tripod, mast and crossarm)	3
4. Overview	3
5. Specifications.....	4
6. Installation	5
6.1 Tripod Installation.....	5
6.1.1 Tripod Base.....	5
6.1.2 Mast	6
6.1.3 Installing the Guy Kit.....	10
6.1.3.1 Guy Duckbill Anchor Kits	12
6.1.3.2 Lowering Mast after Attaching Guy Wires	14
6.1.4 Staking the Tripod Feet.....	15
6.1.5 Tripod Grounding	16
6.1.6 Crossarm Attachment.....	18
6.1.7 Enclosure Attachment.....	18
6.1.7.1 Enclosure Mounting to Tripod Mast	18
6.1.7.2 Enclosure Mounting to Tripod Leg	19
6.2 Mounting Brackets.....	21
6.2.1 CM210 Crossarm Mounting Kit	21
6.2.2 CM216 Mast Mounting Kit	22
6.2.3 CM220 Right Angle Mounting Kit.....	23
6.2.4 CMB200 Crossarm Brace Kit.....	24
6.2.4.1 Overview	24
6.2.4.2 Components.....	24
6.2.4.3 Assembly.....	25
6.2.5 CM225 and 18098 Pyranometer Mounting Stand.....	27
6.2.6 CM230 and CM230XL Adjustable Angle Mounting Kits.....	28
6.2.7 CM235 Magnetic Mounting Stand	29
6.2.8 RM Young Multi-Plate Radiation Shields	30

Appendix

A. Tripod Tote Bag	A-1
---------------------------------	------------

Figures

1-1.	Typical tripod-based weather station.....	1
3-1.	Tripod components.....	2
4-1.	CM110 tripod with optional guy wires (guy wires included with CM115 and CM120).....	3
5-1.	60-degree guy angle.....	5
6-1.	Tripod leg, slide collar components.....	6
6-2.	Tripod mast and insert.....	7
6-3.	Mast attachment to tripod base.....	8
6-4.	Mast lock bracket.....	9
6-5.	Guy collar.....	10
6-6.	Guy cinch and lever arm.....	11
6-7.	Mechanical drawing of guy hook and case.....	12
6-8.	Duckbill guy anchor.....	13
6-9.	Top view and guy anchor layout.....	14
6-10.	Staking the tripod feet.....	15
6-11.	Ground rod and clamp.....	16
6-12.	Lightning rod and tripod ground lug.....	17
6-13.	CM200-series crossarm.....	18
6-14.	Enclosure with the –MM bracket.....	19
6-15.	Enclosure with the –LM bracket.....	20
6-16.	CM210 Crossarm Mounting Kit (shown with user-supplied pipe) ...	21
6-17.	CM216 Mast Mounting Kit.....	22
6-18.	CM220 Right Angle Mounting Kit.....	23
6-19.	CMB200 Crossarm Brace Kit.....	24
6-20.	CMB200 components.....	25
6-21.	Bracket selection.....	26
6-22.	CM225 Pyranometer Mounting Stand.....	27
6-23.	CM230 and CM230XL Adjustable Angle Mounting Kits.....	28
6-24.	CM235 Magnetic Mounting Stand.....	29
6-25.	RM Young Multi-Plate Radiation Shield.....	30

Table

6-1.	Bracket Requirements.....	26
------	---------------------------	----

Tripod Installation Manual

Models CM110, CM115, CM120

1. Introduction

The CM110 (10 ft), CM115 (15 ft), and CM120 (20 ft) tripods are corrosion-resistant stainless steel instrument mounts that support the attachment of sensors, solar panels, and environmental enclosures. A guy kit is included with the CM115 and CM120 models, and is an option for the CM110. A durable Tripod Tote Bag is available as an option.

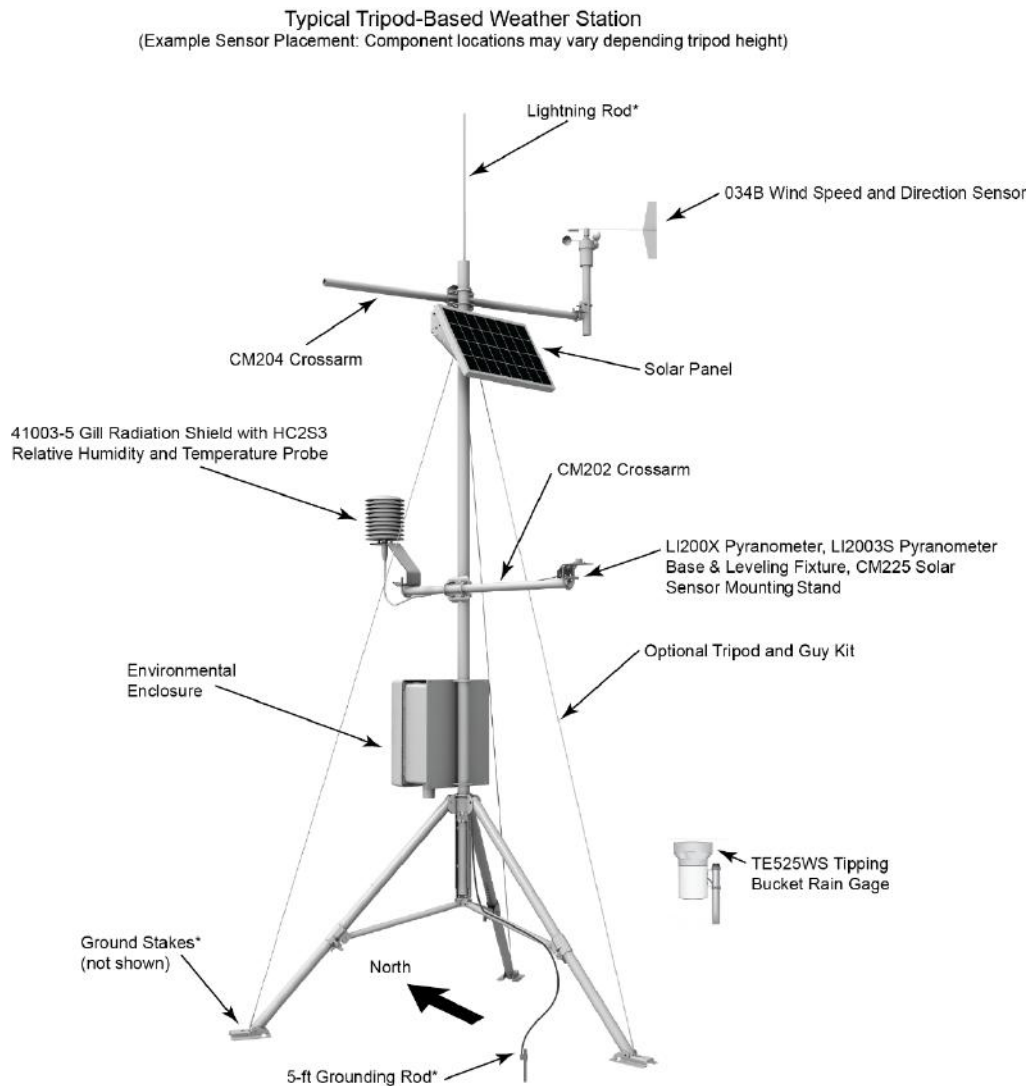

* Included with tripod purchase. Other items purchased separately; alternate sensors available.

FIGURE 1-1. Typical tripod-based weather station

2. Precautions

- READ AND UNDERSTAND the *Safety* section at the front of this manual.
- WARNING — Ensure structural integrity during setup and weather extremes to minimize the chance of damaging the tripod or instruments. Read all instructions carefully. Once the tripod is in full vertical position, securely fasten it to the ground using ground spikes.
- WARNING — For installations where soil structure is questionable or the tripod may experience high wind loads, concrete footings for the tripod feet and guy anchors should be considered.

3. Initial Inspection

3.1 Inspect Packaging

Upon receiving the tripod, inspect the packaging and contents for damage. Claims for shipping damage must be filed with the shipping company.

Locate the packing slip for the order and compare the items listed on the packing slip to the items that were actually shipped. Report any discrepancies to Campbell Scientific.

3.2 Tripod Components

FIGURE 3-1 shows the tripod components packaged for shipment. The tripod base is packaged with the mast, ground rod, lightning rod, and (6) stakes. The ground rod clamp, lightning rod, and ground wires are enclosed in a bag. The guy kit (optional for the CM110), and tripod tote bag (optional) are packaged separately. The CM115 and CM120 tripods include additional mast sections. A diagram showing how to stow the components inside the tote bag is shown in Appendix A, *Tripod Tote Bag* (p. A-1).



FIGURE 3-1. Tripod components

3.3 Tools List (for tripod, mast and crossarm)

- 1/2-in and 7/16-in open end wrenches
- adjustable wrench
- socket wrench with 1/2-in and 7/16-in deep sockets (optional)
- Phillips head screwdriver (medium)
- Straight bit screwdriver (large)
- 12-in torpedo level
- side-cut pliers
- pencil
- tape measure
- compass and site declination angle
- shovel
- sledgehammer (for driving ground rod and stakes)
- step ladder

4. Overview

The tripod (FIGURE 4-1) is constructed from galvanized steel, with individually adjustable legs that allow installation over uneven terrain.

The tripod includes lightning and ground rods, ground cables, UV resistant cable ties, and stakes for securing the tripod feet to the ground. A guy kit is included (optional for the CM110) for sites that experience high wind speeds (see Section 5, *Specifications* (p. 4)). Instrument enclosures can be purchased with mounting brackets that attach to either the mast or leg section as shown in Section 6.1.7, *Enclosure Attachment* (p. 18).

The tripod can be used for a variety of applications. For meteorological stations, sensors are mounted to the tripod using mounting brackets appropriate for the model of sensor. For non-meteorological applications, the tripod can be used to mount instrument enclosures, solar panels, junction boxes, or antennas.



FIGURE 4-1. CM110 tripod with optional guy wires (guy wires included with CM115 and CM120)

5. Specifications

	<u>CM110</u>	<u>CM115</u>	<u>CM120</u>
Height w/mast insert:	3.1 m (10.5 ft)	4.5 m (15.2 ft)	6 m (20 ft)
Weight:	15 kg (34 lb)	18 kg (40 lb)	21 kg (46 lb)
Base diameter w/legs extended:	2 m (7 ft)	2 m (7 ft)	2 m (7 ft)
Dimensions of collapsed tripod:	15 x 15 x 145 cm (6 x 6 x 57 in)	15 x 15 x 145 cm (6 x 6 x 57 in)	15 x 15 x 145 cm (6 x 6 x 57 in)
Vertical load limit:	45 kg (100 lb)	45 kg (100 lb)	45 kg (100 lb)
Mast description			
Number of sections:	1	2	3
Length:	1.4 m (4.6 ft)	2.8 m (9.3 ft)	4.3 m (14.0 ft)
Length w/insert:	2.6 m (8.6 ft)	4.1 m (13.3 ft)	5.5 m (18.0 ft)
OD:	4.8 cm (1.9 in)	4.8 cm (1.9 in)	4.8 cm (1.9 in)
Insert OD:	4.45 cm (1.75 in)	4.45 cm (1.75 in)	4.45 cm (1.75 in)
Mounting hole in tripod foot:	0.75 in diameter hole for user-supplied 0.5 in J-bolts	0.75 in diameter hole for user-supplied 0.5 in J-bolts	0.75 in diameter hole for user-supplied 0.5 in J-bolts
Wind load recommendations¹			
Sustained wind (mph):	75 (unguyed) 80 (guyed at feet)	56.25 (guyed at feet) 75 (guyed at 60°)	42.25 (guyed at feet) 65 (guyed at 60°)
Gust tolerance (mph):	95 (unguyed) 100 (guyed at feet)	71.25 (guyed at feet) 95 (guyed at 60°)	55.25 (guyed at feet) 85 (guyed at 60°)
Tote bag dimensions:	20 cm (8 in) diameter, 152 cm (60 in) length	20 cm (8 in) diameter, 152 cm (60 in) length	20 cm (8 in) diameter, 152 cm (60 in) length

¹The wind load recommendations for the CM115 and CM120 assume the guy wire anchors are able to hold at least 1.8 kN (400 lbf).

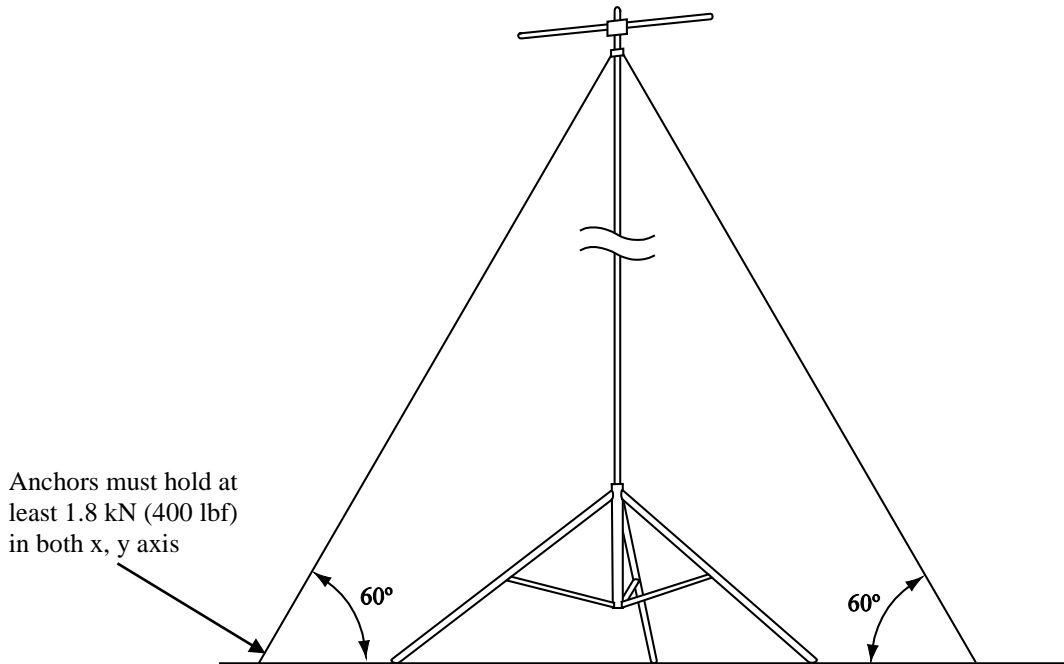

FIGURE 5-1. 60-degree guy angle

6. Installation

6.1 Tripod Installation

6.1.1 Tripod Base

WARNING

Tripod installation near power lines is dangerous. The minimum safe recommended distance from overhead power lines is two times the height of the tripod and mast combined. Contact local utility providers to locate any buried utilities prior to installation.

All three models of tripods use the same tripod base. Each leg is adjustable, allowing the tripod to be adjusted for non-level terrain.

Prepare the area where the tripod will be installed. The tripod requires an area approximately 7 feet in diameter. Natural vegetation and the ground surface should be disturbed as little as possible, but brush and tall weeds should be removed.

Stand the tripod base on end, and rotate the feet perpendicular to the legs. Each leg has a slide collar and T-knob with a spring loaded pin that locks into holes located on the underside of the leg as shown in FIGURE 6-1.

Extend each leg until the pin engages in a hole (depress the tab to disengage the pin from a hole). With the legs extended, orient the tripod so that the open channel of the tripod base faces north. The tripod is typically plumbed after the mast has been installed, as described in Section 6.1.2, *Mast* (p. 6).

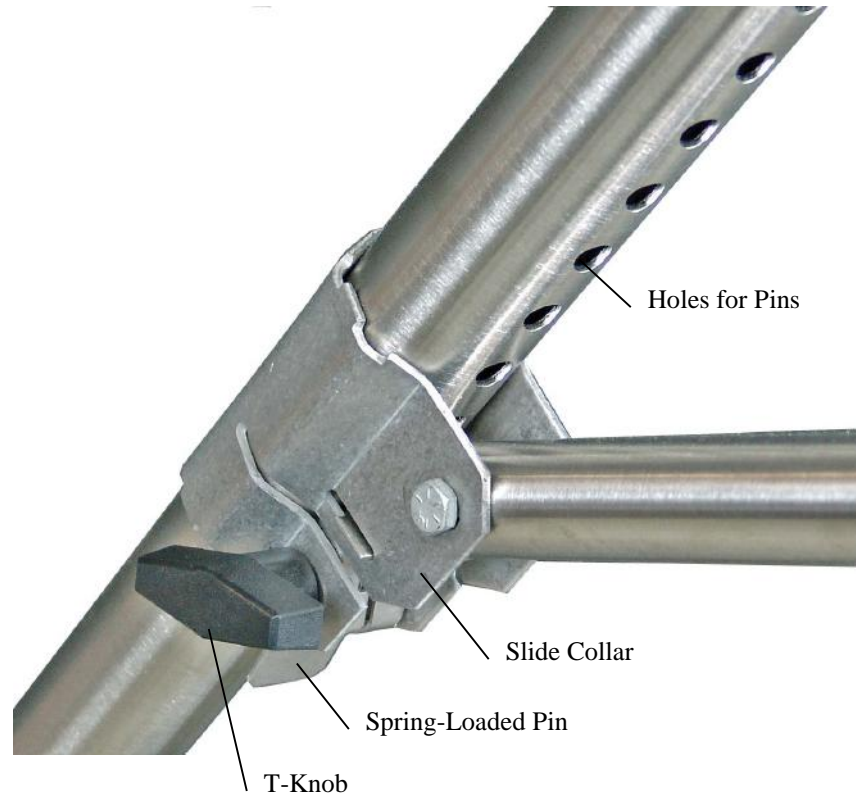

FIGURE 6-1. Tripod leg, slide collar components

6.1.2 Mast

The CM110, CM115, and CM120 tripods have one, two, or three mast sections respectively. The top mast section has a 56-in long insert with a series of holes that can be extended to lengthen the mast (FIGURE 6-2). Remove the bolt that secures the insert to the inside of the mast, and slide the insert out from the mast to see the different hole locations. Slide the insert back into the mast, aligning the appropriate holes of the insert with holes in the mast, and replace the bolt.

Additional 56-in mast section(s) included with the CM115 and CM120 tripods have a 16-in long insert that is used to connect the mast sections together. Remove the bolt that secures the insert to the inside of the mast and extend the insert 8 in; align the holes and replace the bolt. Attach additional mast sections by sliding the bottom of the next mast section over the insert of a lower section, aligning the holes and installing the bolt. Typically the bottom mast section is attached to the tripod and tilted down to a horizontal position, and the additional mast sections bolted to the bottom section.



FIGURE 6-2. Tripod mast and insert

The tripod base has two sets of right-angled holes for attaching the mast; typically the lower set is used (FIGURE 6-3A). The mast is attached to the base with a pin, and secured in the upright position with a locking bracket. Both the pin and the locking bracket are secured with a lanyard.

To attach the lower mast section, hold the mast upright and align the hole in the bottom of the mast with the holes in the tripod base. Insert the pin through the holes, and rotate the wire retainer over the end of the pin as shown in FIGURE 6-3B. The pin should be seated in the bottom of the hole when the mast is upright. Lift the mast up so that the pin is in the upper end of the hole to allow the mast to be tilted down to a horizontal position.

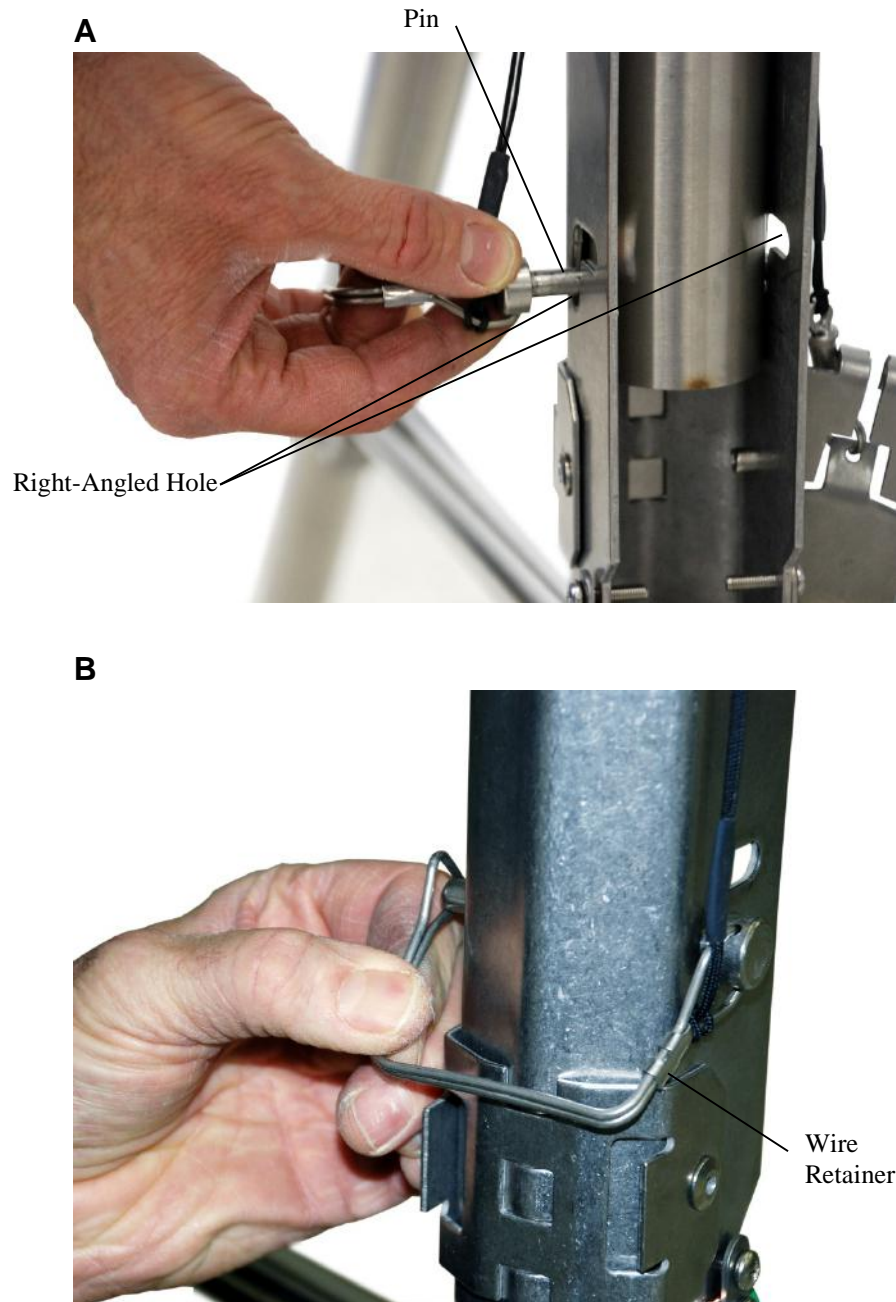

FIGURE 6-3. Mast attachment to tripod base

Secure the mast in the upright position by installing the locking bracket (FIGURE 6-4A). Insert the top of the bracket into the notches in the tripod base, and using both thumbs, press the bracket into the body of the base until the lower tabs lock into position (FIGURE 6-4B). Install the pin as shown in FIGURE 6-4C. To remove the bracket, remove the pin and squeeze the lower part of the bracket to disengage the tabs, then rotate the bracket out and up.

Plumb the tripod by adjusting the northeast and south facing legs. With a level on the east side of the mast, adjust the northeast leg for plumb. With the level on the south side of the mast, adjust the south leg for plumb.

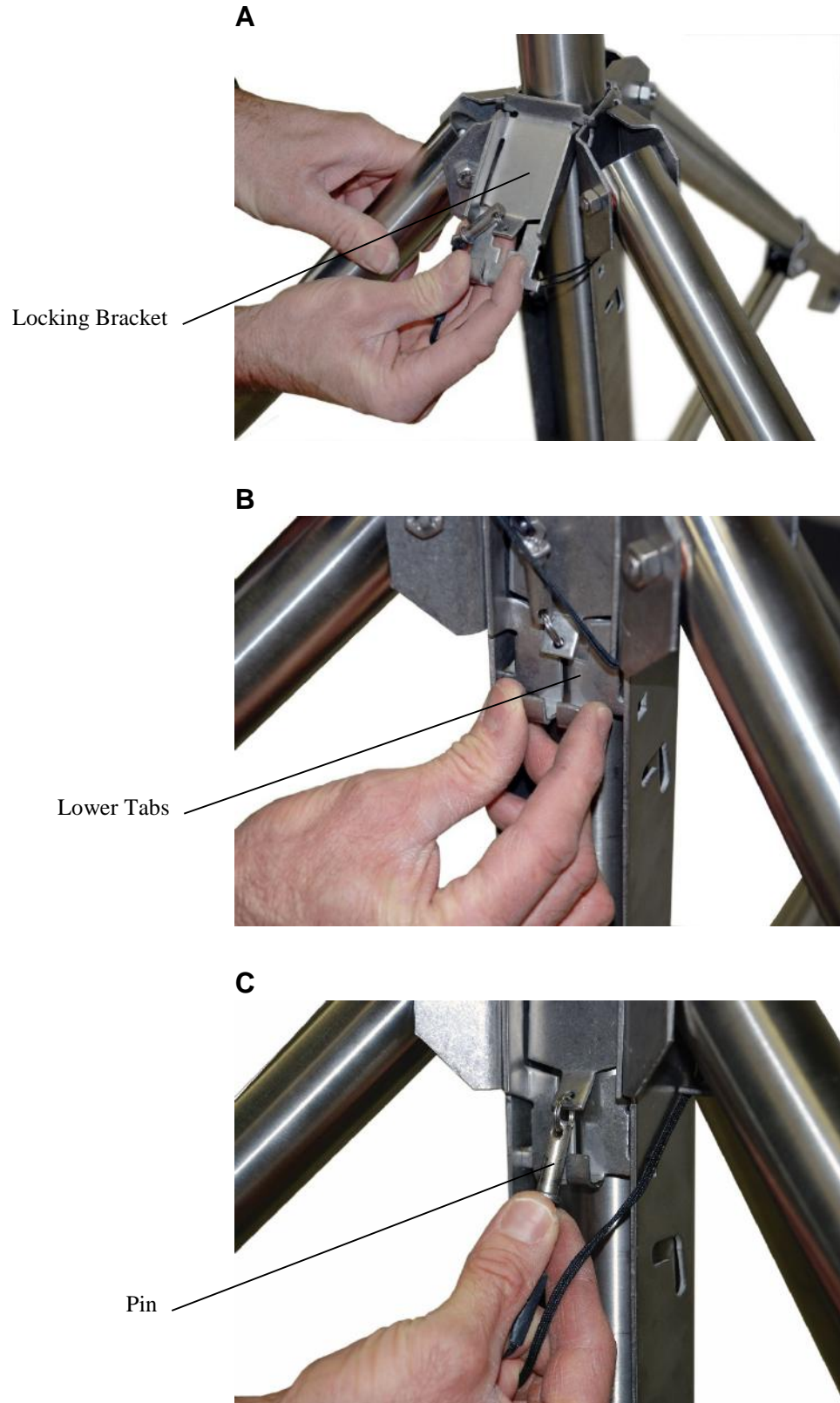

FIGURE 6-4. Mast lock bracket

6.1.3 Installing the Guy Kit

The CM115 and CM120 tripods include a guy kit; the guy kit is an option for the CM110. With the mast tilted down in the horizontal position, install the guy collar over the mast insert, and attach the guy wires as shown in FIGURE 6-5. Return the mast to the upright position and install the locking bracket.

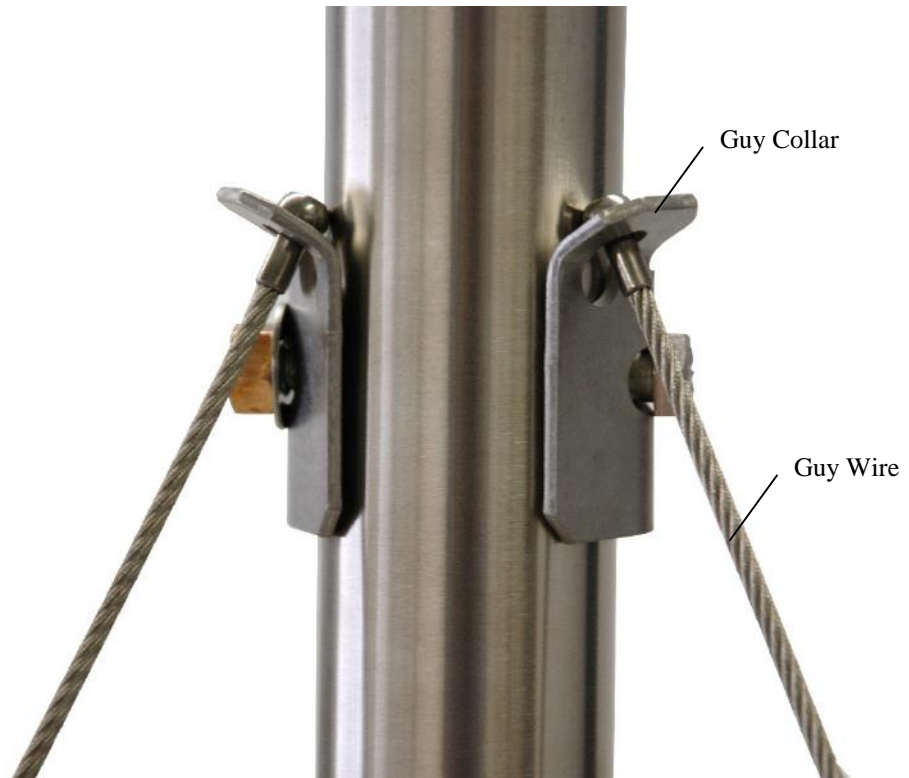

FIGURE 6-5. Guy collar

On the end of each guy line is a case consisting of a hook, clamp, and lever arm. Rotate the lever arm to the “open” position, and attach the hook to the tripod leg as shown in FIGURE 6-6. Loosen the Phillips screw, and remove the slack in the guy line by feeding the load end of the guy wire through the wedge while pulling up on the dead end (FIGURE 6-7).

After the slack has been removed from the guy lines, tighten the Phillips screws and rotate the lever arms to “closed” position to tension the guy lines (FIGURE 6-6).

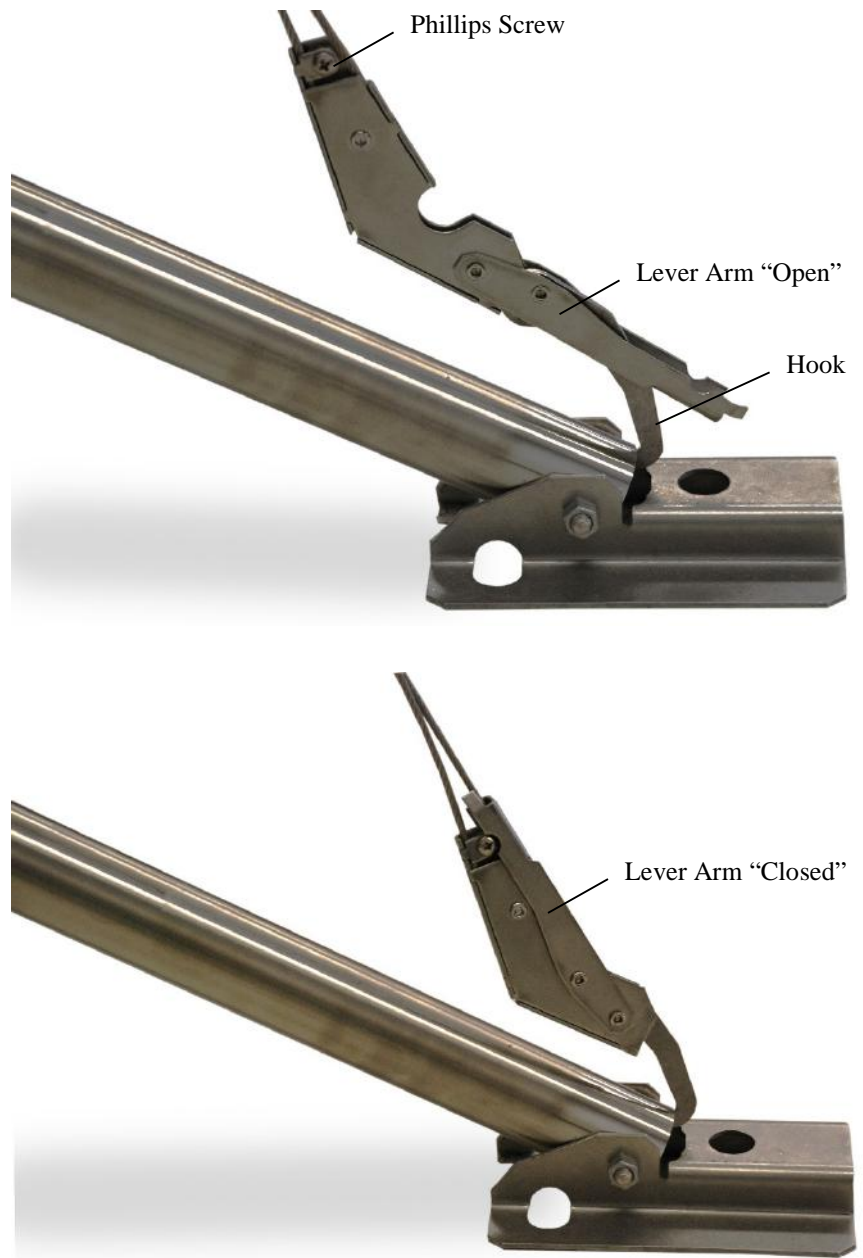

FIGURE 6-6. Guy cinch and lever arm

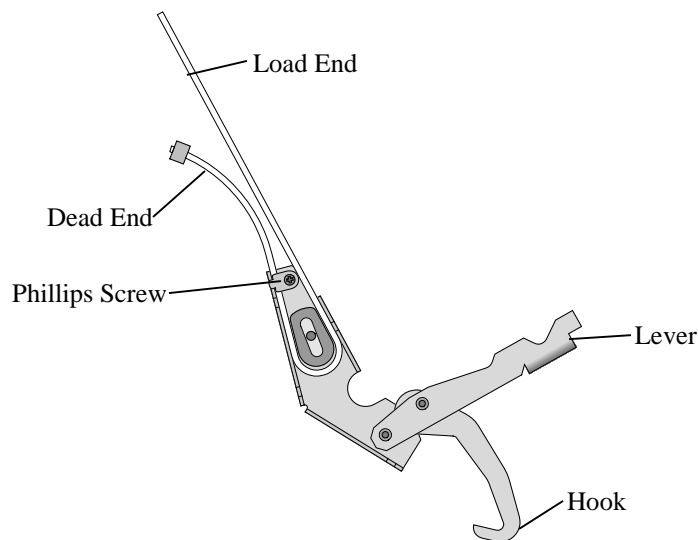

FIGURE 6-7. Mechanical drawing of guy hook and case

6.1.3.1 Guy Duckbill Anchor Kits

Duckbill anchors are recommended for areas subjected to higher winds. They allow the guy wires to be anchored at points beyond the feet, thereby increasing the rating of the tripod for higher winds.

Two duckbill anchor kits are offered for these lightweight tripods. The 19282 Guy Duckbill Standard Anchor Kit is for standard soils, and the 25699 Guy Duckbill Heavy Duty Kit is for aggressive soils. Aggressive soils have:

- Resistivity less than 3000 ohm-cm
- pH less than 5
- Chloride greater than 1000 ppm
- Sulfate greater than 500 ppm
- Poor aeration

The 19282 and 25699 have their own drive bar. The 19282 also has three duckbill anchors with a cable attached to each of them. At the end of the cable is a loop for connecting the guy wires. The 25699 has a threaded rod attached to each of the three duckbill anchors instead of the cable. At the end of the threaded rod is a metal ring for connecting the guy wires.

The duckbill anchors are driven to the ground at a 60-degree guy angle as shown in FIGURE 6-8. Locate the anchors on an 8.7-ft radius for the CM115, or an 11.5-ft radius for the CM120 as shown in FIGURE 6-9. Specifications for sustained wind speed and gust tolerance are given based on guy angle, and the ability of the anchors to hold at least 400 lbf.

NOTE

Duckbill anchors are not suitable for rocky or sandy soils; UTEYE anchors should be considered for these types of soils.

It is important that the anchors be driven at the same angle as the guy wires. Insert the drive bar into the anchor body and drive the anchor into the ground using a sledgehammer until only the top half of the loop or metal ring remains above the ground. Place a bar or highlift jack through the loop or metal ring and jack the anchor up about four inches to rotate the anchor into the load-lock position.

WARNING

Failure to install and lock the anchor at the correct angle will result in the anchor cable cutting through the soil until the angles equalize, causing slack.

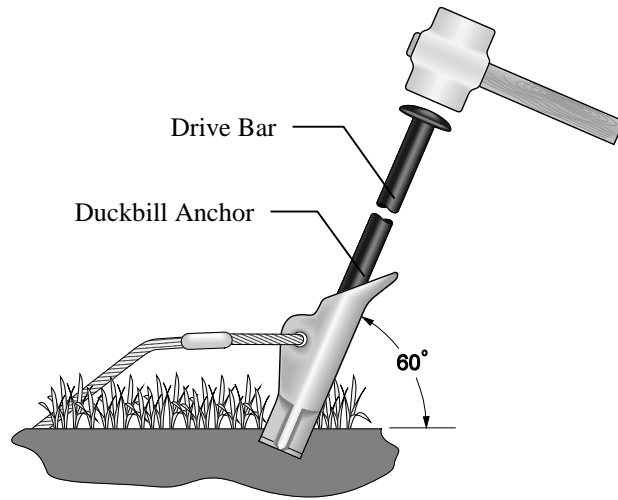
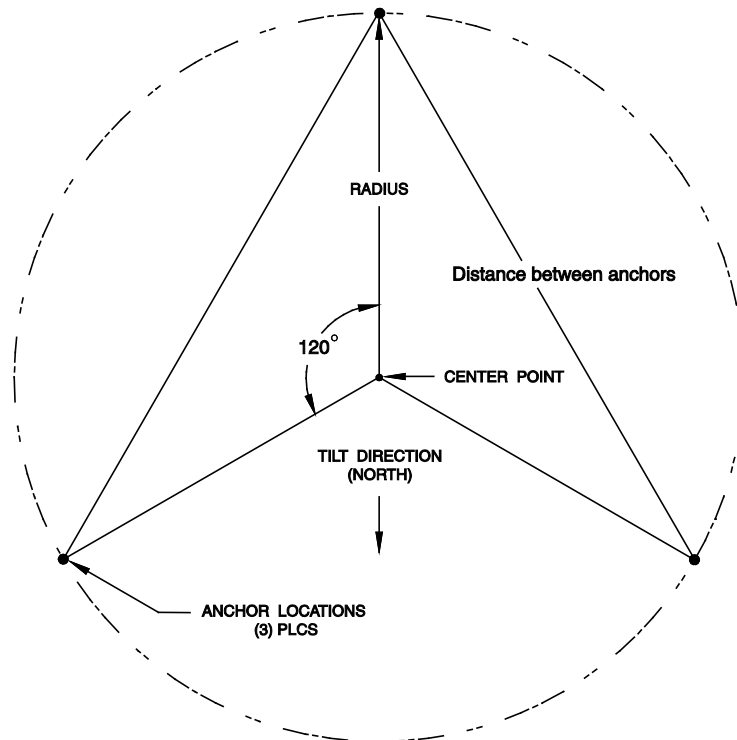

FIGURE 6-8. Duckbill guy anchor



	Radius	Distance Between Anchors
CM115	8.7 ft	15.1 ft
CM120	11.5 ft	19.9 ft

FIGURE 6-9. Top view and guy anchor layout

6.1.3.2 Lowering Mast after Attaching Guy Wires

Once the guy lines have been adjusted, the lever arms can be “opened” and the guy hooks removed to allow the mast to be lowered to the horizontal position.

6.1.4 Staking the Tripod Feet

Six stakes are provided for securing the tripod feet to the ground. Drive two stakes through holes in each foot at an angle as shown in [FIGURE 6-10](#).

Stakes may not be adequate depending on soil structure, maximum wind speeds experienced at the site, mast height, or wind load from the instrumentation. For questionable situations, additional stakes (pn 17049) or even concrete footings for the tripod feet and guy anchors should be considered.



FIGURE 6-10. Staking the tripod feet

6.1.5 Tripod Grounding

Place the clamp over the ground rod and drive the rod (close to the center of the tripod) using a sledgehammer or fence post driver. Strip 1/2 in. of insulation from both ends of the black 4 AWG ground wire. Insert one end of the ground wire between the clamp and ground rod and tighten the bolt on the clamp. Attach the other end of the ground wire to the lug on the tripod base as shown in FIGURE 6-12.



FIGURE 6-11. Ground rod and clamp

Strip 1/2 in. of insulation from the ends of the green 12 AWG wire. Attach one end of the wire to the tripod ground lug, and the other end to the enclosure ground lug as shown in FIGURE 6-12.

Mount the lightning rod and clamp to the tripod mast as shown in FIGURE 6-12.

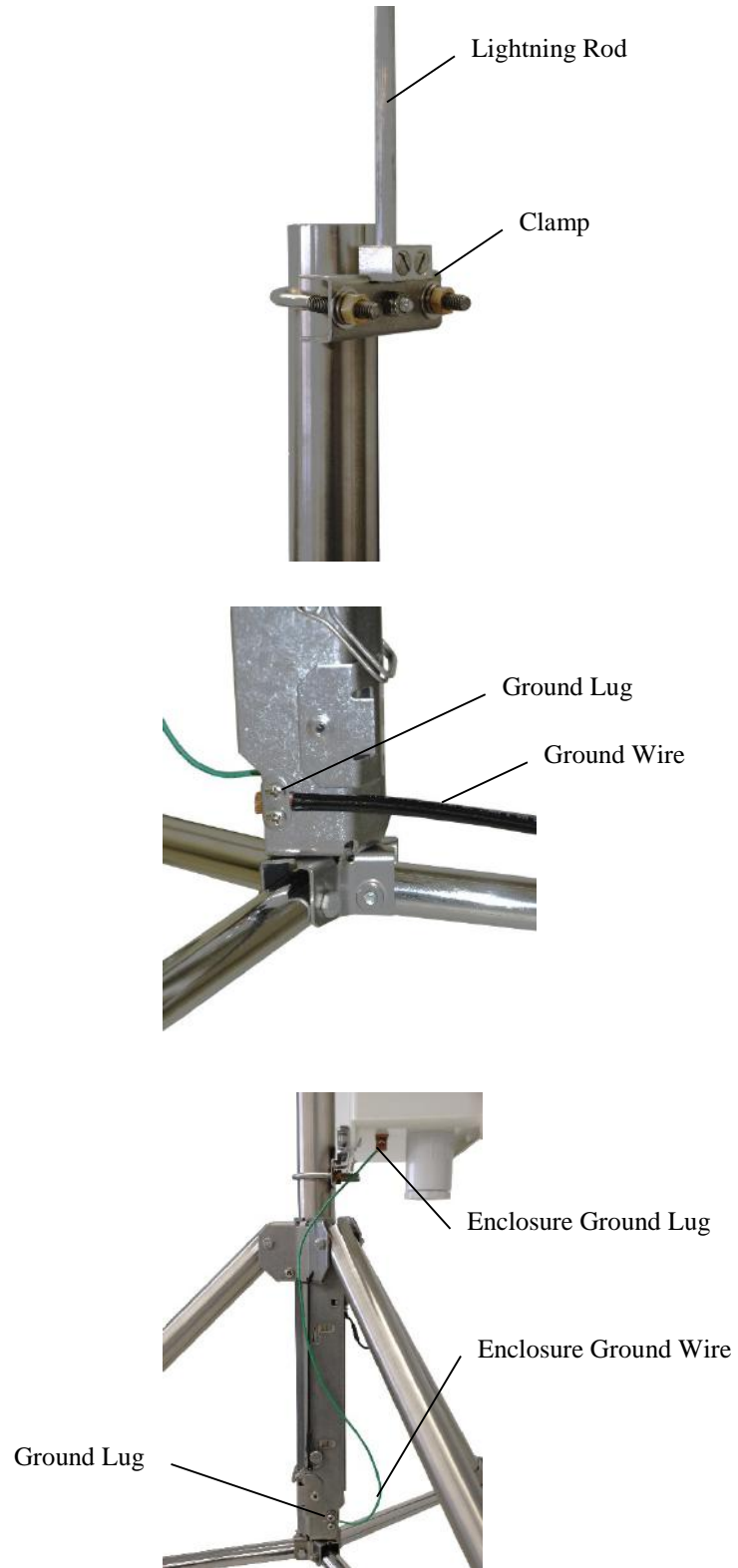

FIGURE 6-12. Lightning rod and tripod ground lug

6.1.6 Crossarm Attachment

Attach the CM202 (2 ft, 0.6 m), CM204 (4 ft, 1.2 m), or CM206 (6 ft, 1.8 m) crossarm to the tripod mast as shown in FIGURE 6-13. For wind sensors, the crossarm should be approximately 103 inches above the ground for a 3 m mounting height, or 64 inches for a 2 m mounting height. Typically the crossarm is oriented east/west for wind sensors, north/south for pyranometers.

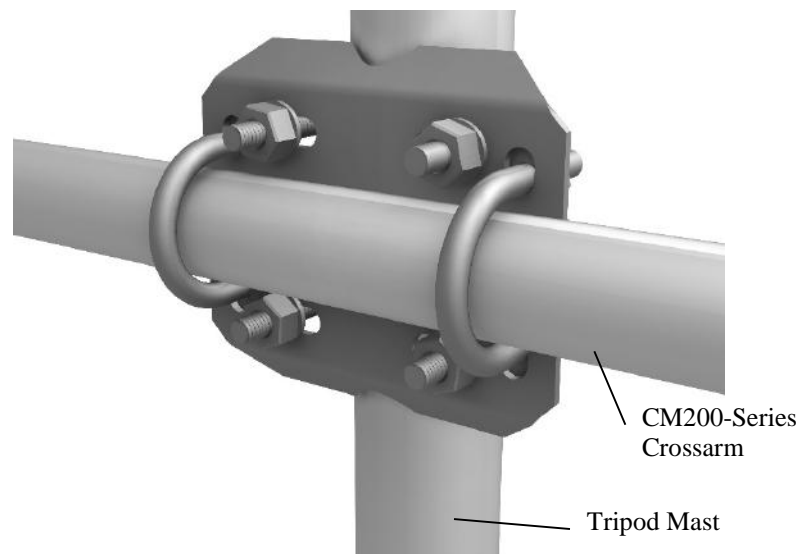

FIGURE 6-13. CM200-series crossarm

6.1.7 Enclosure Attachment

The ENC10/12, ENC12/14, ENC14/16, and ENC16/18 enclosures can be ordered with mounting brackets for the CM100-series tripods. All enclosure models can be mounted to the tripod mast (above the legs) with the –MM Mast Mount bracket option. All enclosure models except the ENC16/18 can be mounted to the tripod base and leg with the –LM Leg Mount bracket option. Two enclosures with the –LM brackets can be mounted in a “back to back” configuration.

6.1.7.1 Enclosure Mounting to Tripod Mast

An enclosure ordered with the –MM bracket has a three-piece top and bottom brackets with a U-bolt for each bracket.

Attach an enclosure with the –MM mounting bracket to the tripod mast as follows:

- Remove the U-bolts, washers, and nuts from the brackets.
- Position the enclosure against the tripod’s mast (north side recommended).
- Install the U-bolts, flat washers, lock washers, and nuts. Tighten the nuts until the lock washers are compressed.

- Route the 14 AWG wire from the ground lug on the bottom side of the enclosure to the ground lug on the base of the tripod (FIGURE 6-14). Strip 1/2 in. of insulation from each end of the wire. Insert wire ends into the ground lugs and tighten.

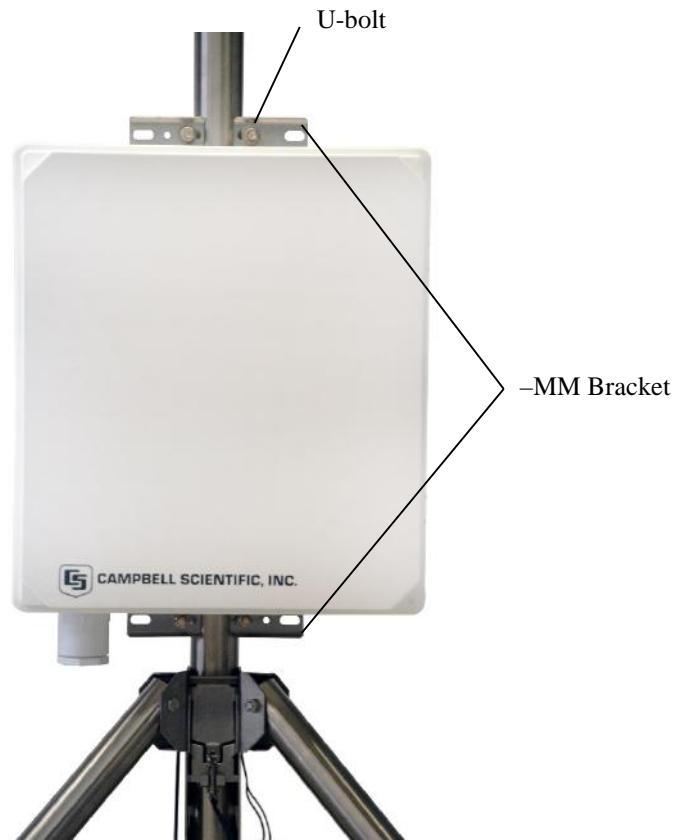

FIGURE 6-14. Enclosure with the -MM bracket

6.1.7.2 Enclosure Mounting to Tripod Leg

An enclosure ordered with the -LM bracket has a bracket on each side of the enclosure, and a U-bolt bracket for securing the enclosure to a tripod leg.

Attach an enclosure with the -LM mounting bracket to the tripod base as follows:

- Slide the keyhole notches in the upper and lower corners of the -LM bracket over the two extended Phillips head screws located on the tripod base as shown in FIGURE 6-15B.
- Remove the washers, nuts, and U-bolt from the U-bolt bracket. Install the bracket as shown in FIGURE 6-15C. Tighten the nuts on the U-bolt until the lock washers are compressed.
- Route the 14 AWG wire from the ground lug on the bottom side of the enclosure to the ground lug on the base of the tripod (FIGURE 6-15). Strip 1/2 in. of insulation from each end of the wire. Insert wire ends into the ground lugs and tighten.

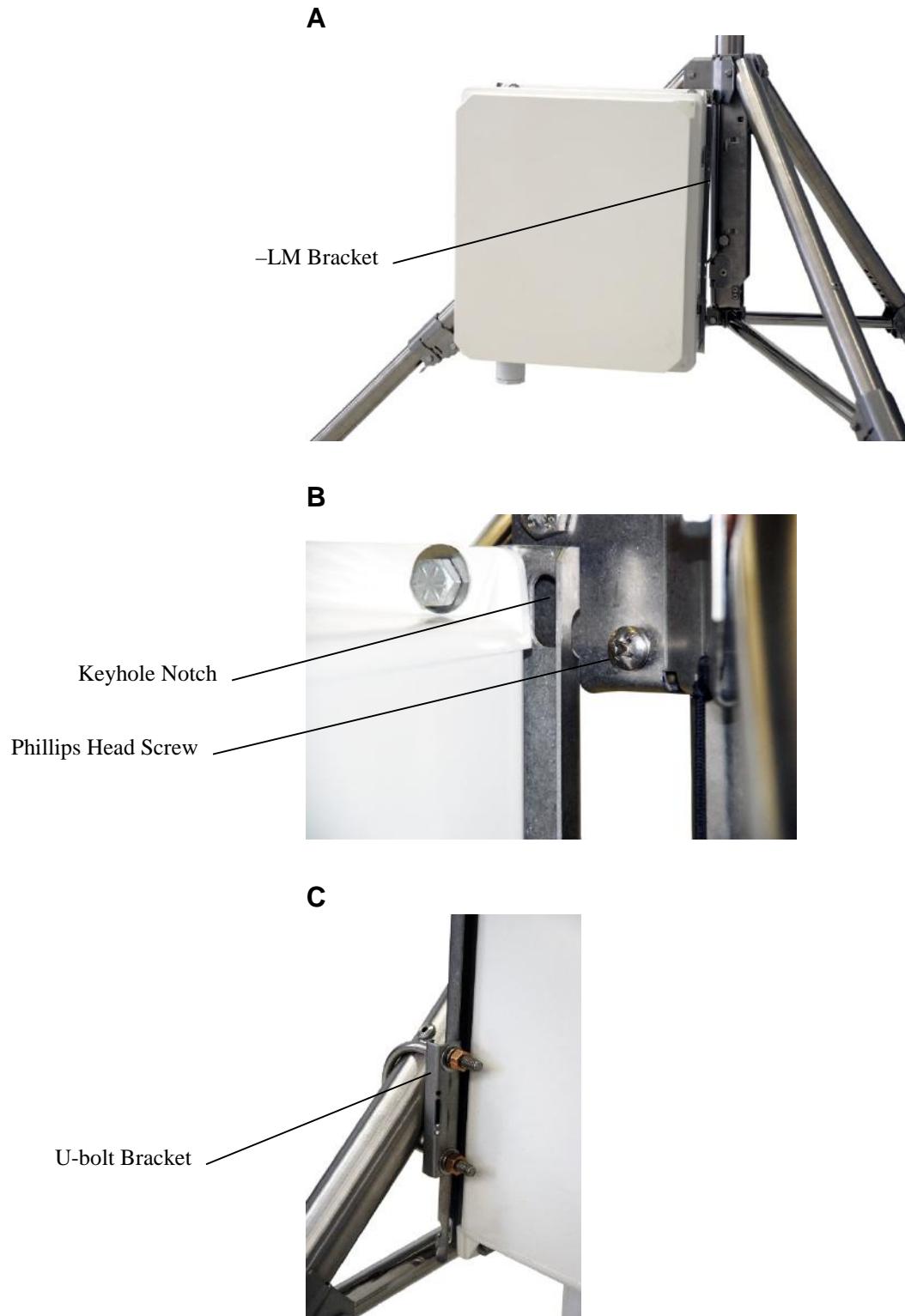

FIGURE 6-15. Enclosure with the -LM bracket

6.2 Mounting Brackets

Mounting brackets covered in this section have U-bolts that attach to vertical and/or horizontal pipes with the following ranges of outside diameters:

	Inches	Millimeters	Nominal Pipe Size (inches)
1.5-in U-bolt	1.0 to 1.5	25.4 to 38.1	0.75 to 1
2-in U-bolt	1.3 to 2.1	33.0 to 53.3	1 to 1.5
2-in U-bolt with plastic V-block	1.0 to 2.1	25.4 to 53.3	0.75 to 1.5

Some of the brackets (for example, the CM210) include 1.5-in and 2-in U-bolts to extend the range of pipe diameters the bracket can accommodate. Brackets with holes for a 1.5-in U-bolt will accept a user-supplied 1.75-in U-bolt.

6.2.1 CM210 Crossarm Mounting Kit

CM200-series crossarms include a CM210 bracket as shown in FIGURE 6-16. The CM210 can be ordered separately to attach a user-supplied pipe (1.0 to 1.5 in OD) to a mast or tower leg (1.0 to 2.1 in OD), or to attach a crossarm to two tower legs.

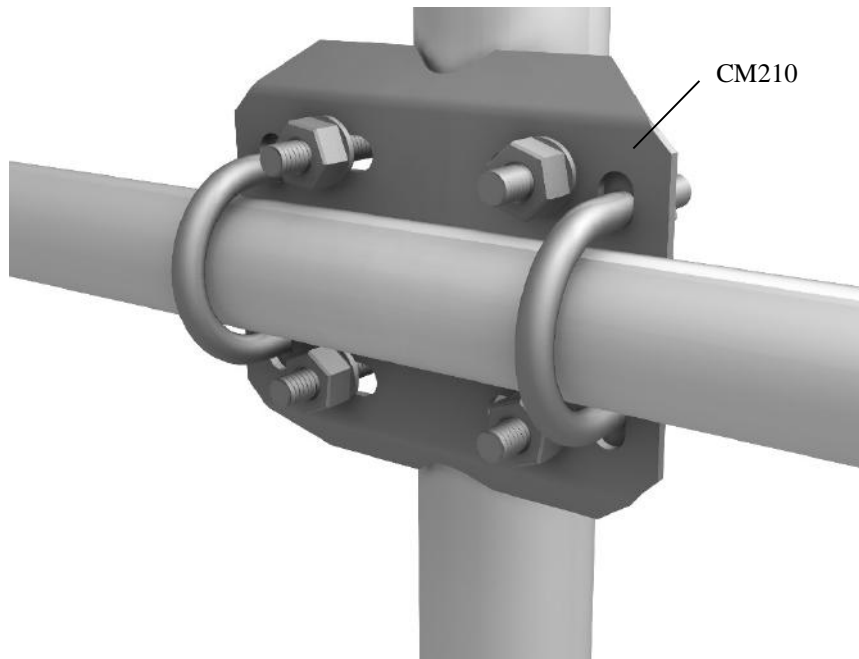

FIGURE 6-16. CM210 Crossarm Mounting Kit (shown with user-supplied pipe)

6.2.2 CM216 Mast Mounting Kit

The CM216 attaches to the top of the mast, and provides a 3/4-in or 1-in mounting pipe (1.05 or 1.32 in OD) that extends 4 in. above the mast, as shown in FIGURE 6-17.



FIGURE 6-17. CM216 Mast Mounting Kit

6.2.3 CM220 Right Angle Mounting Kit

The CM220 attaches a vertical pipe (1.0 to 1.5 in OD) to the CM200-series crossarms or horizontal pipe (1.0 to 1.5 in OD) as shown in FIGURE 6-18.



FIGURE 6-18. CM220 Right Angle Mounting Kit

6.2.4 CMB200 Crossarm Brace Kit

6.2.4.1 Overview

The CMB200 Crossarm Brace Kit (FIGURE 6-19) is designed to provide additional stability to crossarms mounted on Campbell Scientific tripods and towers. It provides additional support for crossarms with heavier sensor loads, and added stability in high winds.

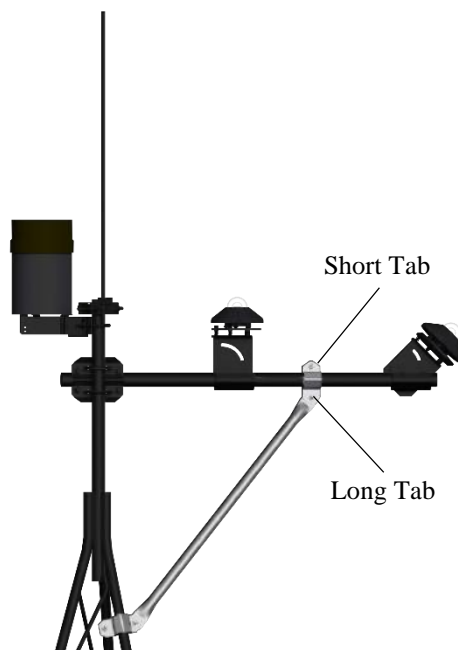

FIGURE 6-19. CMB200 Crossarm Brace Kit

6.2.4.2 Components

The CMB200 ships with the following components (FIGURE 6-20):

- (1) Brace Arm
- (2) Small bracket
- (2) Medium bracket
- (2) Large bracket
- (4) 1/4-20 x 1-inch bolt
- (8) 1/4 flat washer
- (4) 1/4 lock washer
- (4) 1/4-20 nut

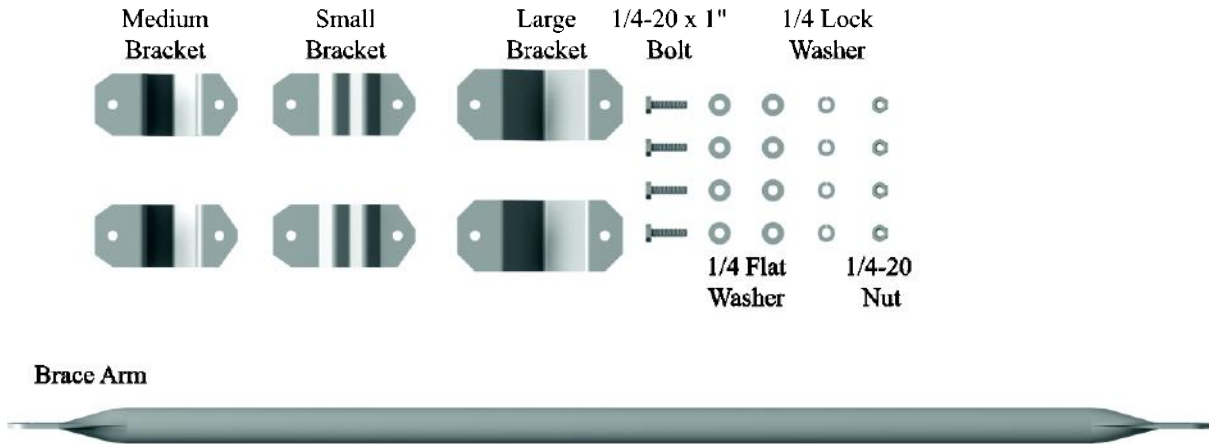

FIGURE 6-20. CMB200 components

6.2.4.3 Assembly

1. Consult FIGURE 6-21 and TABLE 6-1 to determine which brackets are needed at either end of the brace to attach it to the crossarm and tripod mast or tower. The figure also indicates what orientation is needed when the small bracket is used.

NOTE

Each bracket has a long tab and short tab where the bolts are attached. The brace arm must be attached to the end with the long tab.

2. Attach one end of the brace arm to the tripod mast or tower below the crossarm. Leave the bolts finger-tight.
3. Lift the free end of the brace arm to the crossarm and attach it to the crossarm. Again, only finger-tighten the bolts.
4. Adjust the position of the brace arm as needed.
5. Fully tighten the two bolts directly connected to the brace arm, and then tighten the remaining two bolts to clamp the brace arm to the crossarm and tower or tripod mast.

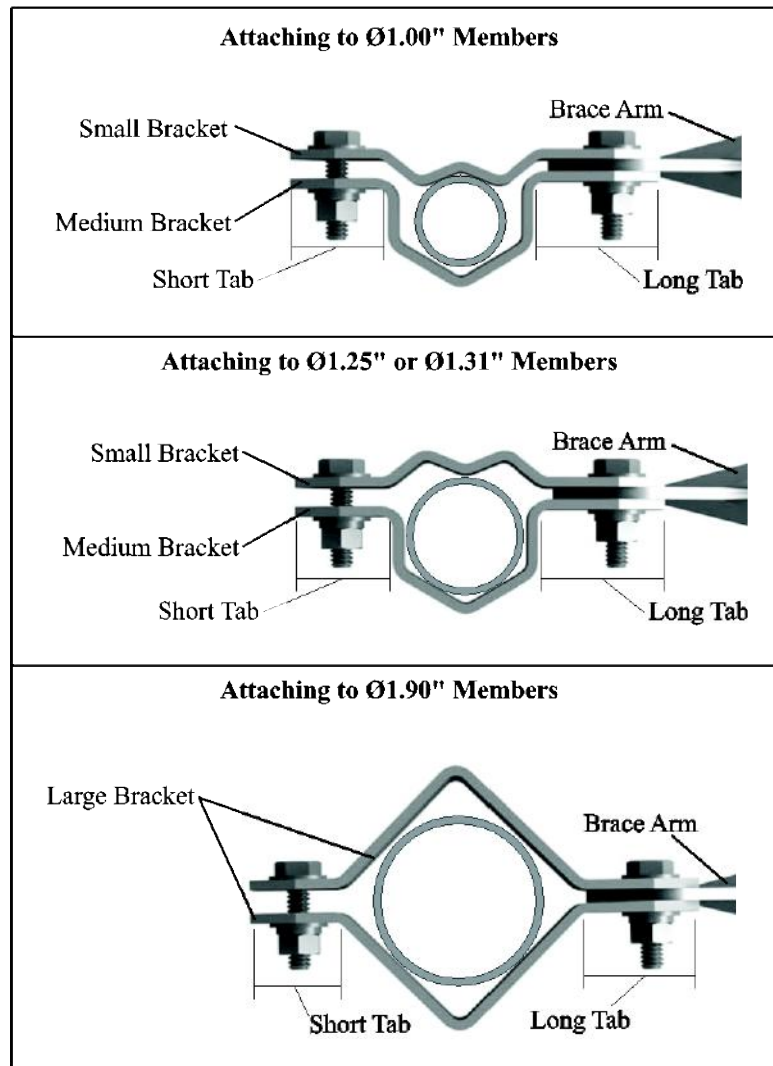

FIGURE 6-21. Bracket selection

TABLE 6-1. Bracket Requirements			
Mast/Crossarm/ Tower Diameter	Example Mast/Crossarm/Tower	Brackets Needed	Small Bracket Orientation
Ø1.00 in	UT10/20/30 Tower Leg (excludes bottom section of UT20/30)	(1) Small Bracket (1) Medium Bracket	Angled toward mast/tripod
Ø1.25 in or Ø1.31 in	CM202/3/4/6 Crossarm, UT20/30 Tower Mast, UT20/30 Tower Leg (bottom section only)	(1) Small Bracket (1) Medium Bracket	Angled away from mast/tripod
Ø1.90 in	CM110/106B Tripod Mast, UT10 Tower Mast	(2) Large Bracket	N/A

6.2.5 CM225 and 18098 Pyranometer Mounting Stand

The CM225 is used to attach a pyranometer or quantum sensor to a horizontal pipe (1.0 to 2.1 in OD) or vertical pole (1.0 to 2.1 in OD).

The LI200X pyranometer and LI190SB quantum sensor mount to the CM225 via the LI200S leveling base (see FIGURE 6-22). The CS300 pyranometer mounts to the CM225 via the 18356 leveling base. The CMP3 and LP02 pyranometers include their own bubble level and leveling screws allowing them to mount directly to the CM225.

The 18098 mounting stand provides a larger surface for mounting a user-supplied Eppley pyranometer.

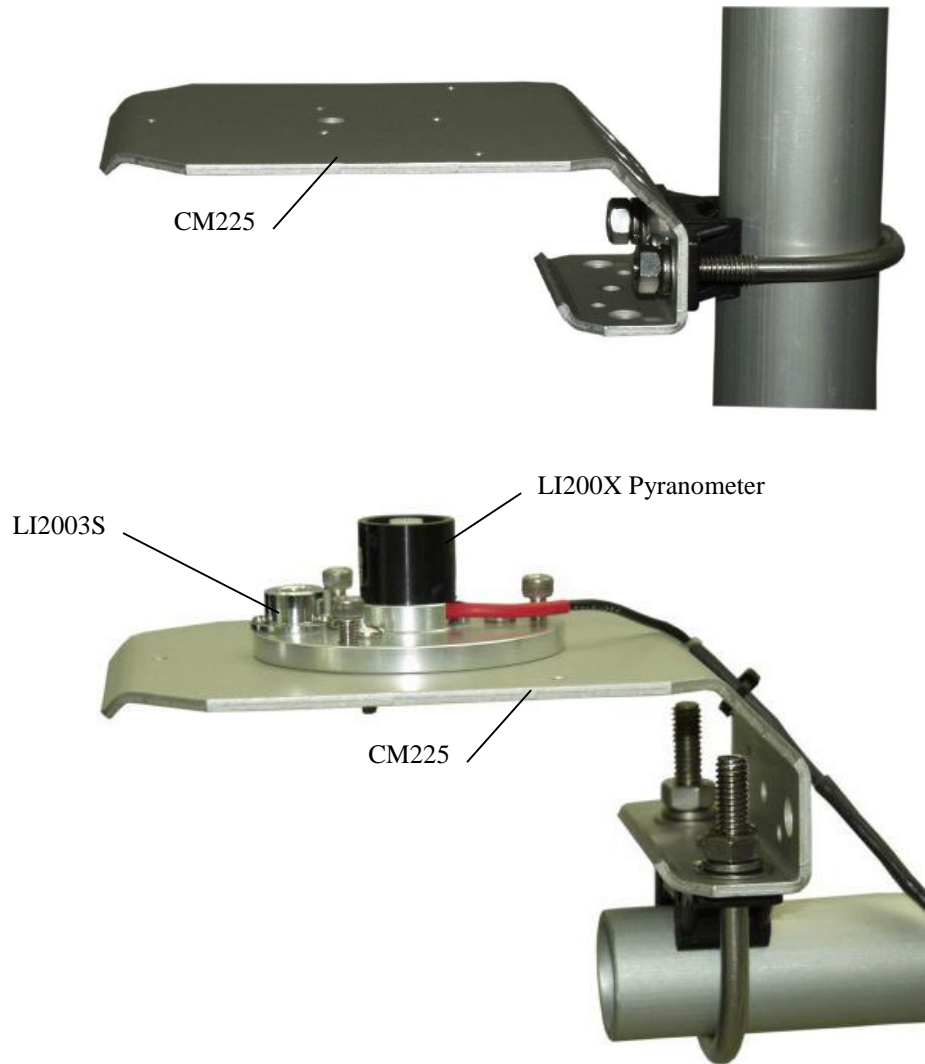

FIGURE 6-22. CM225 Pyranometer Mounting Stand

6.2.6 CM230 and CM230XL Adjustable Angle Mounting Kits

The CM230 mounts an antenna (1.0 to 1.5 in OD) to a mast or vertical pipe (1.3 to 2.1 in OD) as shown in FIGURE 6-23. The bracket allows the antenna to be adjusted for different angles.

The CM230XL is similar to the CM230, but has a longer mounting arm (see FIGURE 6-23). Its longer length places the antenna or sensor away from the mast or pole.

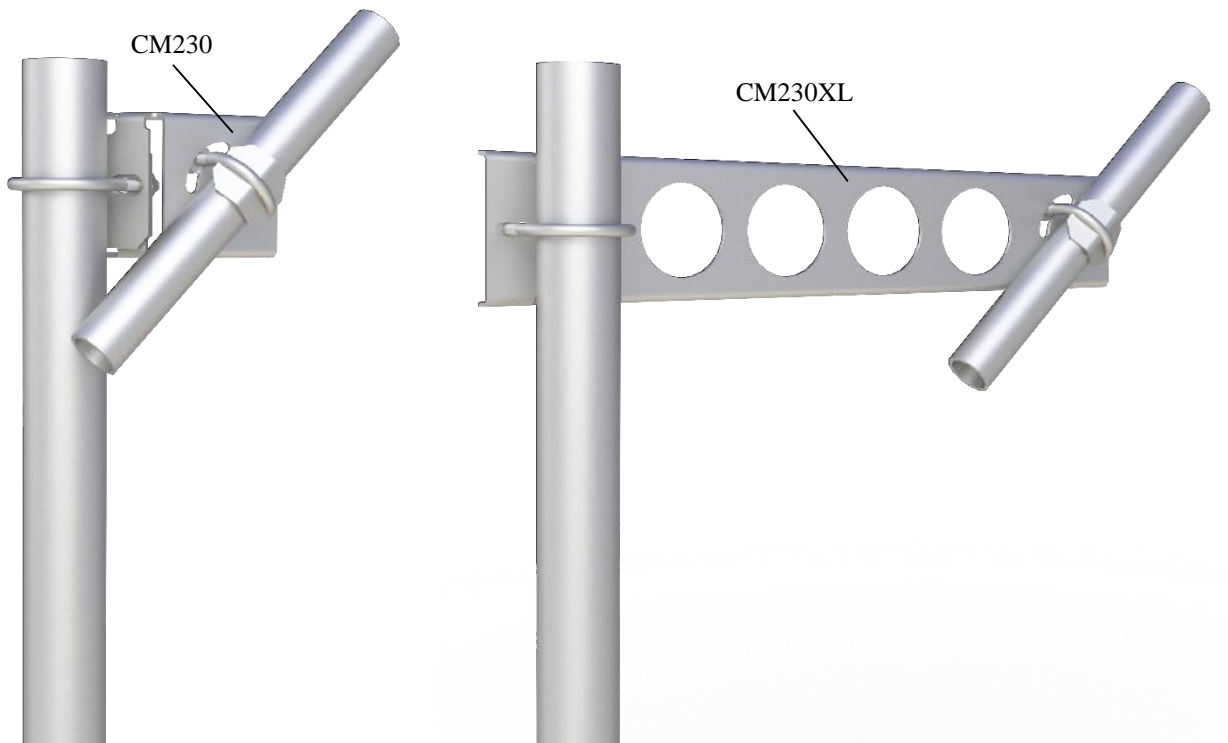

FIGURE 6-23. CM230 and CM230XL Adjustable Angle Mounting Kits

6.2.7 CM235 Magnetic Mounting Stand

The CM235 provides a 3.5 in (8.8 cm) square platform for mounting magnetic base antennas. The CM235 attaches to horizontal or vertical pipes (1.0 to 2.1 in OD) as shown in FIGURE 6-24.



FIGURE 6-24. CM235 Magnetic Mounting Stand

6.2.8 RM Young Multi-Plate Radiation Shields

RM Young Multi-Plate Radiation Shields are used to house and attach temperature and relative humidity sensors to the tripod mast (1.0 to 2.1 in OD) or crossarm as shown in FIGURE 6-25. Radiation shields ship with the U-bolt configured for attachment to a vertical pipe. To attach the radiation shield to a horizontal pipe, the U-bolt and plastic V-block must be moved to the other set of holes.



FIGURE 6-25. RM Young Multi-Plate Radiation Shield

Appendix A. Tripod Tote Bag

The Tripod Tote Bag is an option for the CM110-series tripods. The bag is constructed of nylon, with a main compartment for the tripod base, and pockets for stowing the other components as shown below:

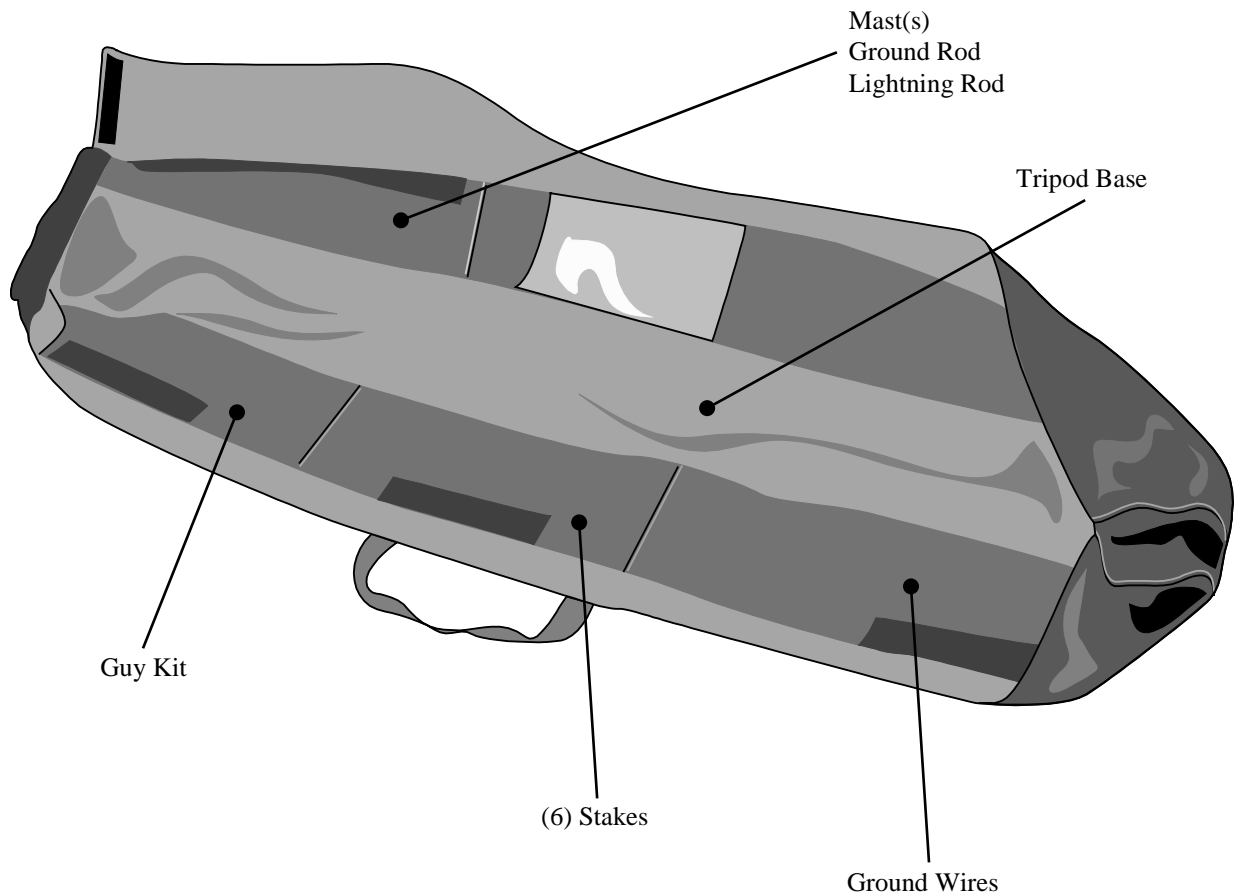

Campbell Scientific Companies

Campbell Scientific, Inc.

815 West 1800 North
Logan, Utah 84321
UNITED STATES

www.campbellsci.com • info@campbellsci.com

Campbell Scientific Canada Corp.

14532 – 131 Avenue NW
Edmonton AB T5L 4X4
CANADA

www.campbellsci.ca • dataloggers@campbellsci.ca

Campbell Scientific Africa Pty. Ltd.

PO Box 2450
Somerset West 7129
SOUTH AFRICA

www.campbellsci.co.za • cleroux@csafrica.co.za

Campbell Scientific Centro Caribe S.A.

300 N Cementerio, Edificio Breller
Santo Domingo, Heredia 40305
COSTA RICA

www.campbellsci.cc • info@campbellsci.cc

Campbell Scientific Southeast Asia Co., Ltd.

877/22 Nirvana@Work, Rama 9 Road
Suan Luang Subdistrict, Suan Luang District
Bangkok 10250
THAILAND

www.campbellsci.asia • info@campbellsci.asia

Campbell Scientific Ltd.

Campbell Park
80 Hathern Road
Shephed, Loughborough LE12 9GX
UNITED KINGDOM

www.campbellsci.co.uk • sales@campbellsci.co.uk

Campbell Scientific Australia Pty. Ltd.

PO Box 8108
Garbutt Post Shop QLD 4814
AUSTRALIA

www.campbellsci.com.au • info@campbellsci.com.au

Campbell Scientific Ltd.

3 Avenue de la Division Leclerc
92160 ANTONY
FRANCE

www.campbellsci.fr • info@campbellsci.fr

Campbell Scientific (Beijing) Co., Ltd.

8B16, Floor 8 Tower B, Hanwei Plaza
7 Guanghua Road
Chaoyang, Beijing 100004
P.R. CHINA

www.campbellsci.com • info@campbellsci.com.cn

Campbell Scientific Ltd.

Fahrenheitstraße 13
28359 Bremen
GERMANY

www.campbellsci.de • info@campbellsci.de

Campbell Scientific do Brasil Ltda.

Rua Apinagés, nbr. 2018 – Perdizes
CEP: 01258-00 – São Paulo – SP
BRASIL

www.campbellsci.com.br • vendas@campbellsci.com.br

Campbell Scientific Spain, S. L.

Avda. Pompeu Fabra 7-9, local 1
08024 Barcelona
SPAIN

www.campbellsci.es • info@campbellsci.es

Please visit www.campbellsci.com to obtain contact information for your local US or international representative.