

TDR100-Based System

Time Domain Reflectometry



Campbell Scientific's Time Domain Reflectometry (TDR) system is comprised of the TDR100 Time Domain Reflectometer, a Campbell Scientific CR10X, CR800, CR850, CR1000, or CR3000 datalogger, SDMX50 coaxial multiplexers, TDR probes and PCTDR software. User-specific configuration provides flexibility for accurate and reliable soil water content and electrical conductivity measurement. Other applications include rock mass deformation, cable integrity monitoring, solution electrical conductivity, water level detection and laboratory time domain measurements.

Features

- Uses compact, low-cost TDR100 Reflectometer with performance features that match or exceed other available TDR reflectometers (see specifications on last page)
- Makes non-destructive, long-term, in-situ soil measurements
- Provides measurement time of two seconds for water content, electrical conductivity or reflection waveform collection (250 data points)
- Measures up to 512 TDR probes
- Uses PCTDR software to facilitate system setup
- Supports operating temperature range of -40° to 55°C

TDR100 Reflectometer

The TDR100 Time-Domain Reflectometer is the core of the Campbell Scientific Time Domain Reflectometry system. The TDR100 (1) generates a very short rise time electromagnetic pulse that is applied to a coaxial system which includes a TDR probe for soil water measurements and (2) samples and digitizes the resulting reflection waveform for analysis or storage. The elapsed travel time and pulse reflection amplitude contain information used by the onboard processor to quickly and accurately determine soil volumetric water content, soil bulk electrical conductivity, rock mass deformation or user-specific, time-domain measurement.

Up to 16 TDR100s can be controlled using a single Campbell Scientific datalogger. A 250-point waveform is collected and analyzed in approximately two seconds. Each waveform can have up to 2,048 data points for monitoring long cable lengths used in rock mass deformation or slope stability. Averaging up to 128 makes accurate measurements possible in noisy environments.



The TDR100 Reflectometer is the core of Campbell Scientific's Time Domain Reflectometry (TDR) system. TDR systems are widely used to measure soil water content, bulk electrical conductivity, and rock mass deformation. TDR measurements are nondestructive and offer excellent accuracy and precision.

Datalogger

The TDR100-based system is supported by our CR10X, CR800, CR850, CR1000, and CR3000 dataloggers. The datalogger is easily programmed for automatic control of the TDR100 and SDMX50 multiplexers as well as telecommunication functions for obtaining measurement results remotely. To control the TDR100, the CR10X uses Instruction 119 and the CR800, CR850, CR1000, and CR3000 use the TDR100 instruction. The CR10X operating system (OS) should be version 1 rev. 13 or higher. All CR800, CR850, CR1000, and CR3000 operating systems (OS) are compatible with the TDR100.

Power Supply

The power supply requirements depend on the number of sensors measured, how frequently the data's retrieved, data retrieval method used, and location of the site. A typical system that measures 15 TDR sensors and uses phone modems to retrieve data every two hours can use the datalogger's sealed rechargeable battery recharged by a 10 W solar panel.

Systems that measure more sensors, use a high current drain telecommunications method such as satellite transmitters, or retrieve data more frequently may require a user-supplied, deep-cycle rechargeable battery recharged with a 20 W solar panel. For information about analyzing your system's power requirements, see our Power Supply product brochure or application note 5-F. Both can be downloaded from our website at www.campbellsci.com.

Multiplexers

Campbell Scientific offers three multiplexer models, the SDM50 series. Combining multiplexers allows measurement of up to 512 TDR probes. The SDM50 series are 50 ohm, coaxial, 8:1 multiplexers with surge protection; 12 Vdc power is required. The multiplexers use Campbell Scientific's SDM communications protocol and can be controlled via a datalogger or a computer running PCTDR. The models differ only in their packaging.

SDMX50

- Consists of a multiplexer circuit board mounted in an environmental enclosure; inside dimensions of the enclosure are 10" x 12" x 5" (25.4 x 30.4 x 12.7 cm)
- Equipped with a back plate that provides a strain relief point for coaxial cables
- Includes cable ties and desiccant

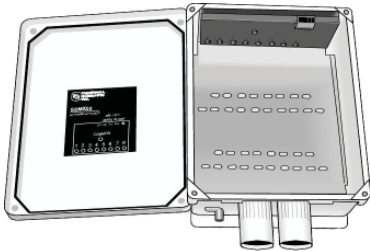

SDMX50LP

- Consists of a multiplexer circuit board attached to one end of a strain relief back plate; dimensions of the back plate are 11.25" x 9.75" x 0.5" (28.6 x 24.8 x 1.3 cm)
- Mounts inside of a user-supplied enclosure
- Includes cable ties

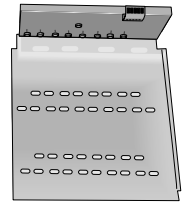

SDMX50SP

- Consists of a multiplexer circuit board enclosed in a metal housing and a separate strain relief bracket; dimensions of the multiplexer housing are 8.8" x 4.8" x 1.0" (22.3 x 12.2 x 2.5 cm), and dimensions of the strain relief bracket are 8.0" x 1.7" x 0.6" (20.3 x 4.3 x 1.5 cm)
- Mounts to a wall or to the back plate of a user-supplied enclosure or a Campbell Scientific enclosure (e.g., ENCTDR100, ENC12/14, ENC16/18)
- Includes cable ties and mounting hardware

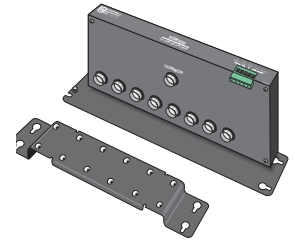

Three Levels of Multiplexers

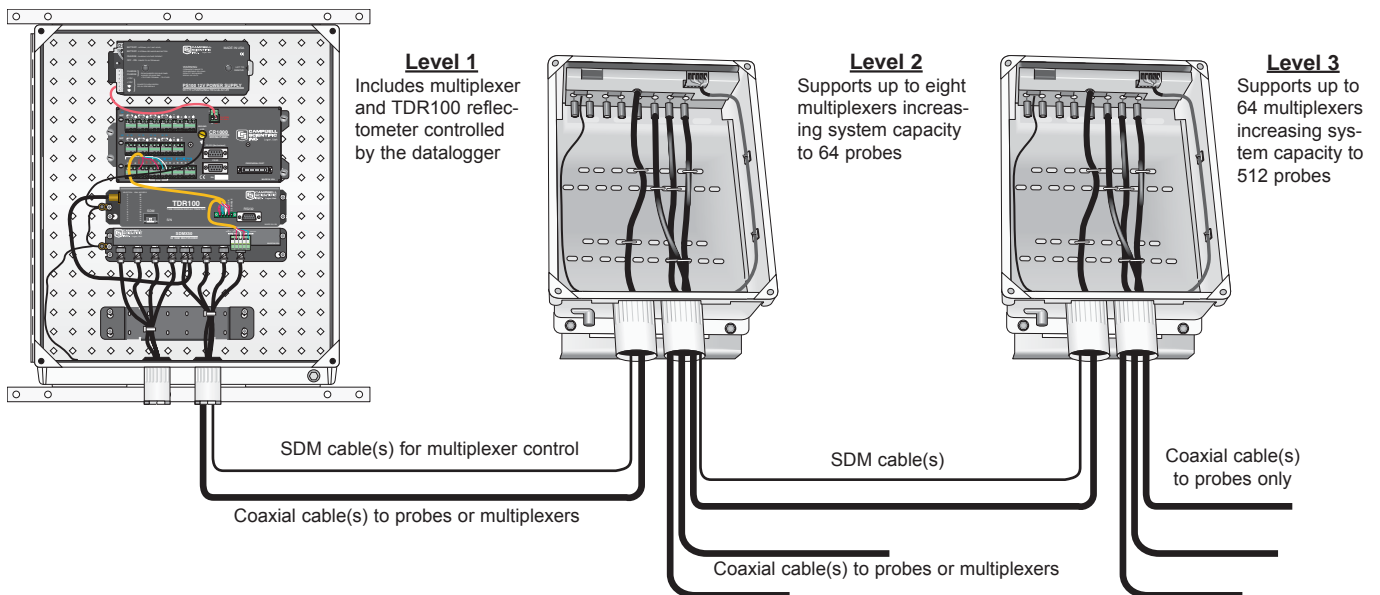

The system can use three multiplexer levels allowing up to 512 probes to be measured. The first level includes the TDR100 and one multiplexer. Up to eight coaxial cables connect to each multiplexer. The coaxial cables can be connected to TDR probes or the next level's multiplexers.

ENCTDR100 Environmental Enclosure

The reflectometer, datalogger, multiplexer and power supply should be housed in an environmental enclosure to protect the equipment from weather, condensing humidity, and dust. Campbell Scientific offers the ENCTDR100 for this purpose.

The ENCTDR100 is a white fiberglass-reinforced polyester enclosure that has internal dimensions of 16" x 18" x 8". It can house the datalogger, datalogger's power supply, TDR100, and SDM50SP (the SDM50 includes its own enclosure and the SDM50LP is intended to be mounted in a separate user-supplied enclosure).

The ENCTDR100 includes interconnecting SDM and coaxial cabling, grounding wires, desiccant, humidity indicator, and hardware for mounting the enclosure on a pole, tripod mast, or tower leg.

Telecommunications

Data retrieved via telecommunications is available using the CR10X, CR800, CR850, CR1000, or CR3000 dataloggers. The dataloggers are compatible with direct connection with the computer, radio telemetry, phone lines (land-line and cellular), multidrop modems, and short-haul modems.

Sensors

Soil TDR Probes

The probes act as a wave guide. Impedance along the rods varies with the dielectric permittivity of the surrounding soil. Because the dielectric permittivity of soil primarily depends on the amount of water present, soil volumetric water content can be inferred from the reflected measurements. Soil bulk electrical conductivity is determined from the attenuation of the applied pulse.

Campbell Scientific offers six soil probes that have different rods and connector cables allowing them to be used in different soil types and with different cable lengths. The probes consist of three pointed rods and a rugged head. Insertion guides are available that aid probe installation.

- **CS605 probe**—recommended for typical soils (soil bulk conductivity ≤ 1.4 dS/m) and cable lengths ≤ 15 m. Probe has an RG58 cable, and rods with a 30-cm length and 0.48-cm diameter.
- **CS610 probe**—recommended for typical soils (soil bulk conductivity ≤ 1.4 dS/m) and cable lengths ≤ 25 m (as measured from the tips of the probe's rods to the TDR100). Probe has an RG8 cable, and rods with a 30-cm length and 0.48-cm diameter.
- **CS630 probe**—recommended for high conductivity soils (soil bulk conductivity ≤ 3.5 dS/m) and cable lengths ≤ 15 m. Probe has an RG58 cable, and rods with a 15-cm length and 0.318-cm diameter.
- **CS635 probe**—recommended for high conductivity soils (soil bulk conductivity ≤ 3.5 dS/m) and cable lengths ≤ 25 m (as measured from the tips of the probe's rods to the TDR100). Probe has an LMR200DB cable, and rods with a 15-cm length and 0.318-cm diameter.

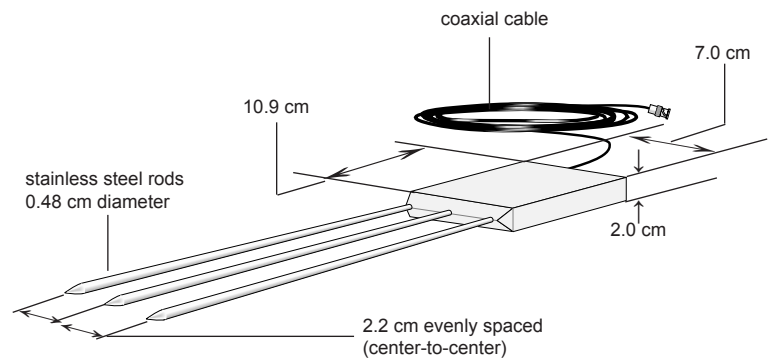

- **CS640 probe**—recommended for very high conductivity soils (soil bulk conductivity ≤ 5 dS/m) or laboratory column applications and cable lengths ≤ 15 m. Probe has an RG58 cable, and rods with a 7.5-cm length and 0.159-cm diameter.
- **CS645 probe**—recommended for very high conductivity soils (soil bulk conductivity ≤ 5 dS/m) or laboratory column applications and cable lengths ≤ 25 m (as measured from the tips of the probe's rods to the TDR100). Probe has an LMR200DB cable, and rods with a 7.5-cm length and 0.159-cm diameter.

Sensor Cables for Rock Mass Deformation

Rock mass deformation applications use a coaxial cable grouted into a borehole to serve as the system's sensor. Crimps at measured intervals along the cable partially reflect the transmitted signal. Crimps appear as small negative polarity events along the trace of the waveform. Events that offset the waveform indicate deformational zones. The polarity of the offset indicates whether a zone is experiencing tensile or shear deformation. Coaxial cable suitable for grouting is obtained by the user.

Software

PCTDR

PCTDR software is used during system setup and troubleshooting to display volumetric water content and electrical conductivity, switch multiplexer channels, collect waveform and derivative data files, and determine probe constant values needed for electrical conductivity measurements. A Windows® 98, NT, 2000 or XP computer operating system is required.

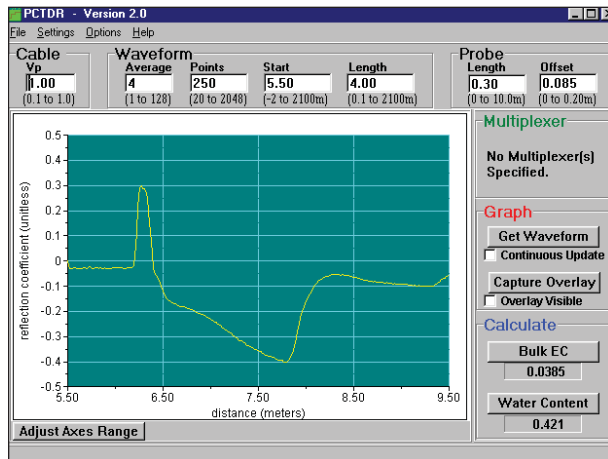

PCTDR displays waveforms for system setup and troubleshooting. A CD containing PCTDR is shipped with each TDR100 Reflectometer. This software is also available, at no charge, from our website.

LoggerNet

LoggerNet Datalogger Support Software provides telecommunications, datalogger programming, data transfer, and data processing functions. The TDR100-based system requires LoggerNet 2.0 or higher. Our CR1000 requires LoggerNet 3.0 or higher; our CR3000 requires LoggerNet 3.2 or higher, and our CR800-series requires LoggerNet 3.3 or higher.

TDRSDK (Optional)

TDRSDK Software Developers Kit allows software developers to customize and simplify the user-interface for the TDR100. The kit consists of a DLL (dynamically linked library) file that gives developers access to the entire TDR100 command set. The TDR100COM.DLL runs in a Windows 98, NT, 2000, XP computer operating system. The custom interfaces can be created using C++, Pascal, or VisualBasic computer languages.

Specifications

We recommend that you confirm system configuration and critical specifications with Campbell Scientific before purchase.

TDR100 Performance

Pulse Generator Output: 250 mV into 50 ohms

Output Impedance: 50 ohms $\pm 1\%$

Time Response of Combined Pulse Generator and Sampling Circuit: ≤ 300 ps

Pulse Generator Aberrations
Within first 10 ns: $\pm 5\%$
After 10 ns: $\pm 0.5\%$

Pulse Length: 14 μ s

Timing Resolution: 12.2 ps

Waveform Sampling: 20 to 2048 waveform values over chosen length

	distance (Vp = 1)	time (1 way travel)
range	-2 to 2100 m	0 to 7 μ s
resolution	1.8 mm	6.1 ps

Waveform Averaging: 1 to 128

Electrostatic Discharge Protection: Internal clamping

Current Drain
During Measurement: 270 mA
Sleep Mode: 20 mA
Standby Mode: 2 mA

Power Supply: Unregulated 12 V (9.6 V to 16 V), 300 mA maximum

Operating Temperature: -40° to $+55^{\circ}$ C

Dimensions: 21 x 11 x 5.5 cm (8.3" x 4.3" x 2.2")

Weight: 700 g (1.5 lb)

Multiplexer Power Requirements

- Multiplexer requires 12 Vdc.
- Quiescent current demand for the multiplexer is less than 1 mA.
- Current demand during switching is approximately 90 mA.
- All multiplexers of the same level switch simultaneously. Switching takes less than 1 s.