

INSTRUCTION MANUAL



MSX10, MSX10R, MSX20R,
MSX64R, and MSX128R
Solar Panels

Revision: 7/05

Warranty and Assistance

The **MSX10, MSX10R, MSX20R, MSX64R, AND MSX128R SOLAR PANELS** are warranted by CAMPBELL SCIENTIFIC, INC. to be free from defects in materials and workmanship under normal use and service for twelve (12) months from date of shipment unless specified otherwise. Batteries have no warranty. CAMPBELL SCIENTIFIC, INC.'s obligation under this warranty is limited to repairing or replacing (at CAMPBELL SCIENTIFIC, INC.'s option) defective products. The customer shall assume all costs of removing, reinstalling, and shipping defective products to CAMPBELL SCIENTIFIC, INC. CAMPBELL SCIENTIFIC, INC. will return such products by surface carrier prepaid. This warranty shall not apply to any CAMPBELL SCIENTIFIC, INC. products which have been subjected to modification, misuse, neglect, accidents of nature, or shipping damage. This warranty is in lieu of all other warranties, expressed or implied, including warranties of merchantability or fitness for a particular purpose. CAMPBELL SCIENTIFIC, INC. is not liable for special, indirect, incidental, or consequential damages.

Products may not be returned without prior authorization. The following contact information is for US and International customers residing in countries served by Campbell Scientific, Inc. directly. Affiliate companies handle repairs for customers within their territories. Please visit www.campbellsci.com to determine which Campbell Scientific company serves your country. To obtain a Returned Materials Authorization (RMA), contact CAMPBELL SCIENTIFIC, INC., phone (435) 753-2342. After an applications engineer determines the nature of the problem, an RMA number will be issued. Please write this number clearly on the outside of the shipping container. CAMPBELL SCIENTIFIC's shipping address is:

CAMPBELL SCIENTIFIC, INC.

RMA#_____

815 West 1800 North

Logan, Utah 84321-1784

CAMPBELL SCIENTIFIC, INC. does not accept collect calls.

MSX Solar Panels Table of Contents

PDF viewers note: These page numbers refer to the printed version of this document. Use the Adobe Acrobat® bookmarks tab for links to specific sections.

1. General	1
2. Specifications	1
3. Installation	2
3.1 Mounting	2
3.2 Orientation	3
4. Maintenance	4
5. Power Considerations	5
5.1 Solar Power and Lead Acid Batteries	5
5.2 Voltage Regulator	6

Appendices

A. Solar Panel Connector	A-1
B. Assembly Instructions for 64 Watt Solar Panel with Mounting Bracket	B-1

Figures

1. Solar Panel Mounting	2
2. Regulated Solar Panel and External Battery	3
3. Angle Settings on Mounting Bracket	4
4. Solar Panel Orientation	5
A-1. Connector Wiring	A-1
B-2. 64 Watt Solar Panel Assembly Instructions	B-1

Tables

1. Solar Panel Tilt Angle	3
2. Configurations for Desired Angles	4
B-1. Mounting Bracket Parts List	B-2

MSX10, MSX10R, MSX20R, MSX64R, and MSX128R Solar Panels

1. General

The solar panel is a photovoltaic power source used for charging lead acid batteries. The MSX10, MSX10R, MSX20R, MSX64R, and MSX128R are 10, 10, 20, 64, and 128-watt solar panels, respectively.

The MSX10 Solar Panels has two leads stripped and tinned to insert into the terminals labeled 'CHG' on the PS100 or PS12LA Charging Regulator. With a CR7, the two wires from the solar panel are inserted into the terminals marked SOLAR PANEL located underneath the 700X Control Module. An external lead acid battery can be connected to the CR7 at the terminals marked EXTERNAL BATTERY next to the SOLAR PANEL terminals.

The MSX10 must have a connector (Part No. 788) to plug into the 21XL Micrologger. See Appendix A for details.

The MSX10R, MSX20R, MSX64R, and MSX128R are regulated solar panels with two stripped and tinned leads for direct connection to an external 12-volt lead acid battery.

2. Specifications

	MSX10/MSX10R	MSX20R	MSX64R	MSX128R
Typical peak power (Pp)	10 W	20 W	64	128
Voltage @ peak power (Vpp) (voltage from solar panel before regulator)	17.5 V	17.1 V	17.5	17.5
Current @ peak power (Ipp)	0.57 A	1.17 A	3.66	7.32
Guaranteed minimum peak power	9 W	18 W	62	124
Approximate effect of temperature on power	-0.37%/°C	-0.38%/°C	-.38/°C	-.38/°C
Length, cm	42.0	50.1	111.3	111.3
Width, cm	26.9	42.2	50.2	100.4
Depth, cm	2.3	5.0	5	5
Weight, kg	1.50	2.95	7.2	14.4

NOTE

The above solar panel characteristics assume a 1 kilowatt per square meter illumination and a solar panel temperature of 25°C. Individual panels may vary up to 10%. The output panel voltage increases as the panel temperature decreases.

*The MSX128R includes two 64-watt solar panels. An MSX64R can be updated to an MSX128R with part number 13968.

3. Installation

3.1 Mounting

The panel should be mounted facing south if located in the Northern Hemisphere, or facing north in the Southern Hemisphere. The solar panel mounts to the mast or leg of the CM10/CM6 Tripod, or any 1 5/8" schedule 40 pipe, see Figure 1. The panel should be mounted to the pipe using the U-bolts and 5/16 NC (course) nuts provided with the solar panel. The nuts fastening the bracket to the pipe should be as tight as possible without bending the bracket.

If the MSX10 solar panel is being used, route the solar panel cable to the datalogger power supply and charging circuitry. If the MSX10R, MSX20R, MSX64R, or MSX128R is being used, attach the leads of the solar panel directly to the external battery with a user supplied connector. Figure 2 shows an example of a regulated solar panel connected to an external battery to run a radiotelemetry system.

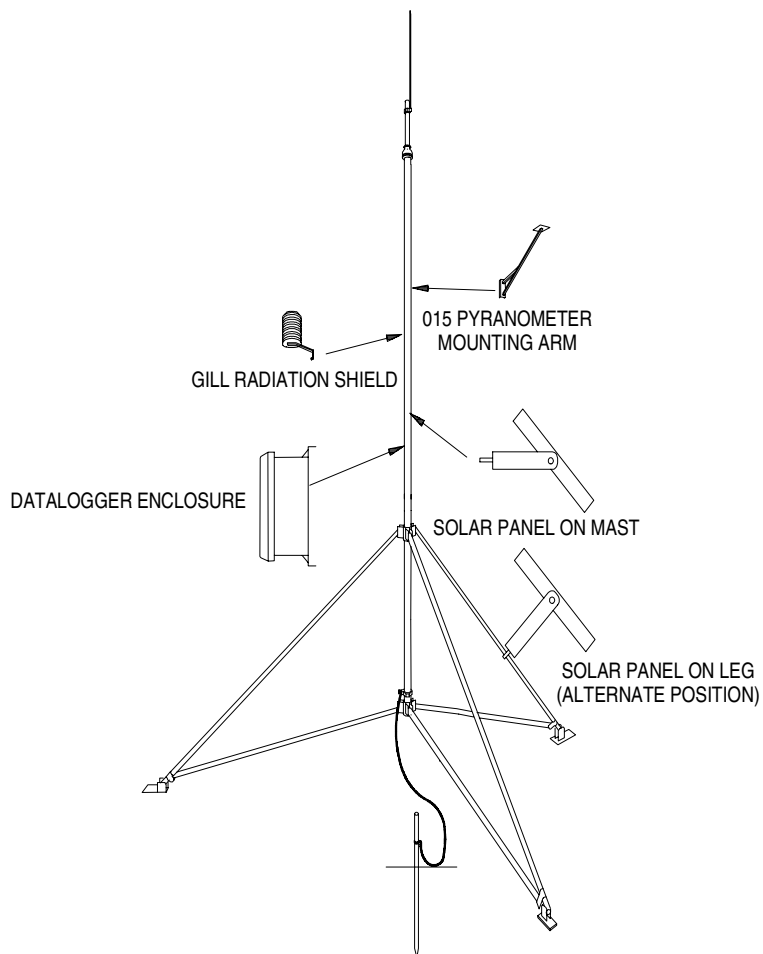

FIGURE 1. Solar Panel Mounting

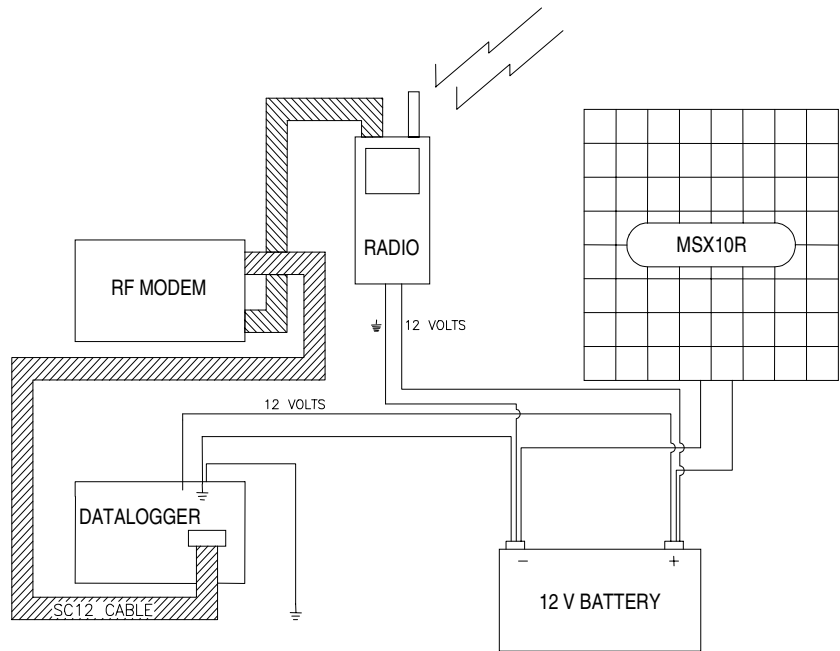

FIGURE 2. Regulated Solar Panel and External Battery

3.2 Orientation

The solar panel should be oriented to receive maximum insolation (incident solar radiation) over the course of a year. Suggested tilt angles of the solar panel are given in Table 1.

After determining the tilt angle, loosen the 5/16" nuts on each side of the solar panel, adjust the panel, and tighten the two nuts to secure the position. See Figure 4.

TABLE 1. Solar Panel Tilt Angle*

<u>Site Latitude (N or S)</u>	<u>Tilt Angle</u>
0 – 10°	10°
11 – 20°	Latitude +5°
21 – 45	Latitude +10°
46 – 65	Latitude +15°
> 65	80°

* From "Design Aids for Small PV Power Systems", Solorex Corp.

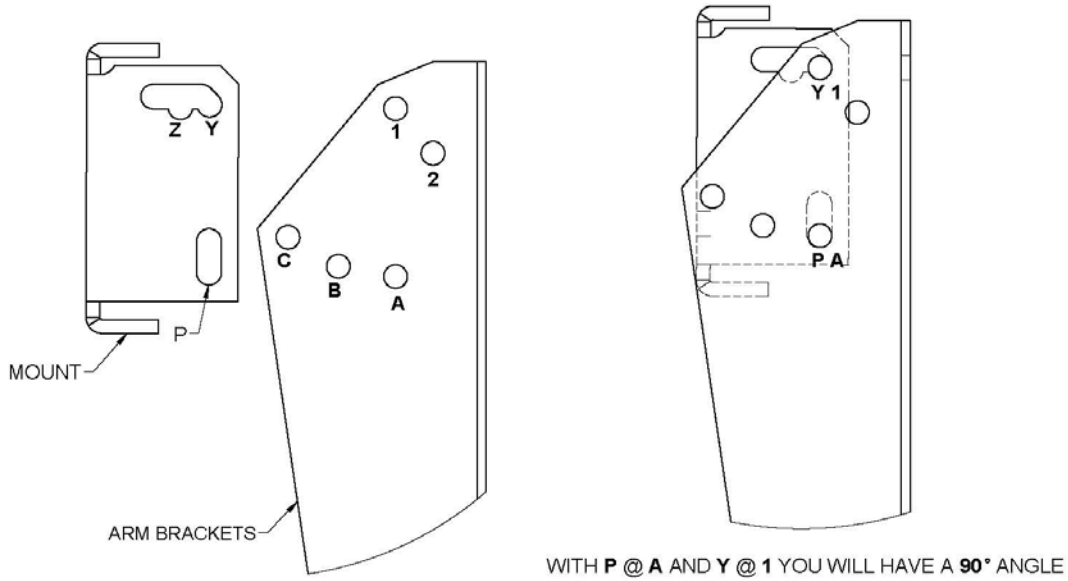

FIGURE 3. Angle Settings on Mounting Bracket

TABLE 2. Configurations for Desired Angles	
Hole Locations	Angle
Holes P and A Aligned with Holes 1 and Y	90
Holes P and A Aligned with Holes 1 and Z	80
Holes P and B Aligned with Holes 1 and Y	70
Holes P and B Aligned with Holes 1 and Z	60
Holes P and C Aligned with Holes 1 and Y	50
Holes P and C Aligned with Holes 1 and Z	40
Holes P and C Aligned with Holes 2 and Y	30
Holes P and C Aligned with Holes 2 and Z	20

4. Maintenance

An occasional cleaning of the glass improves the solar panel's efficiency.

If a problem with the solar panel is suspected, the panel may be checked by measuring the voltage output. Check the voltage with a voltmeter connected between the two leads of the solar panel. There must be solar radiation incident on the panel and there must be a load connected to the solar panel. The load can be the datalogger, other equipment, or a 75 ohm resistor capable of dissipating solar panel power between the two leads. No voltage output implies a bad solar panel, regulator, or cable. The magnitude of the voltage output depends on the incident solar radiation.

5. Power Considerations

5.1 Solar Power and Lead Acid Batteries

The solar panel converts light energy to electricity, or specifically direct current. The direct current produced is used as a charging source for lead acid batteries.

The solar panel operates in both direct and diffuse light (cloudy days), but not at night.

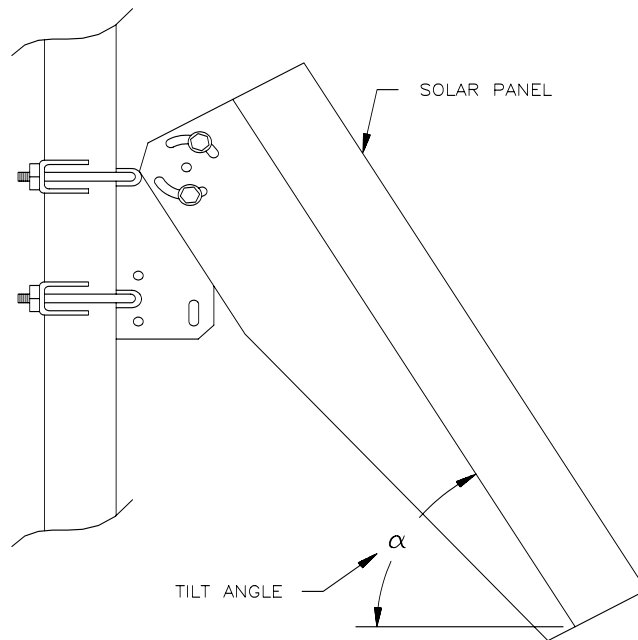

FIGURE 4. Solar Panel Orientation

The minimum battery size and solar panel output required depends on 1) the average current drain of the system, 2) the maximum time the battery must supply power to the system without being charged, and 3) the location of the site. When some batteries are discharged below a specified voltage, the battery becomes damaged and cannot be recharged.

The battery supplies power directly to the operating system, the solar panel supplies power to recharge the battery. Therefore, on the average, the solar panel must provide at least as much power to the battery as is being used by the system.

The battery must have enough capacity to power the system during times of no charging (night) or low charging (stormy winter days).

5.2 Voltage Regulator

The solar panel must be regulated either with a Campbell Scientific regulator or an attached regulator. The regulator has two basic functions: 1) blocks any current flow from the battery to the solar panel, and 2) limits the source current to the battery.

The MSX10 is unregulated and must be connected to a Campbell Scientific voltage regulator. These regulators include the PS100, PS12LA, PS512M, CH12R, CH512R, CR23X rechargeable base, 21XL base, CR200 series dataloggers, and the CR7 solar panel input.

The MSX10R, MSX20R, MSX64R, and MSX128R have a voltage regulator attached. These panels are connected directly to a battery.

Appendix A. Solar Panel Connector

The MSX10 solar panel is shipped standard with the two lead wires stripped and tinned. Item #788 connector must be attached to use the MSX10 with the 21XL.

With the connector, the cable can be inserted directly into the 21XL Charging Port on the side of the Micrologger.

If it is necessary to solder the connector on the cable, please refer to the diagram below.

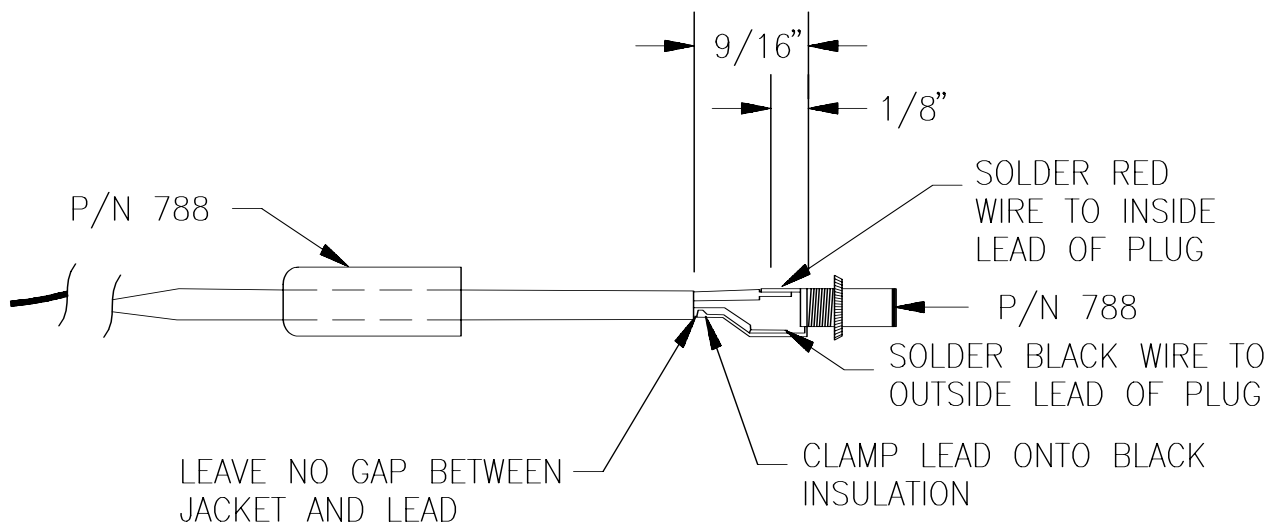

FIGURE A-1. Connector Wiring

Appendix B. Assembly Instructions for 64 Watt Solar Panel with Mounting Bracket

1. ATTACH #2 AND #3 TO PANEL(#1) AS SHOWN USING #10 6,8 AND 7 IN (2) PLCS.
2. ATTACH #4 TO #2 AND #3 IN HOLES FOR DESIRED ANGLE USING #10, 6 (2), 8 AND 7 IN (4) PLCS.
3. WITH BRACKETS FASTENED TOGETHER YOU MAY NOW ATTACH TO STRUCTURE.
4. IF YOU ARE MOUNTING TO A TOWER STRUCTURE, THE (4) #9 U-BOLTS WITH #5 SPACERS ARE TO BE USED.
5. IF YOU ARE MOUNTING TO A MAST OR SINGLE POLE, (2) #11 ARE TO BE USED WITH #6,7 AND 8.

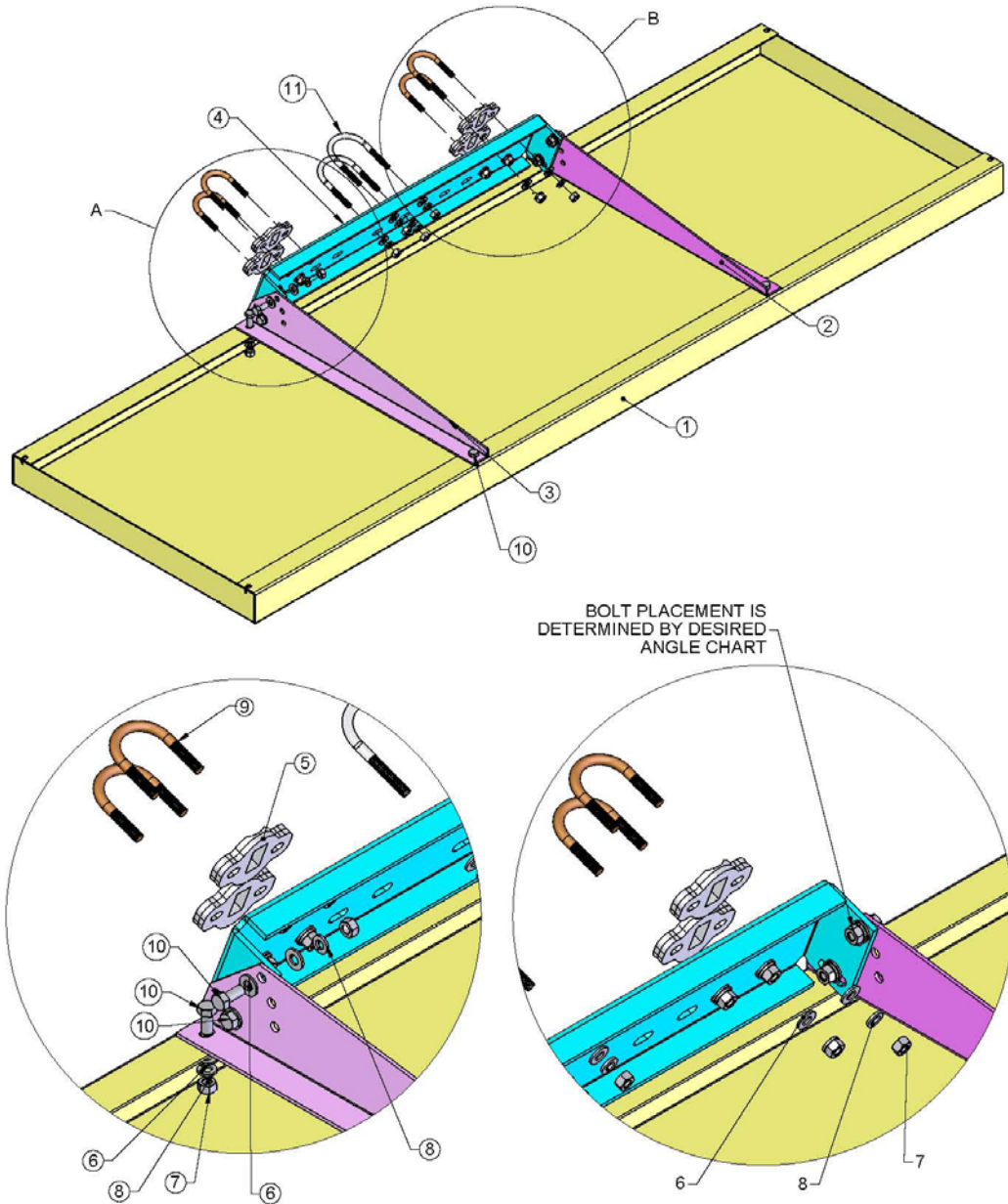

FIGURE B-1. 64 Watt Solar Panel Assembly Instructions

TABLE B-1. Mounting Bracket Parts List		
Item #	Description	Qty
1	64W Solar Panel	1
2	Right Arm Bracket	1
3	Left Arm Bracket	1
4	Mount	1
5	Spacer	4
6	Flat Washer	24
7	5/16-18 Nut	8
8	Lock Washer	20
9	5/16-18 x 1.50 U-Bolt w/nuts	4
10	5/16-18 x .750 Hex Bolt	8
11	5/16-18 x 2.0 U-Bolt w/nuts	2

Campbell Scientific Companies

Campbell Scientific, Inc. (CSI)

815 West 1800 North
Logan, Utah 84321
UNITED STATES
www.campbellsci.com
info@campbellsci.com

Campbell Scientific Africa Pty. Ltd. (CSAf)

PO Box 2450
Somerset West 7129
SOUTH AFRICA
www.csafrica.co.za
sales@csafrica.co.za

Campbell Scientific Australia Pty. Ltd. (CSA)

PO Box 444
Thuringowa Central
QLD 4812 AUSTRALIA
www.campbellsci.com.au
info@campbellsci.com.au

Campbell Scientific do Brazil Ltda. (CSB)

Rua Luisa Crapsi Orsi, 15 Butantã
CEP: 005543-000 São Paulo SP BRAZIL
www.campbellsci.com.br
suporte@campbellsci.com.br

Campbell Scientific Canada Corp. (CSC)

11564 - 149th Street NW
Edmonton, Alberta T5M 1W7
CANADA
www.campbellsci.ca
dataloggers@campbellsci.ca

Campbell Scientific Ltd. (CSL)

Campbell Park
80 Hathern Road
Shepshed, Loughborough LE12 9GX
UNITED KINGDOM
www.campbellsci.co.uk
sales@campbellsci.co.uk

Campbell Scientific Ltd. (France)

Miniparc du Verger - Bat. H
1, rue de Terre Neuve - Les Ulis
91967 COURTABOEUF CEDEX
FRANCE
www.campbellsci.fr
campbell.scientific@wanadoo.fr

Campbell Scientific Spain, S. L.

Psg. Font 14, local 8
08013 Barcelona
SPAIN
www.campbellsci.es
info@campbellsci.es