

SDM-SW8A

Eight-Channel Switch Closure Module



The SDM-SW8A is an 8-channel pulse count module. Each channel can be individually configured for single-pole double-throw (SPDT), single-pole single throw (SPST), or voltage pulse measurements. Output options include state, duty cycle, or counts. The SDM-SW8A is well suited for use in energy management studies.

SDM Operation

The datalogger enables individual modules through an addressing scheme; multiple SDMs (in any combination) can be connected to one datalogger. We recommend a maximum of four SDM-SW8As be connected to a single datalogger. After a module is enabled, it operates independently of the datalogger until additional commands are received or results are transmitted.

Datalogger Connection

The CABLE5CBL-L is recommended for connecting the module to the datalogger. A 1-ft cable length should be sufficient when both datalogger and SDM-SW8A are housed within an ENC12/14 enclosure; a 2-ft length may be required if the datalogger and SDM-SW8A are housed at opposite ends of an ENC16/18 enclosure.

The cable length should be as short as possible. Typically, the maximum cable length is 20 ft. Contact Campbell Scientific if the length needs to be longer.

Power Supply

Due to the 3 mA continuous and 6 mA active current drain, an auxiliary 12 Vdc power supply is recommended for powering the SDM-SW8A in remote, long term applications. Connections between an SDM-SW8A and an auxiliary power supply are shown in the illustration.

For some applications, it may be convenient to use the datalogger power supply. Connection to a datalogger power supply is shown as a dashed line. For long-term applications where ac power is available, or where a solar panel can be used for recharging, the sealed rechargeable power supply available with Campbell Scientific dataloggers could be used. For short term applications only, the alkaline power supply available with Campbell Scientific dataloggers could be used to power the SDM-SW8A.

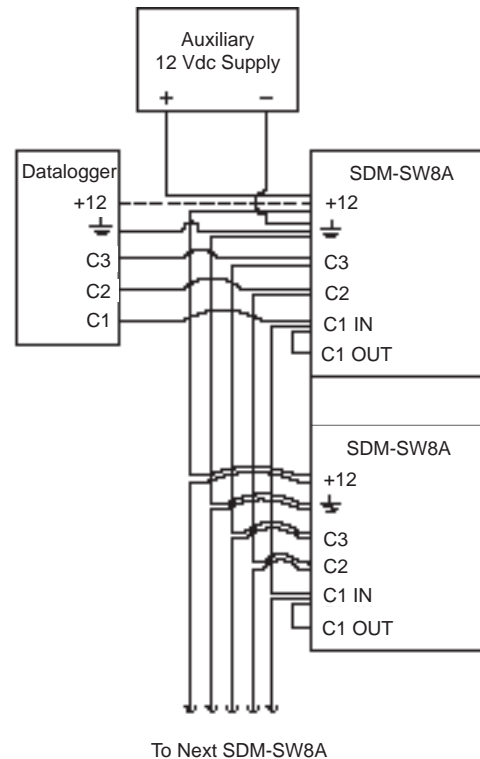
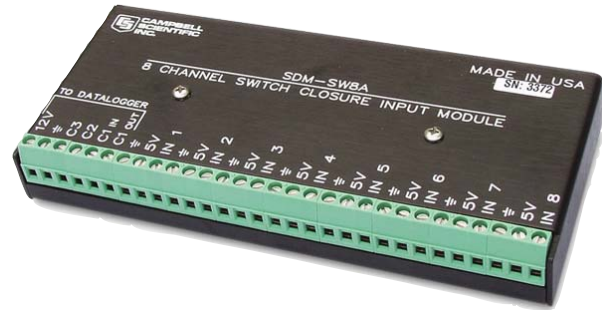

Ordering Information

Synchronous Device for Measurement

SDM-SW8A 8-Channel Switch Closure Input Module

SDM-to-Datalogger Cable

CABLE5CBL-L 5-conductor, 24 AWG cable with drain wire and Santoprene jacket. Enter cable length, in feet, after the -L. Must choose a cable termination option (see below).

Cable Termination Options (choose one)

- PT** Cable terminates in stripped and tinned leads for direct connection to a datalogger's terminals.
- PW** Cable terminates in connector for attachment to a prewired enclosure.

Specifications

Compatible Dataloggers: CR800, CR850, CR1000, CR3000, CR5000, CR7, CR10(X), CR23X, and 21X. The SDM-SW8A is not compatible with the CR200-series, CR9000(X), CR500, and CR510 loggers..

Measurement

Measurement Types: switch closure (SPDT, SPST) dc voltage pulse

Input Voltage Threshold: from below 0.9 to above 4.0 Vdc, ± 20 Vdc maximum.

Maximum Input Frequency: 100 Hz (50% duty cycle)

Minimum Input Pulse Width: 5 ms high, 5 ms low

Maximum Bounce Time: 3 ms open without counting

Output Options: state, duty cycle, counts

Maximum Count/Port: 65535

Internal Sampling Frequency: 500 Hz

Watchdog Reset: yes

Power Requirements

Operating Voltage: 12 Vdc nominal (9.6 V to 16 V)

Typical Current Drain

Quiescent: 3 mA

Active (maximum): 6 mA

Environmental

Operating Temperature: -25° to +55°C

Relative Humidity: 0 to 90% RH, non-condensing

Physical

Size: 6.2 in. x 2.7 in. x 0.9 in;
15.7 cm x 6.9 cm x 2.3 cm)

Weight: 0.5 lbs. (0.23 kg)

