

CS140

Background Luminance Sensor



Table of contents

1. General information	1
1.1 General safety	1
1.2 Sensor unit safety	1
1.3 Recommended tools	1
2. Product overview	2
3. Specifications	2
3.1 Optical specifications	3
3.2 Electrical specifications	3
3.3 Communications specifications	3
3.4 Environmental specifications	4
3.5 Mechanical specifications	5
3.6 Calibrator specifications	5
4. Installation	6
4.1 Location and orientation	6
4.2 Grounding	6
4.3 Mounting	7
4.4 Connectors	8
4.5 Wiring using supplied Campbell Scientific cables	9
4.6 Maintenance cable	9
4.7 Storage information	10
5. Message structure	10
6. Interface methods	14
6.1 Command line menu	14
6.2 Configuring computer	15
6.3 Variable definitions	15
6.4 Command line mode	18
6.4.1 SET command	19
6.4.2 SETNC command	20
6.4.3 GET command	20
6.4.4 Poll command	22

6.5 Menu system	23
7. Calibration	27
8. OS update	30
9. Maintenance	32
9.1 General	32
9.2 Cleaning	33
Appendix A. Example C code of the CCITT CRC	34

1. General information

1.1 General safety

This manual provides important safety considerations for the installation, operation and maintenance of the CS140. These safety considerations are classified into three levels:

WARNING:

Warnings alert the installer or user to serious hazards. Ignoring these warnings could result in injury or death and/or irrevocable damage to the sensor unit.

CAUTION:

Cautions warn of potential hazards. Ignoring these cautions could result in the sensor being damaged and data being lost.

NOTE:

Notes highlight useful information in the installation, use and maintenance of this product. These should be followed carefully in order to gain the maximum benefit from the use of this product.

1.2 Sensor unit safety

The CS140 sensor has been checked for safety before leaving the factory and contains no internally replaceable or modifiable parts.

WARNING:

Do not modify the CS140 unit. Such modifications will damage of the unit.

1.3 Recommended tools

The following tools are recommended for installation:

- 10 mm open spanner/wrench (for grounding boss, must be open)
- 13 mm spanner/wrench

2. Product overview

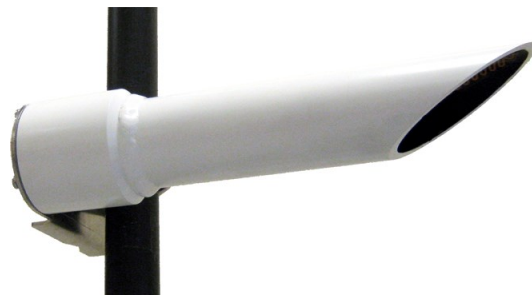

Figure 2-1. CS140 Background Luminance sensor

The CS140 Background Luminance Sensor provides the luminance data required to assess the visibility range for lights such as runway lights or warning lights. It accurately measures background luminance over a wide range from 0 cd/m², to a maximum of 45,000 cd/m². The CS140 uses a photodiode with a spectral response close to the CIE human eye model and removes any unwanted wavelengths via an inbuilt band-pass filter.

The CS140 features a fixed 6° field of view as specified by the FAA. For easy installation, the CS140 is mounted horizontally with the required 6° inclination built into the design. (Other angles are possible via the sensors mounting bracket.)

A heated hood will prevent ice and snow from building up, dew heaters will prevent condensation on the glass window, and a dirty window detection system measures window contamination.

The sensor is undamaged when pointed directly at the sun, allowing complete flexibility in orientation. In addition, the sensor has a rugged IP66 rated environmental enclosure that protects it from the harshest conditions and will measure the atmosphere with high stability and repeatability.

3. Specifications

3.1 Optical specifications	3
3.2 Electrical specifications	3
3.3 Communications specifications	3
3.4 Environmental specifications	4

3.5 Mechanical specifications	5
3.6 Calibrator specifications	5

3.1 Optical specifications

Accuracy:	$\pm 0.2 \text{ cd/m}^2 < 2 \text{ cd/m}^2, \pm 10\% > 2 \text{ cd/m}^2$
Field of view:	6°
Spectral response:	CIE 1931
Measurement range:	0 to 45,000 cd/m^2
Resolution:	0.1 cd/m^2

3.2 Electrical specifications

	Minimum value	Nominal value	Maximum value
Main power supply for DSP and dew heater			
Power supply, DC only	9 V	12 V	30 V
Current consumption, sampling continuously (at 12 V)	5 mA	7 mA	9 mA
Current consumption, sampling continuously with dew heater active (at 12 V)	90 mA	95 mA	100 mA
Hood heater power supply			
Hood heater voltage (AC or DC)	–	24 V	30 V
Hood heater power (at 24 V AC or DC)	–	48 W	55 W

3.3 Communications specifications

Supported serial setting:	8 bits, no parity, 1 stop bit (default)	
Supported data rates:	1200 baud	38400 baud (default)
	2400 baud	57600 baud
	9600 baud	115200 baud
	19200 baud	
Supported standards:	RS-232 (full duplex, no hardware handshaking)	
	RS-485 half duplex	

Signal voltage levels:

	Minimum value	Nominal value	Maximum value
RS-232 communications			
RS-232 input threshold low	0.8 V	1.5 V	–
RS-232 input threshold high	–	2.0 V	2.4 V
RS-232 input absolute maximum	–15 V	–	+15 V
RS-232 input resistance	12 K Ω	–	–
RS-232 output voltage low	–	–	0.4 V
RS-232 output voltage high (into 3 K Ω)	4.4 V	–	–
RS-485 communications			
RS-485 input threshold voltage	–0.2 V	–	+0.2 V
RS-485 output (unloaded)	–	–	5V
RS-485 output (load 50 Ω)	2 V	–	–
Maximum voltage at any terminal	–7 V	–	+7 V

3.4 Environmental specifications

Temperature ranges

Operating:	–25 to +60 °C
Extended operating:	–40 to +70 °C (only guaranteed if sensor has been tested and verified by Campbell Scientific to operate over this range)
Storage:	–40 to +85 °C

Sensor heater thresholds

Dew heater turn on:	<35°C
Dew heater turn off:	>40°C
Hood heater turn on:	<5°C
Hood heater turn off:	>15°C
Ingress protection:	IP66

3.5 Mechanical specifications

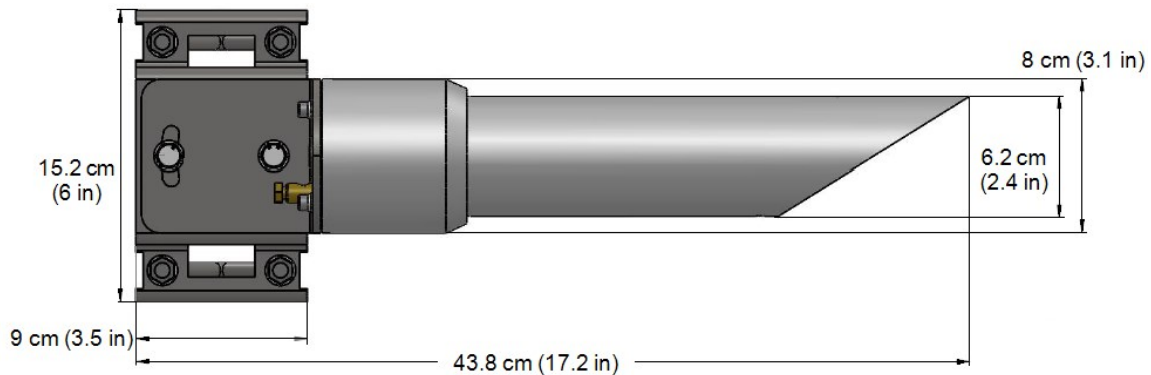

Figure 3-1. CS140 dimensions

Weight: 2.4 kg (5.3 lb)

Shipping weight: 3.5 kg (7.7 lb)

3.6 Calibrator specifications

Temperature range: 0 to 40 °C

Calibration value: 4,500 cd/m²

Accuracy: ±6%

Ingress protection: IP52

Communication: RS-232, 38400 baud (connecting the calibrator to the CS140 forces communications to RS-232, 38400 baud, and the sensor ID to 0.)

Dimensions (excluding cables): 7.2 cm (2.8 in) long, 4.6 cm (1.8 in) diameter

Weight: 300 g (10.5 oz)

4. Installation

4.1 Location and orientation	6
4.2 Grounding	6
4.3 Mounting	7
4.4 Connectors	8
4.5 Wiring using supplied Campbell Scientific cables	9
4.6 Maintenance cable	9
4.7 Storage information	10

4.1 Location and orientation

The CS140 is designed for harsh weather conditions and sunlight shining directly into the CS140 does not damage it. However there are a few considerations to take into account if accurate and representative data from a site are to be obtained.

The CS140 should be placed away from contamination sources. More frequent maintenance is required when the instrument is placed in areas where contamination is unavoidable or where measurements may be safety related.

Point the CS140 towards the desired luminance sources. Ensure that only the light sources in which you are interested are within the sensor field of view. The center of the field of view is 6° above horizontal. The mounting bracket can adjust by ±12° if the mast is not vertical or if it is necessary to elevate the field of view at an angle other than 6°.

4.2 Grounding

The CS140 must be properly grounded with a ground wire that has a minimum cross sectional area of 6 mm² and maximum length of 5 m from the brass grounding lug at the rear of the unit to an adequate grounding point. The pole and foundations of a pole-mounted installation will also provide some basic lightning protection and protection against radio frequency interference when correctly grounded.

4.3 Mounting

A pole mounting kit is supplied with the CS140. This kit includes a mounting plate, two V-bolts and suitable bolts for clamping the pole between the plate and brackets.

To mount the CS140 onto a pole:

1. The mounting plate is supplied ready fixed to the CS140. Line up the plate to the pole and insert the brackets and bolts from the other side of the pole to fit into the matching holes of the plate as in the following figure.

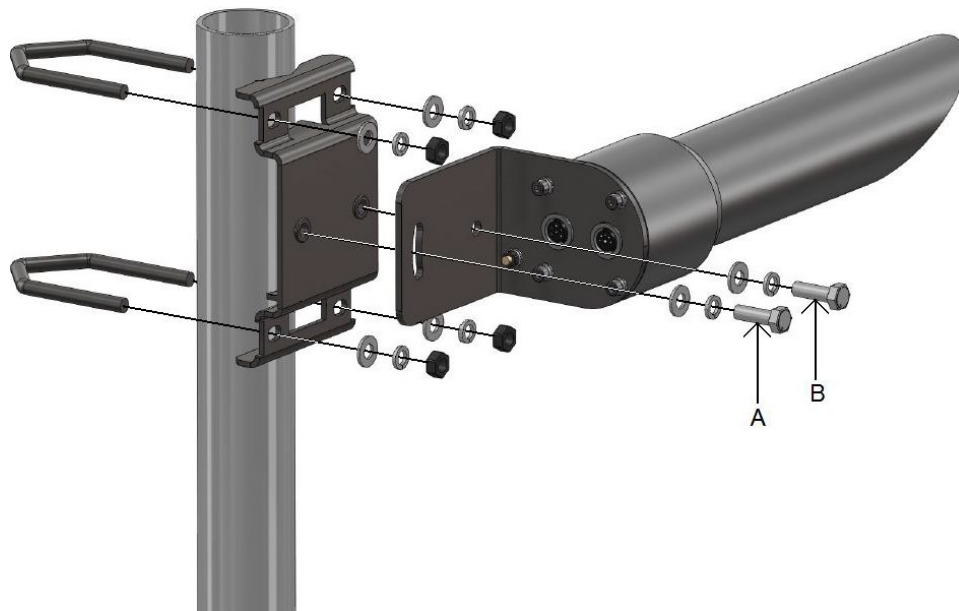

Figure 4-1. CS140 mounted on pole

2. Clamp the pole between the plate and brackets by tightening using the nuts provided.

The machine screws A and B in [Figure 4-1](#) (p. 7) are used to level the CS140. Screw A is used to lock the CS140 at the right elevation with screw B acting as a pivot. Usually, this will be with the hood horizontal which gives a field of view elevated by 6°.

CAUTION:

Do not overtighten the nuts because this may distort or damage the brackets, and cause the nuts to seize up. Only tighten the nuts enough to hold the CS140 firmly in place.

CAUTION:

Do not reposition once nuts are tightened. Forcing the sensor to a different position after tightening the nuts can damage the sensor or bracket.

4.4 Connectors

The CS140 has two connectors. One connector supports communications and supplies power to the sensor. The other connector provides power to the hood heater.

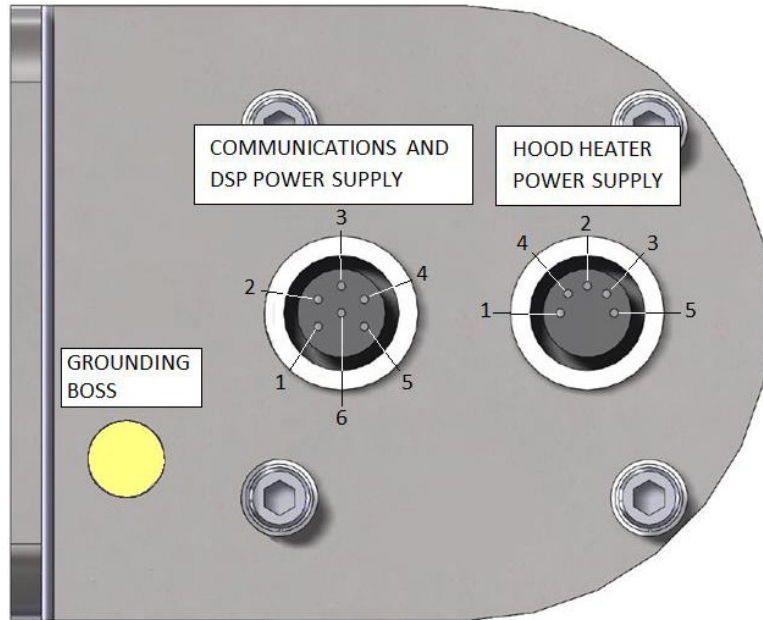

Figure 4-2. Connector layout

Figure 4-3 (p. 8) shows the pin-outs of the sockets viewed from outside. Colors shown are the colors of the cores in the supplied cables.

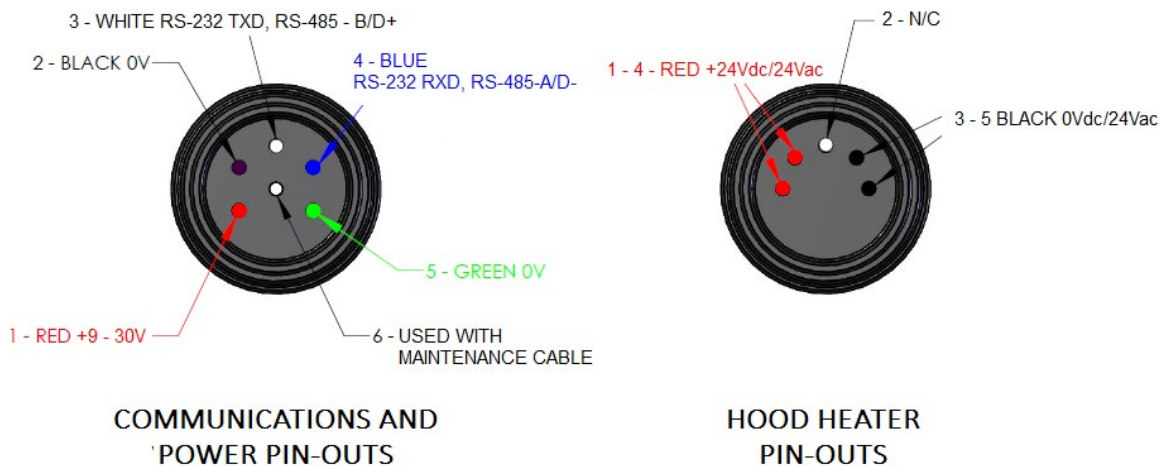

Figure 4-3. Connector pin-outs

4.5 Wiring using supplied Campbell Scientific cables

Two 5 m cables are shipped with the CS140. One cable supports communications and supplies power to the sensor. The other cable provides power to the hood heater.

CAUTION:

Incorrectly wiring the communications/power cable to the CS140 can irrevocably damage the unit.

At one end, the communications cable terminates with a 9-pin D-connector (DB9). The D-connector can be connected directly to a computer or data logger such as the Campbell Scientific CR1000X using a suitable interconnecting cable such as the SC110. If another type of connection is required, the D-connector can be easily removed.

NOTE:

The maximum recommended cable length is 10 m. Use a twisted pair cable if the RS-485 cable needs to be longer than 10 m. Please contact Campbell Scientific if you need a longer cable.

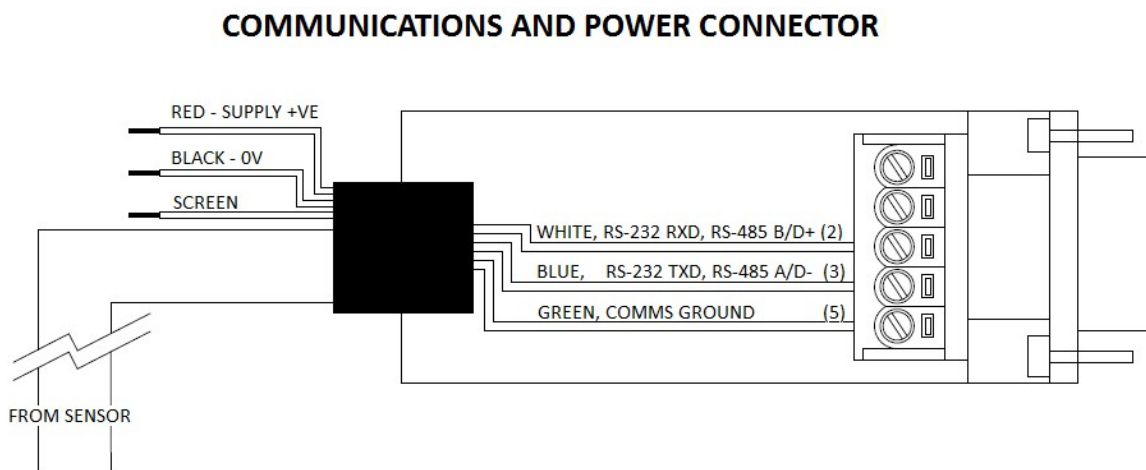

Figure 4-4. Cable connections

4.6 Maintenance cable

Campbell Scientific offers a maintenance cable that will force communications to RS-232, 38400 baud, and sensor id to 0. The cable connectors allow it to be put in between the CS140 and the existing connection and a 5 m flying lead with a 9-way D connector for RS-232 communication.

The sensor will continue to draw power from the existing source. When installed, the existing communication path is disconnected and communication using the flying lead is forced to RS-232, 38400 baud with a sensor ID of 0. When the maintenance cable is removed and replaced with the cable previously used the baud rate and ID will return to those previously set.

CS140 MAINTENANCE CABLE

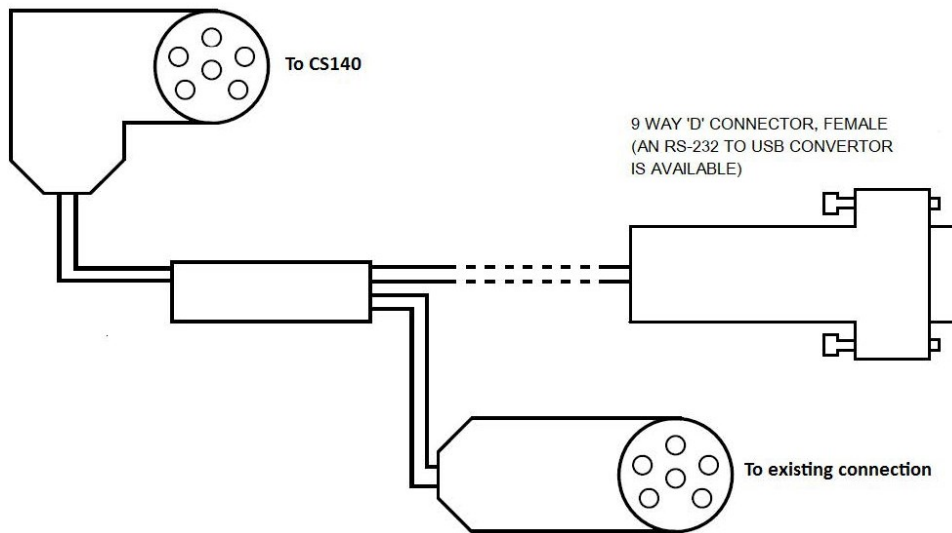

Figure 4-5. Maintenance cable

4.7 Storage information

The CS140 should be stored between -40 to 85 °C in a dry place. The optics should be protected from possible accidental damage.

5. Message structure

STX	Message ID	Sensor ID	System Status	Luminance	Units	Checksum (CCITT)	ETX	Carriage return	Line feed
0x02	0	0	3	35833.7	1	4E7C	0x03	0x0D	0x0A

Example basic format output:

```
0 0 3 35833.7 1 4E7C
```

Table 5-2: Partial Format

STX	Message ID	Sensor ID	System Status	Message Interval	Luminance	Units	User alarms	Checksum (CCITT)	ETX	Carriage return	Line feed
0x02	1		3	10	15732.2	1	0 0 0 0	1ED9	0x03	0x0D	0x0A

Example partial format output:

```
1 0 3 10 15732.0 1 0 0 0 0 1ED9
```

Table 5-3: Full Format

STX	Message ID	Sensor ID	System Status	Message Interval	Luminance	Units	Average duration	User alarms	System alarms	Checksum (CCITT)	ETX	Carriage return	Line feed
0x02	2	0	3	10	15292.4	1	1	0 0 0 0	1 0 3 0 0 0 0 0	F8DA	0x03	0x0D	0x0A

Example full format output:

```
2 0 3 10 15292.4 1 1 0 0 0 0 1 0 3 0 0 0 0 0 0 F8DA
```

Table 5-4: Message ID break down

ID	Definition
0	Basic format. Contains only luminance and system information
1	Partial format. Contains user alarm outputs
2	Full format. Contains all system alarms codes

Table 5-5: Sensor ID break down

ID	Definition
0 to 9	Unit number defined by the user to aid identification of data. Default is 0. Useful for RS-485 networks. Operates as an address in RS-485 mode.

Table 5-6: System status break down^{1,2}

Status level	Definition
0	Basic format. Contains only luminance and system information
1	Partial format. Contains user alarm outputs
2	Full format. Contains all system alarms codes

¹System status break down reflects the highest level of severity of any active alarm.

²Refer to the individual alarms (below) for details of the response times of the alarms.

Table 5-7: Message interval

Time	Definition
1 to 3600	The amount of time, in seconds, between outputs in continuous mode

Table 5-8: Luminance break down

Luminance	Definition
1 to 50000	Current luminance being detected by the sensor. The maximum luminance level reported by the sensor can be defined by the user via the menu system.

Table 5-9: Visibility units break down

Option	Definition
1	cd/m ²
2	fL

Table 5-10: Averaging duration break down

Duration	Definition
1	One minute average
10	Ten minute average

Table 5-11: User and system alarms break down

Alarm	Range	System status	Definition
User Alarm	0 or 1	1	0 = User alarm not active 1 = User alarm active
Spare	–	–	Reserved for future use
Spare	–	–	Reserved for future use
Spare	–	–	Reserved for future use
Window contaminated ¹	0 to 3	0 1 3	0 = OK. The reported attenuation is below 10%. 1 or 2 = Reported dirt level is over 10% 3 = High level of returned dirty signal. This could be either a blocked sensor or a broken dirty window system.

Table 5-11: User and system alarms break down

Alarm	Range	System status	Definition
Photo diode temperature	0 to 3	0 1 1 3	0 = Temperature is within operating conditions. 1 = Too low. Less than -40 °C. 2 = Too high. Over 70 °C. 3 = Sensor fault (No sensor detected or below -49°C)
Hood temperature	0 to 3	0 1 1 2	0 = Temperature is within operating conditions. 1 = Too low. Less than -40 °C. 2 = Too high. Over 70 °C. 3 = Sensor fault (No sensor detected or below -49°C)
Detector DC saturation level ²	0 or 1	0 2	The amount of background light as seen by the detector hood. 0 = Within limits 1 = Saturated. The CS140 is experiencing direct light levels that are saturating the photo diode
Signature error	0 or 1	3	0 = Signature of entire flash was checked and matches the stored version 1 = Signature does not match previous readings
Flash write error	0 or 1	3	0 = No errors 1 = One or more errors reading user variables from flash occurred

Table 5-11: User and system alarms break down

Alarm	Range	System status	Definition
Internal voltages	0 or 1	3	0 = No errors 1 = One or more errors reading user variables from flash occurred
Spare	–	–	Reserved for future use

¹With OS version 9 or newer, this alarm flag will not increase in level until the dirt detector has been above the "dirt" threshold continuously for 15 minutes or more. This prevents transient setting of the flag caused by reflections, insects, or dust.

² With OS version 9 or newer, this alarm flag will not change to level 1 unless the sensor has been continuously saturated for 60 minutes or more. This is to avoid false alarms if the sun shines directly into the sensor.

6. Interface methods

6.1 Command line menu	14
6.2 Configuring computer	15
6.3 Variable definitions	15
6.4 Command line mode	18
6.5 Menu system	23

6.1 Command line menu

The CS140 can be setup and controlled in one of two ways. The first method is by using the command line interface where discrete commands are sent without response from the sensor. This method is preferred for setting up a CS140 that is connected to a data logger. The data logger can send configuration setting commands to the CS140 removing the need for a computer to set up the unit.

The second method is by using the simple menu interface built into the CS140 using RS-232 or RS-485 communications and a terminal emulator program. This menu system gives access to the more common settings.

6.2 Configuring computer

This section describes setting up communications using a terminal emulator program. The terminal emulators built into many Campbell Scientific software products such as *LoggerNet* can also be used.

The following settings should then be used by default:

Bits per second: 38400

Data bits: 8

Parity: none

Stop bits: 1 Flow control: none

NOTE:

After adjusting the baud rate of the unit, use the terminal emulator to adjust the bits per second value in the port settings. The CS140 can not communicate with the computer if the unit and port setting baud rates differ.

The CS140 should now be ready to accept commands.

6.3 Variable definitions

The command line interface can access all the following user configurable variables:

ID	Name	Range	Description	Default
1	Sensor ID	0 to 9	Separate ID used as an identifier for a particular CS140 on a network.	0
2	Serial port protocol	0 or 1	Selects the physical serial interface: 0 = RS-232 mode 1 = RS-485 mode	2

Table 6-1: Command line variable definitions

ID	Name	Range	Description	Default
3	Serial baud rate	0 to 6	Baud rate for the main RS-232/RS-485 interface: 0 = 115200 bps 1 = 57600 bps 2 = 38400 bps 3 = 19200 bps 4 = 9600 bps 5 = 2400 bps 6 = 1200 bps	2
4	Serial number (read only)	0 to 32000	Internal serial number	–
5	Luminance units	0 or 1	Units for the CS140 luminance value: 0 = Candela per meters square (cd/m ²) 1 = Foot lamberts (fL)	0
6	Message interval	1 to 3600	Interval, in seconds, between outputs in continuous mode. This value has no effect if the polled mode selected for the Measurement mode (see the following row).	60
7	Measurement mode	0 or 1	Selects polled or continuous modes. In continuous mode, the sensor outputs a string in the format as set by Message Format at regular intervals as defined by Continuous Interval . 0 = Continuous mode 1 = Polled mode	0

Table 6-1: Command line variable definitions

ID	Name	Range	Description	Default
8	Message Format	0 to 2	Level of detail outputted by polled or continuous modes: 0 = Basic 1 = Partial 2 = Full	2
9	Sample timing	1 to 60	Not currently implemented	1
10	Averaging period	1 or 10	The period of time that the luminance value should be averaged over.	1
11	Dew heater override	0 or 1	0 = Allow the CS140 to automatically control the dew heater 1 = Turn the dew heater off	0
12	Hood heater override ¹	0 or 1	0 = Allow the CS140 to automatically control the hood heater 1 = Turn the hood heater off	0
13	Dirty window compensation	0 or 1	0 = No compensation applied 1 = Compensation for dirt on window applied. The CS140 will compensate for up to 10% signal loss due to dirt on the window.	0
14	Use CRC	0 or 1	0 = Disable command line CRC checking ² 1 = Enable command line CRC checking.	0

NOTE:
This does not affect communications using *Device Configuration* utility or terminal emulator.

Table 6-1: Command line variable definitions

ID	Name	Range	Description	Default
15	Power Supply Unit (PSU) voltage level shutdown	9 to 30	PSU input voltage level below which the CS140 will enter low power mode. This helps protect the batteries. NOTE: The CS140 shuts itself down via hardware at about 8 VDC.	9
16	Enable alarm	0 or 1	0 = Alarm off 1 = Alarm on	0
17	Alarm high/low	0 or 1	0 = Alarm triggered by a luminance higher than the alarm level 1 = Alarm triggered by a luminance lower than the alarm level	0
18	Alarm level	0 to 45000	Luminance level, in cd/m ² , that triggers the alarm.	10000

¹ Hood heater override needs to be set to 1 (off) when the hood heater has no power connected. This will save power as the relay is not enabled at low temperatures in this mode.

²If disabled the sensor does not check the validity of received data against the checksum sent. It is, however, recommended that checksum checking is enabled to remove any chance of the CS140 being configured incorrectly by accident.

6.4 Command line mode

The command line interface is broken down into three major commands. These are **GET**, **SET** and **POLL**. The **GET** command is used to request all current user settable values from the CS140. The **SET** commands sets user settable values and the **POLL** command is used to request the current visibility and/or alarm conditions from the sensor.

The CS140 can be configured to expect any commands sent to it to include a valid checksum. For simple commands such as **GET** and **POLL**, fixed value checksums can be used. For more complex **SET** commands the checksum needs to be calculated. The use of the checksum is disabled by default. Campbell Scientific recommends enabling the checksum functionality, especially when long cable runs are used, or in electronically noisy environments. [Example C code of the CCITT CRC](#) (p. 34) provides example code for programmers implementing their own code. For

Campbell Scientific data logger users, downloadable example programs are available at www.campbellsci.com/downloads/cs140-program-examples.

6.4.1 SET command

The **SET** command is used to configure the CS140 using the command line. The **SET** command is a single space delimited string that can be sent from any data logger or computer equipped with an RS-232 or RS-485 port. The **SET** command accesses identical settings within the CS140. This command is used to change the default power up state of the sensor. The **Set** command is echoed back.

Example of a **SET** command and the echoed reply:

```
SET: 0:0 0 2 0 0 10 1 2 1 1 0 0 0 1 9.5 0 0 10000 :E52F:
0 0 2 1000 0 10 1 2 1 1 0 0 0 1 9.5 0 0 10000 0146
```

Table 6-2: SET transmitted/echoed data

Example	Description
0x02 ¹	STX
:	Delimiting character
SET	Set command
:	Delimiting character
0	Address based on sensor ID
:	Delimiting character
0	Sensor ID
2	Serial port protocol
0	Serial baud rate
1000	Sensor serial number (only in echoed reply)
0	Luminance units
10	Continuous mode output interval
1	Polling or continuous modes
2	Message format (basic/partial/full)
1	Averaging period
1	Sample timing
0	Dew heater override

Example	Description
0	Hood heater override
0	Dirty window compensation
1	CRC checking on received commands
9.5	Sensor power down voltage
0	Enable alarm
0	Alarm high/low
10000	Alarm level
:	Delimiting character
0146	Checksum (use the valid CCITT checksum)
:	Delimiting character
0x03 ¹	ETX
0x0D ¹	Carriage return

¹These values are shown in hexadecimal format not ASCII.

6.4.2 SETNC command

The format of the **SETNC** command is the same as the **SET** command except it starts with **SETNC**. The only functional difference is that the **SETNC** command does not commit the values set into flash memory. This means that the next time the CS140 is power cycled it will revert back to its previous settings. This command should be used when a setting in the sensor is changed regularly, e.g. heater functions, as this command avoids the risk of wearing out the flash storage memory.

NOTE:

This includes communication data rates as well.

6.4.3 GET command

The **GET** command retrieves settings data from the CS140, including message format data and user alarm settings amongst others. This command does not retrieve visibility or environmental information from the CS140. To retrieve visibility data refer to the **POLL** command.

Table 6-3: GET command transmitted data

Example	Description
0x02 ¹	STX
GET	GET command
:	Delimiting character
0	Address based on sensor ID
:	Delimiting character
0	Reserved for future use; zero default
:	Delimiting character
2C67	Checksum
:	Delimiting character
0x03 ¹	ETX
0x0D ¹	Carriage return

¹ These values are shown in hexadecimal format not ASCII.

Example of a GET request:

```
GET : 0 : 0 : 2C67 :
```

Example data returned by the GET command:

```
GET : 0 : 0 : 2C67 :  
0 0 2 1000 0 60 0 2 1 1 0 0 0 1 7.0 0 0 10000 626C
```

Table 6-4: GET command returned data

Example	Description
0x02 ¹	STX
0	Sensor ID
0	Serial port protocol
2	Serial baud rate
1000	Sensor serial number (read only)
0	Luminance units
60	Continuous mode output interval

Table 6-4: GET command returned data	
Example	Description
0	Polling or continuous modes
2	Message format (Basic/Partial/Full)
1	Averaging period
1	Sample timing
0	Dew heater override
0	Hood heater override
0	Dirty window compensation
1	CRC checking on received commands
7.0	Sensor power down voltage
0	Enable alarm
0	Alarm high/low
10000	Alarm level
:	Delimiting character
626C	Checksum
:	Delimiting character
0x04 ¹	EOX
0x0D ¹	Carriage return
0x0A	Line feed

¹ These values are shown in hexadecimal format not ASCII.

6.4.4 Poll command

The **POLL** command requests the current visibility and/or alarm conditions from the CS140. The output format of this command depends on how the CS140 is configured using the **SET** command or the menu interfaces.

Example of a **POLL** request with returned message:

```
POLL : 0 : 0 : 3 A3B:
2 0 0 60 22.9 1 1 0 0 0 0 0 0 0 0 0 0 0 0 5EC7
```

Example	Description
0x02 ¹	STX
POLL	POLL command
:	Delimiting character
0	Address based on sensor ID
:	Delimiting character
0	Reserved for future use; zero default
:	Delimiting character
3A3B	Checksum
:	Delimiting character
0x03 ¹	ETX
0x0D ¹	Carriage return

¹ These values are shown in hexadecimal format not ASCII.

6.5 Menu system

When connected to the CS140, the user can enter the menu system by typing **open id** in their terminal program then pressing the return key on their keyboard. The ID corresponds to the sensor ID number. The sensor ID number can be in the range of 0 to 9. The factory default is 0.

NOTE:

The **open 0** command is not normally echoed. The terminal menu only gives access to more common settings.

The following text will now be displayed:

```
WELCOME TO THE CAMPBELL SCIENTIFIC LTD CS140 SETUP MENU
ID 0
S/N 1009
(1) Message output menu
(2) User alarm menu
(3) Communications setup
(4) System information
(5) System configuration
(6) Calibration

(9) Exit and save
(0) Exit and don't save
```

The displayed options are accessed simply by typing the corresponding number then pressing return. No changes will take effect until you **Exit and Save**. The exception to this is the calibration menu, but you will be informed before any changes are made.

The displayed options are accessed simply by typing the corresponding number then pressing return. No changes will take effect until you **Exit and Save**. The exception to this is the calibration menu, but you will be informed before any changes are made.

Type **1** to open the message menu containing settings relating to the CS140 outputs.

Menu 1: The message output menu:

```
CS140 MENU 1
ID 0
S/N 1009
(1) Toggle message format: FULL
(2) Toggle units: cd/m2
(3) Toggle polled or continuous mode:CONTINUOUS
(4) Set continuous mode output interval: 6 second(s)
(5) Toggle output averaging period: 1 minute(s)
(6) Sampling interval: 1 second(s)

(9) Refresh
(0) Return to main menu
```

For example typing **2** will toggle the units through the options cd/m² and fL and typing **4** will allow the message interval to be entered.

Option (2) allows the user alarms to be set, again by toggling through options or changing values. It also allows the measurement range to be set. Upper and lower limits can be set individually or the CS140 can be set to report between FAA limits (6.85-41115.0 cd/m², 2 to 12000 fL) or UK CAA limits (5-35000.0 cd/m²).

Menu 2: The user alarm menu:

```
CS140 ALARM AND LIMIT MENU 2
ID 0
S/N 1009
(1) Toggle user alarm one: DISABLED
(2) Toggle alarm one threshold: LESS THAN
(3) Set new user alarm one activation point:
    10000 cd/m2
(4) Set upper output limit: 45000 cd/m2
(5) Set lower output limit: 5 cd/m2
(6) Set to FAA limits
(7) Set to CAA limits

(9) Refresh
(0) Return to main menu

->
```

Option (3) gives the communications menu. This is used to set baud rates and the mode of operation (RS-232/RS-485).

NOTE:

No change will take effect until you **Exit and Save**.

Menu 3: The communications menu:

```
CS140 COMMUNICATIONS MENU 3
ID 0
S/N 1009
(1) Set sensor ID
(2) Set RS232/RS485 baud rate: 38400
(3) Toggle RS232/RS485 modes: RS232

(9) Refresh
(0) Return to main menu

->
```

Option (4) gives the systems information menu containing useful information such as temperature and system alarms.

Menu 4: System information menu:

```
CS140 INFORMATION MENU 3
ID 0
S/N 1009
OS version: 7644-07

Alarm      Value
-          3100.0
- Overall system status: 0      No faults
- Detector dirty window alarm: 0      0%
- Sensor internal temperature: 0      28.0
- Hood heater temperature: 0      22.7
- CS140 Rig Constant: -          100
- CS140 Reference Value: -          100.00
- Calibration value Fac offset: -          -33.00
- Calibration value Fac scale: -          30.00
- User Reference Value, cd/m²: -          4500.00
- User calibration value offset: -          19.66
- User calibration value scale: -          332.4
- Signature fault: 0          -
- Flash write errors: 0          0
- Flash read errors: 0          0
- Supply voltage: <9.0V      11.5V
- Aux supply voltages: +5V=5.0  +3V=3.0

(8) Get debug
(9) Refresh
(0) Return to main menu

->
```

If the dirty window alarm is set, clean the sensor as described in [Cleaning](#) (p. 33). If there is a flash error or signature error, contact Campbell Scientific.

The aux supply voltages are internal 5 volt and 3 volt supplies. They should be between 4.5 and 5.5 and 2.7 and 3.3 volts respectively.

Menu option (5) allows configuration of heaters, window compensation, CRC Checking and the power down voltage.

```
CS140 CONFIGURATION MENU 5
ID 0
S/N 1009
(1) Toggle dew heater override: AUTOMATIC
(2) Toggle hood heater override: AUTOMATIC
(3) Toggle dirty window compensation: NO COMPENSATION
(4) Toggle command line CRC Checking: DO NOT CHECK
(5) Sensor power down voltage: 9.0V

(9) Refresh
(0) Return to main menu

->
```

Menu option (6) allows calibration of the CS140 using an optional calibration device. It also allows the user to reset the CS140 to factory default values.

```
CS140 CONFIGURATION MENU 6
ID 0
S/N 1009
(1) Perform a user calibration
(2) Reset the user calibration to factory values

(9) Refresh
(0) Return to main menu

->
```

To perform a calibration chose option (1); see [Calibration](#) (p. 27). Once a calibration is finished changes are immediate, but factory calibrations can be restored if needed using option (2) in the calibration menu.

7. Calibration

The CS140 can be checked and adjusted using the optional calibration device. The calibration must be run using the onboard menu system. If you have Campbell Scientific *Device Configuration* utility program, a terminal emulation screen is provided in the CS140 screens to let you access this function.

To perform the calibration, you will need the calibrator device and a computer with a compatible USB port. The calibrator device is sealed to IP52 and will generate a test light level of 4,500 cd/m² accurate to ±6% over a temperature range of 0 to 40°C.

Campbell Scientific recommends cleaning the window before calibrating the CS140. The system is self-regulating. However, the CS140 should be calibrated at least every two years. The

calibration is performed from menu item 6 on the main terminal screen. Once you have selected menu item 6 you will be presented with the following screen.

```
CS140 CONFIGURATION MENU 6
ID 0
S/N 1009
(1) Perform a user calibration
(2) Reset the user calibration to factory values

(9) Refresh
(0) Return to main menu

->
```

Select option 1 to start the calibration. At this point the calibration device and cable should be installed as shown in the following figures. Connecting the calibrator switches the CS140 to communication at 38400 baud with a sensor ID of 0. This will happen whatever the previous setting or whether the CS140 was set to RS-232 or RS-485.

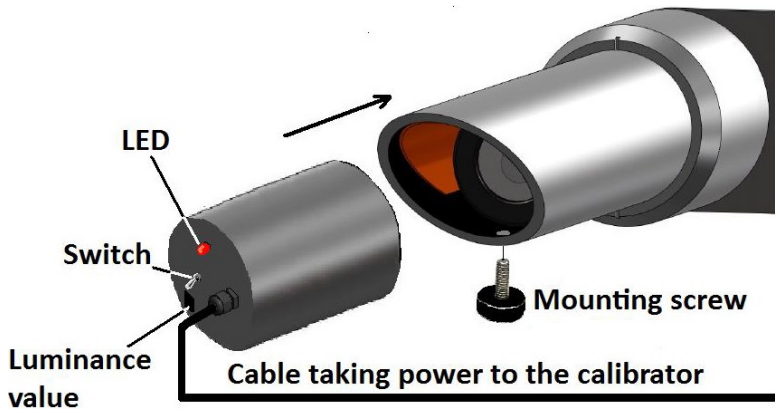

Figure 7-1. Calibrator device

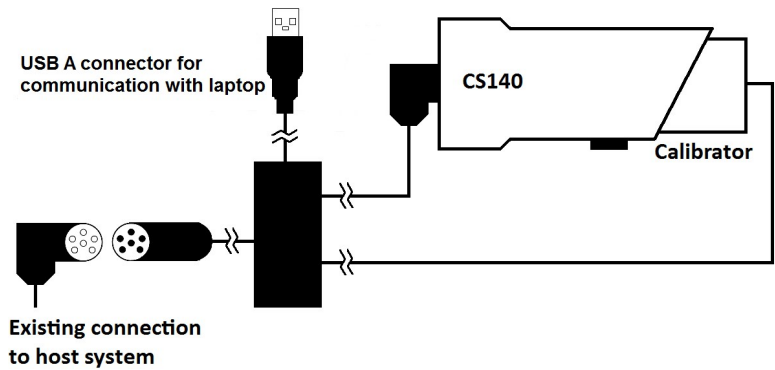

Figure 7-2. Calibrator device connections

The CS140 menu structure will still be available while the calibrator is connected. You will then be asked to confirm that you would like to perform a calibration.

Once you have typed yes, you will not be able to exit until the test is complete. However, power cycling the unit at this point will have no adverse effect on the sensor. After starting the tests, you will be asked for the calibrator device luminance value with a confirmation at each step giving you the chance to correct typing mistakes. The luminance value will be 4500.0 for the calibrator device.

NOTE:

When asked for confirmation, you do not need to press return after you type y.

```
Input the CS140CAL luminance value (cd/m2) -> 4500.0
Is 4500.0 correct? (Y/N)?
Y
Place the CS140CAL into the hood.
Ensure the CS140CAL is turned off, then press any key.
H
Starting dark level calibration.....
Dark level test complete.
```

This part of the test will take approximately two minutes. Every ten seconds a dot should appear indicating that the test is progressing as normal. The CS140 will then ask you to turn on the calibrator device.

```
Turn the CS140CAL on.
Press any key once this is done.
```

Once confirmed the light level calibration will begin.

```
Starting light level calibration. (This will take 5-6
minutes).....
Saving user calibration settings.

Calibration is now complete. You may remove the
CS140CAL at any time.

CS140CAL Val:4500.0 Offset:20.33 Scale:332.0

Press any key to exit.
```

Once the light level calibration has been completed, the new calibration constants will be saved automatically. All calibration constants including both the user and the factory setting can be viewed from menu item (4) from the main menu once the test is completed.

8. OS update

Operating system updates for the CS140 background luminance sensor are performed using Campbell Scientific *Device Configuration Utility* software. This is available as a free download from the Campbell Scientific website. Please refer to the help built into the *Device Configuration Utility* for full instructions on how to update the CS140.

NOTE:

To use the *Device Configuration Utility* to carry out an OS change requires RS-232 communication. However, if a sensor is set to communicate by RS-485, it is not necessary to change this in the sensor.

Connect a computer with the *Device Configuration Utility* running to the sensor with RS-232 communications. Run the *Device Configuration Utility* to the stage shown in [Figure 8-1](#) (p. 31). Then turn on the sensors power supply. The update will then take place through RS-232. The sensor will however remain in RS-485 mode afterwards.

The following figures show the instructions for downloading an OS using the *Device Configuration Utility*.

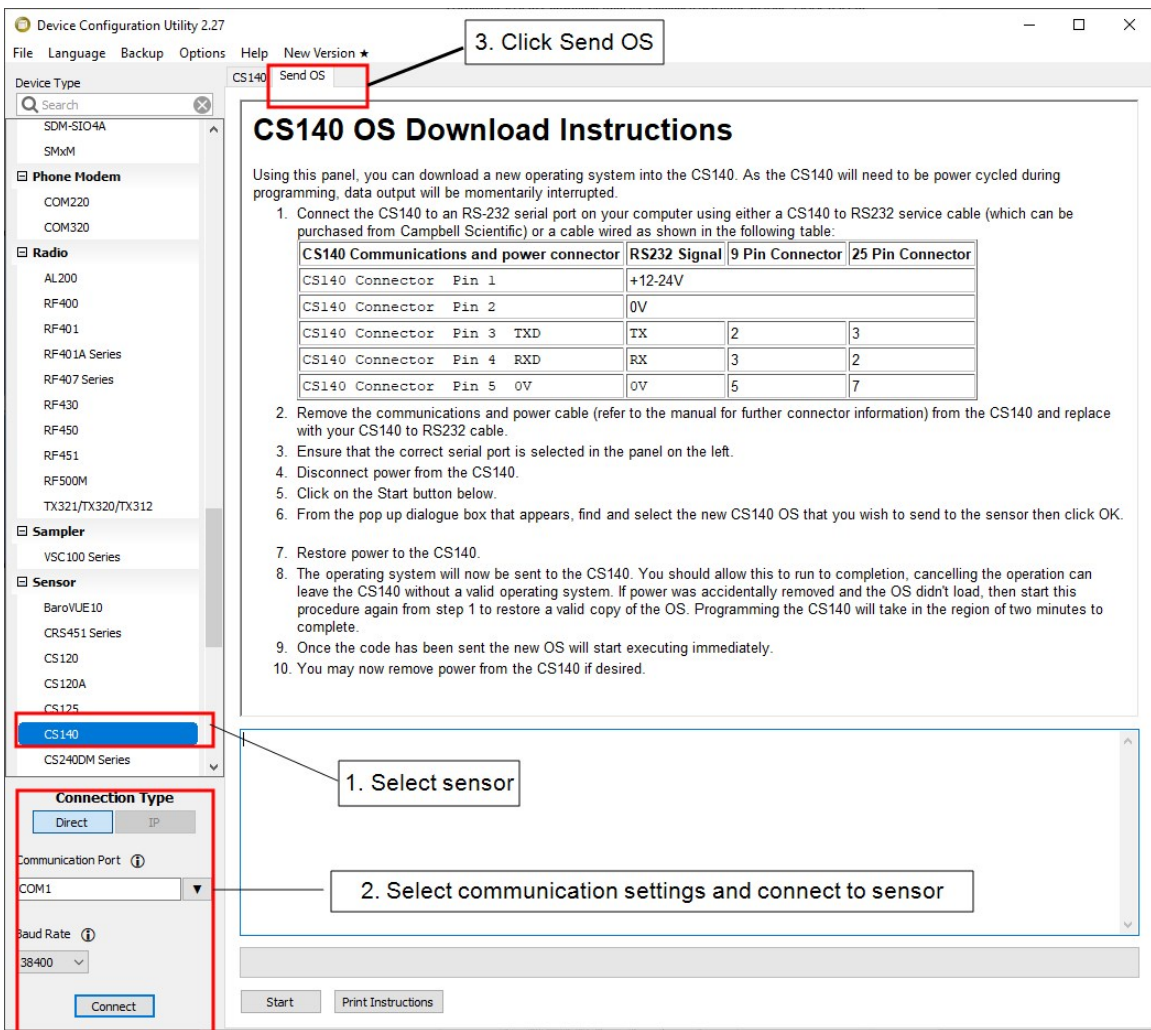

Figure 8-1. CS140 Device Configuration Utility OS download instructions

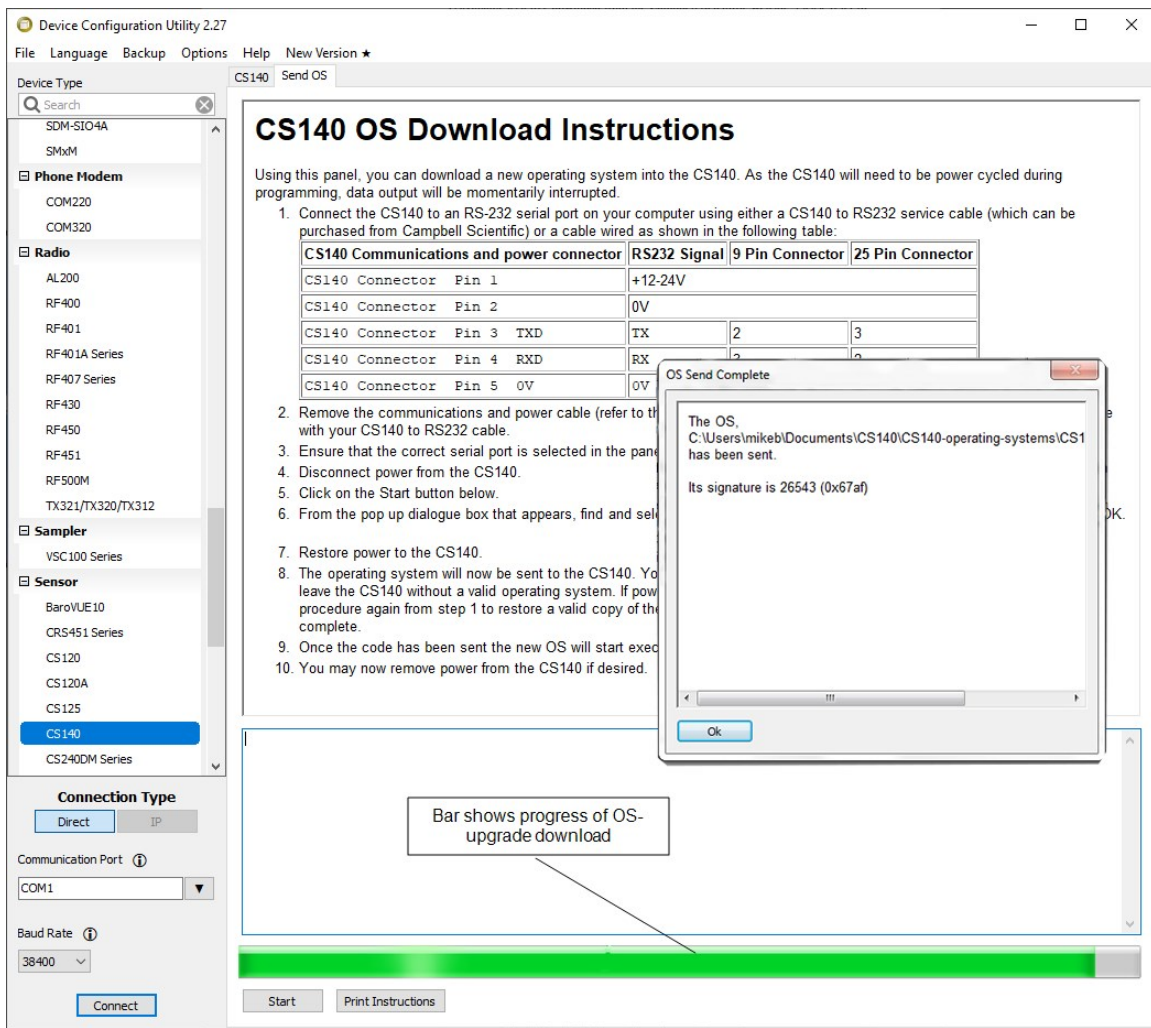

Figure 8-2. Device Configuration Utility screen when OS update is complete

9. Maintenance

9.1 General

The CS140 is a robust weather resistant instrument and there is no need for routine maintenance other than cleaning. The instrument performance is monitored and any potential problems are covered by error messages. Other maintenance is carried out by return to Campbell Scientific.

9.2 Cleaning

The CS140 window will require cleaning from time to time. The frequency of required cleaning depends on the exposure of the instrument to contaminants such as salt and dust. This will vary depending on the site location. The CS140 is capable of self-diagnosing a dirty window and will indicate in its output when the window is contaminated.

Campbell Scientific suggests cleaning at six-month intervals for locations not prone to contaminants and monthly intervals for those prone to contamination (coastal, roadside or airport use). In some cases, more frequent cleaning may be required where there are high levels of contaminants and high dependency on the instrument output.

CAUTION:

If the window requires cleaning, it is very important that only a proper lens cloth or lens tissue is used. The use of inappropriate materials to clean the window can permanently damage or reduce the effectiveness of the window leading to errors in measurement of precipitation and visibility.

It is advisable to use an air duster to blow any loose dust and dirt from the window as a first step. Using a lint-free lens cloth or lens tissue impregnated with a small amount of isopropyl alcohol solvent, clean the surface by dragging the cloth across it being careful not to apply excessive pressure.

CAUTION:

Excessive pressure may lead to some types of contaminant scratching the window surface. Over time such scratches can lead to reduced sensitivity.

Appendix A. Example C code of the CCITT CRC

The following code is provided as an example for programmers implementing their own code to communicate with the sensor. Users using Campbell data loggers can use the checksum command in *CRBasic Editor* to generate a CCITT checksum. Refer to the downloadable example programs available at www.campbellsci.com/downloads/cs140-program-examples .

The checksum includes all characters after the STX and before the space preceding the checksum.

The SET and SETNC commands also exclude the two delimiting : characters, one on each side of the checksum itself.

```
//-----  
// Creates a CCITT CRC16 checksum seeded with 0x0000 (XModem style) using a  
// fast non table based algorithm.  
// Pass in the data to convert into a CRC in the form of a NULL terminated  
// character array (a string).  
// Returns the CRC in the form of an unsigned 16 bit integer value  
// Note: This algorithm has only been tested on a native 16-bit processor with  
// a hardware barrel shifter // All integers are 16-bits long  
//-----  
unsigned int CRC_CCITT(char LineOfData[])  
{  
    unsigned int crc;  
    // returned CRC value unsigned int i;  
    // counter crc = 0x0000;  
    // create a check sum for the incoming data for(i=0;i < strlen(LineOfData); i++)  
    {  
        unsigned crc_new = (unsigned char)(crc >> 8) | (crc << 8);  
        crc_new ^= LineOfData[i];  
        crc_new ^= (unsigned char)(crc_new & 0xff) >> 4;  
        crc_new ^= crc_new << 12;  
        crc_new ^= (crc_new & 0xff) << 5; crc = crc_new;  
    }  
    return(crc);  
}
```

Limited warranty

Products manufactured by Campbell Scientific are warranted by Campbell Scientific to be free from defects in materials and workmanship under normal use and service for two years from the date of shipment unless otherwise specified on the corresponding product webpage. See Product Details on the Ordering Information pages at www.campbellsci.com. Other manufacturer's products, that are resold by Campbell Scientific, are warranted only to the limits extended by the original manufacturer.

Refer to www.campbellsci.com/terms#warranty for more information.

CAMPBELL SCIENTIFIC EXPRESSLY DISCLAIMS AND EXCLUDES ANY IMPLIED WARRANTIES OF MERCHANTABILITY OR FITNESS FOR A PARTICULAR PURPOSE. Campbell Scientific hereby disclaims, to the fullest extent allowed by applicable law, any and all warranties and conditions with respect to the Products, whether express, implied or statutory, other than those expressly provided herein.

Assistance

Products may not be returned without prior authorization.

Products shipped to Campbell Scientific require a Returned Materials Authorization (RMA) or Repair Reference number and must be clean and uncontaminated by harmful substances, such as hazardous materials, chemicals, insects, and pests. Please complete the required forms prior to shipping equipment.

Campbell Scientific regional offices handle repairs for customers within their territories. Please see the back page for the Global Sales and Support Network or visit www.campbellsci.com/contact  to determine which Campbell Scientific office serves your country.

To obtain a Returned Materials Authorization or Repair Reference number, contact your CAMPBELL SCIENTIFIC regional office. Please write the issued number clearly on the outside of the shipping container and ship as directed.

For all returns, the customer must provide a "Statement of Product Cleanliness and Decontamination" or "Declaration of Hazardous Material and Decontamination" form and comply with the requirements specified in it. The form is available from your CAMPBELL SCIENTIFIC regional office. Campbell Scientific is unable to process any returns until we receive this statement. If the statement is not received within three days of product receipt or is incomplete, the product will be returned to the customer at the customer's expense. Campbell Scientific reserves the right to refuse service on products that were exposed to contaminants that may cause health or safety concerns for our employees.

Safety

DANGER — MANY HAZARDS ARE ASSOCIATED WITH INSTALLING, USING, MAINTAINING, AND WORKING ON OR AROUND TRIPODS, TOWERS, AND ANY ATTACHMENTS TO TRIPODS AND tripodS SUCH AS SENSORS, CROSSARMS, ENCLOSURES, ANTENNAS, ETC. FAILURE TO PROPERLY AND COMPLETELY ASSEMBLE, INSTALL, OPERATE, USE, AND MAINTAIN TRIPODS, tripodS, AND ATTACHMENTS, AND FAILURE TO HEED WARNINGS, INCREASES THE RISK OF DEATH, ACCIDENT, SERIOUS INJURY, PROPERTY DAMAGE, AND PRODUCT FAILURE. TAKE ALL REASONABLE PRECAUTIONS TO AVOID THESE HAZARDS. CHECK WITH YOUR ORGANIZATION'S SAFETY COORDINATOR (OR POLICY) FOR PROCEDURES AND REQUIRED PROTECTIVE EQUIPMENT PRIOR TO PERFORMING ANY WORK.

Use tripods, tripods, and attachments to tripods and tripods only for purposes for which they are designed. Do not exceed design limits. Be familiar and comply with all instructions provided in product manuals. Manuals are available at www.campbellsci.com. You are responsible for conformance with governing codes and regulations, including safety regulations, and the integrity and location of structures or land to which tripods, tripods, and any attachments are attached. Installation sites should be evaluated and approved by a qualified engineer. If questions or concerns arise regarding installation, use, or maintenance of tripods, tripods, attachments, or electrical connections, consult with a licensed and qualified engineer or electrician.

General

- Protect from over-voltage.
- Protect electrical equipment from water.
- Protect from electrostatic discharge (ESD).
- Protect from lightning.
- Prior to performing site or installation work, obtain required approvals and permits. Comply with all governing structure-height regulations.
- Use only qualified personnel for installation, use, and maintenance of tripods and tripods, and any attachments to tripods and tripods. The use of licensed and qualified contractors is highly recommended.
- Read all applicable instructions carefully and understand procedures thoroughly before beginning work.
- Wear a **hardhat** and **eye protection**, and take **other appropriate safety precautions** while working on or around tripods and tripods.
- **Do not climb** tripods or tripods at any time, and prohibit climbing by other persons. Take reasonable precautions to secure tripod and tripod sites from trespassers.
- Use only manufacturer recommended parts, materials, and tools.

Utility and Electrical

- **You can be killed** or sustain serious bodily injury if the tripod, tripod, or attachments you are installing, constructing, using, or maintaining, or a tool, stake, or anchor, come in **contact with overhead or underground utility lines**.
- Maintain a distance of at least one-and-one-half times structure height, 6 meters (20 feet), or the distance required by applicable law, **whichever is greater**, between overhead utility lines and the structure (tripod, tripod, attachments, or tools).
- Prior to performing site or installation work, inform all utility companies and have all underground utilities marked.
- Comply with all electrical codes. Electrical equipment and related grounding devices should be installed by a licensed and qualified electrician.
- Only use power sources approved for use in the country of installation to power Campbell Scientific devices.

Elevated Work and Weather

- Exercise extreme caution when performing elevated work.
- Use appropriate equipment and safety practices.
- During installation and maintenance, keep tripod and tripod sites clear of un-trained or non-essential personnel. Take precautions to prevent elevated tools and objects from dropping.
- Do not perform any work in inclement weather, including wind, rain, snow, lightning, etc.

Maintenance

- Periodically (at least yearly) check for wear and damage, including corrosion, stress cracks, frayed cables, loose cable clamps, cable tightness, etc. and take necessary corrective actions.
- Periodically (at least yearly) check electrical ground connections.

Internal Battery

- Be aware of fire, explosion, and severe-burn hazards.
- Misuse or improper installation of the internal lithium battery can cause severe injury.
- Do not recharge, disassemble, heat above 100 °C (212 °F), solder directly to the cell, incinerate, or expose contents to water. Dispose of spent batteries properly.

WHILE EVERY ATTEMPT IS MADE TO EMBODY THE HIGHEST DEGREE OF SAFETY IN ALL CAMPBELL SCIENTIFIC PRODUCTS, THE CUSTOMER ASSUMES ALL RISK FROM ANY INJURY RESULTING FROM IMPROPER INSTALLATION, USE, OR MAINTENANCE OF TRIPODS, tripodS, OR ATTACHMENTS TO TRIPODS AND tripodS SUCH AS SENSORS, CROSSARMS, ENCLOSURES, ANTENNAS, ETC.



Global Sales & Support Network

A worldwide network to help meet your needs



Campbell Scientific Regional Offices

Australia

Location: Garbutt, QLD Australia
Phone: 61.7.4401.7700
Email: info@campbellsci.com.au
Website: www.campbellsci.com.au

Brazil

Location: São Paulo, SP Brazil
Phone: 11.3732.3399
Email: vendas@campbellsci.com.br
Website: www.campbellsci.com.br

Canada

Location: Edmonton, AB Canada
Phone: 780.454.2505
Email: dataloggers@campbellsci.ca
Website: www.campbellsci.ca

China

Location: Beijing, P. R. China
Phone: 86.10.6561.0080
Email: info@campbellsci.com.cn
Website: www.campbellsci.com.cn

Costa Rica

Location: San Pedro, Costa Rica
Phone: 506.2280.1564
Email: info@campbellsci.com
Website: www.campbellsci.com

France

Location: Vincennes, France
Phone: 0033.0.1.56.45.15.20
Email: info@campbellsci.fr
Website: www.campbellsci.fr

Germany

Location: Bremen, Germany
Phone: 49.0.421.460974.0
Email: info@campbellsci.de
Website: www.campbellsci.de

India

Location: New Delhi, DL India
Phone: 91.11.46500481.482
Email: info@campbellsci.in
Website: www.campbellsci.in

South Africa

Location: Stellenbosch, South Africa
Phone: 27.21.8809960
Email: sales@campbellsci.co.za
Website: www.campbellsci.co.za

Spain

Location: Barcelona, Spain
Phone: 34.93.2323938
Email: info@campbellsci.es
Website: www.campbellsci.es

Thailand

Location: Bangkok, Thailand
Phone: 66.2.719.3399
Email: info@campbellsci.asia
Website: www.campbellsci.asia

UK

Location: Shepshed, Loughborough, UK
Phone: 44.0.1509.601141
Email: sales@campbellsci.co.uk
Website: www.campbellsci.co.uk

USA

Location: Logan, UT USA
Phone: 435.227.9120
Email: info@campbellsci.com
Website: www.campbellsci.com