

RADIOTELEMETRY NETWORK APPLICATIONS
MANUAL

REVISION: 2/91

COPYRIGHT (c) 1989, 1991, CAMPBELL SCIENTIFIC, INC.



WARRANTY AND ASSISTANCE

The following warranty applies to the **RF232 Base Station, RF95 Modem, PS12-LA 12 Volt Power Supply with Charging Regulator, PS512M 12 Volt Power Supply with Charging Regulator and Null Modem Ports, CM10 Tripod, and CM6 Tripod.**

These products are warranted against defects in materials and workmanship. This warranty applies for twelve months from date of shipment. We will repair or replace products which prove to be defective during the warranty period provided they are returned prepaid to CAMPBELL SCIENTIFIC, INC. CAMPBELL SCIENTIFIC, INC. will return warranted equipment by surface carrier prepaid. No other warranty is expressed or implied. CAMPBELL SCIENTIFIC, INC. is not liable for consequential damages.

Products may not be returned without prior authorization. To obtain a Returned Materials Authorization (RMA), contact CAMPBELL SCIENTIFIC, INC., phone (801) 753-2342. After an application engineer determines the nature of the problem, an RMA number will be issued. Please write this number clearly on the outside of the shipping container. Campbell Scientific's shipping address is:

Campbell Scientific, Inc.
RMA # _____
815 West 1800 North
Logan, Utah 84321

CAMPBELL SCIENTIFIC, INC. does not accept collect calls.

Non-warranty products returned for repair should be accompanied by a purchase order to cover the repair.



CAMPBELL SCIENTIFIC, INC.™

P.O. Box 551
Logan, UT 84321
USA
Phone (801) 753-2342
TLX 453058
FAX 801-752-3268

Campbell Scientific Canada Corp.
9525 41st Avenue
Edmonton, Alberta T6E 5X7
CANADA
Phone (403) 461-5158
TLX 037-2966 (EDM)
FAX 403-450-2531

Campbell Scientific Ltd.
14-20 Field Street
Shepshed, Leics. LE12 9AL
ENGLAND
Phone (44) 509 601141
FAX (44) 509 601091



RADIOTELEMETRY NETWORK APPLICATIONS

TABLE OF CONTENTS

	PAGE
<i>Warranty</i>	
<i>Preface</i>	
1. INTRODUCTION.....	1-1
2. THE GENERAL RADIOTELEMETRY NETWORK	
2.1 Field Station.....	2-1
2.1.1 The CR10 Field Station.....	2-1
2.1.2 The 21X Field Station.....	2-3
2.1.3 The CR7 Field Station.....	2-3
2.2 Base Station.....	2-6
2.3 Repeater.....	2-6
3. ASSEMBLING THE RADIOTELEMETRY NETWORK	
3.1 Final Layout.....	3-1
3.2 Install Base Station.....	3-1
3.2.1 Base Station Hardware.....	3-1
3.2.2 PC208 Datalogger Support Software.....	3-2
3.3 Install Nearest Repeater/Field Station.....	3-3
3.4 Test the Radiotelemetry Link.....	3-3
3.4.1 A Successful Test.....	3-3
3.4.2 Troubleshooting an Unsuccessful Test.....	3-4
3.5 Technical Troubleshooting of an RF System.....	3-4
3.5.1 Troubleshooting Communication Aid Term.....	3-4
3.5.2 Troubleshooting the Radio and Antenna Combination.....	3-5
3.5.3 Troubleshooting with Attenuation Pads.....	3-6
4. RADIOTELEMETRY NETWORK COMPONENTS	
4.1 RF95 Modem.....	4-1
4.1.1 Physical Description.....	4-1
4.1.2 RF95 States.....	4-1
4.1.3 Setting Station ID.....	4-2
4.1.4 The Carrier Detect Light.....	4-2
4.1.5 Data Transfer Rate.....	4-3
4.1.6 RF95 Modem Communication Protocol.....	4-3
4.1.7 RF95 Modem and the RF Link.....	4-3
4.1.8 RF95 Pin Descriptions.....	4-6
4.2 Radio.....	4-6
4.2.1 Volume Control.....	4-6
4.2.2 Squelch Control.....	4-6
4.2.3 Frequency Switch.....	4-6
4.2.4 P50 Specifications.....	4-7

RF MANUAL TABLE OF CONTENTS

	PAGE
4.3	Power Supply..... 4-7
4.3.1	Lead Acid Batteries..... 4-7
4.3.2	PS12-LA Lead Acid Power Supply..... 4-7
4.3.3	PS512 M Voltage Regulator with Null Modem Ports..... 4-8
4.4	Antennas and Cables..... 4-8
4.4.1	Antenna Installation..... 4-8
4.4.2	Antenna Cables and Connectors..... 4-10
4.5	Tripod and Enclosures..... 4-11
4.5.1	General..... 4-11
4.5.2	CM10 Specifications..... 4-12
4.5.3	CM6 Specifications..... 4-12
4.5.4	Assembly..... 4-12
4.5.5	Enclosures..... 4-13
4.6	RF232 Base Station..... 4-14
4.6.1	RF232 Introduction..... 4-14
4.6.2	Radio Installation..... 4-14
4.6.3	220, 230, and 240 VAC Conversion..... 4-14
5.	OPERATION OF THE RADIOTELEMETRY NETWORK
5.1	Monitoring and Collecting Data - PC208 RF Notes..... 5-1
5.1.1	Collecting Data - TELCOM..... 5-1
5.1.2	General Communication TERM..... 5-3
5.2	Special Applications..... 5-3
5.2.1	Datalogger Initiated Communications..... 5-3
5.2.2	Dual Frequency Operations..... 5-3
APPENDIX A. SETTING THE STATION ID..... A-1	
APPENDIX B. ALTERNATE BASE STATION CONFIGURATIONS	
B.1	The Portable Base Station..... B-1
B.2	Phone-to-RF Base Station..... B-1
B.3	Phone-to-RF Base Station with Measurement Capability..... B-2
APPENDIX C. POWER CALCULATIONS..... C-1	
APPENDIX D. FUNDAMENTALS OF RADIOTELEMETRY	
D.1	Radio Waves..... D-1
D.2	Antennas..... D-1
D.3	RF95 Modem..... D-2
D.4	Transceiver..... D-2
APPENDIX E. RF95 STATES AND EQUIPMENT COMPATIBILITY	
E.1	RF95 States..... E-1
E.1.1	RF95-ME State..... E-1
E.1.2	RF95-SDC State..... E-1
E.2	RF95/P50 vs. HT90 Compatibility..... E-1
E.3	The "U" Command..... E-2

LIST OF FIGURES

1-1	A Basic Radiotelemetry Network.....	1-1
2-1	A General CR10 Field Station	2-2
2-2	A General 21X Field Station	2-4
2-3	A General CR7 Field Station	2-5
2-4	The Radiotelemetry Base Station	2-6
2-5	A Typical Repeater Station.....	2-8
4-1	The RF95 Modem.....	4-1
4-2	Setting the Station ID	4-2
4-3	P50 Radio Settings.....	4-6
4-4	The PD237 Crossover Plate Antenna Mount.....	4-9
4-5	The PD46 Clamp Mount.....	4-10
4-6	Type-NM (male), BNC, and Type-NF (female) Connectors	4-11
4-7	CM10/CM6 Tripod Assembly Drawing.....	4-11
4-8	CM10/CM6 Tripod with Additional Accessories	4-13
4-9	The RF232 Base Station.....	4-15
4-10	Top View of the RF232 Base Station	4-16
B-1	Portable Base Station.....	B-1
B-2	Phone-to-RF Base Station.....	B-2
B-3	Phone-to-RF Base with Measurement Capability	B-2

LIST OF TABLES

2-1	The Components of a General CR10 RF Field Station.....	2-1
2-2	The Components of a General 21X RF Field Station.....	2-3
2-3	The Components of a General CR7 RF Field Station	2-3
2-4	The Components of a Base Station.....	2-6
2-5	The Components of a Typical Repeater Station	2-7
4-1	A Sample of Station ID Numbers and the Corresponding Switch Settings.....	4-2
4-2	RF95 Command Character Summary.....	4-4
4-3	Summary of the Shutdown Block.....	4-5
4-4	Serial I/O Connector Description.....	4-6
4-5	Transceiver Port Pin Description	4-6
4-6	PS12-LA Battery and AC Transformer Specifications.....	4-8
4-7	Common Antennas and Characteristics	4-11
4-8	RF232 Power Conversions.....	4-15
4-9	Pin Description for RF232's 25 Pin Port	4-16
GLOSSARY		G-1
INDEX		I-1

PREFACE

This manual is meant to be an aid in understanding and assembling a Campbell Scientific, Inc. radiotelemetry network. Actual programming of the datalogger and interfacing specific sensors are included in the datalogger manual and sensor manuals.

This Manual is designed to be a handy field guide with installation and setup information on the RF equipment, tripods, and power supplies.

Reading the first three sections of this manual will aid in understanding the purpose and requirements of a Campbell Scientific radiotelemetry network. Radiotelemetry is frequently abbreviated as RF (radio frequency) in this manual.

Figures throughout this manual show Campbell Scientific radiotelemetry equipment being used with weather stations. Although this is a common application, radiotelemetry has many other useful applications.

SECTION 1. INTRODUCTION

Data retrieval from a remote site can be difficult. To accomplish data collection from isolated sites Campbell Scientific, Inc. utilizes a radiotelemetry network. Dataloggers can be accessed by radiotelemetry which requires no physical connection from the computer to the datalogger. It is also not necessary to make regular visits to the remote site for data collection.

The radiotelemetry network is designed for complete computer control. One computer can establish communication with up to 254 remote sites. The PC208 Datalogger Support Software allows data collection from the datalogger, transmitting datalogger programs, and displaying current readings from the datalogger.

The requirements specific to a radiotelemetry network include:

- the distance between radio stations should not be greater than approximately 25 miles, and
- the stations should not have major obstacles between them, therefore they should be within line-of-sight of each other.

The stations communicate over a radio frequency which is specified in Megahertz (MHz). A data communication network must have its own specific frequency so interference from other sources doesn't interrupt communication. Typical radio frequencies are either VHF (Very High Frequency) ranging from approximately 130 to 174 MHz, or UHF (Ultra High Frequency) ranging from approximately 406 to 512 MHz.

A typical RF system is shown in Figure 1-1.

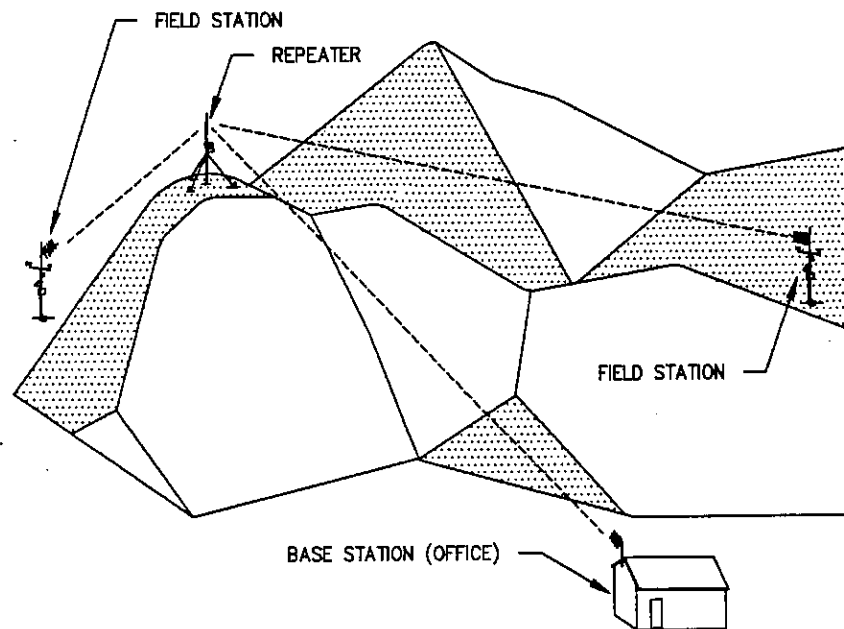
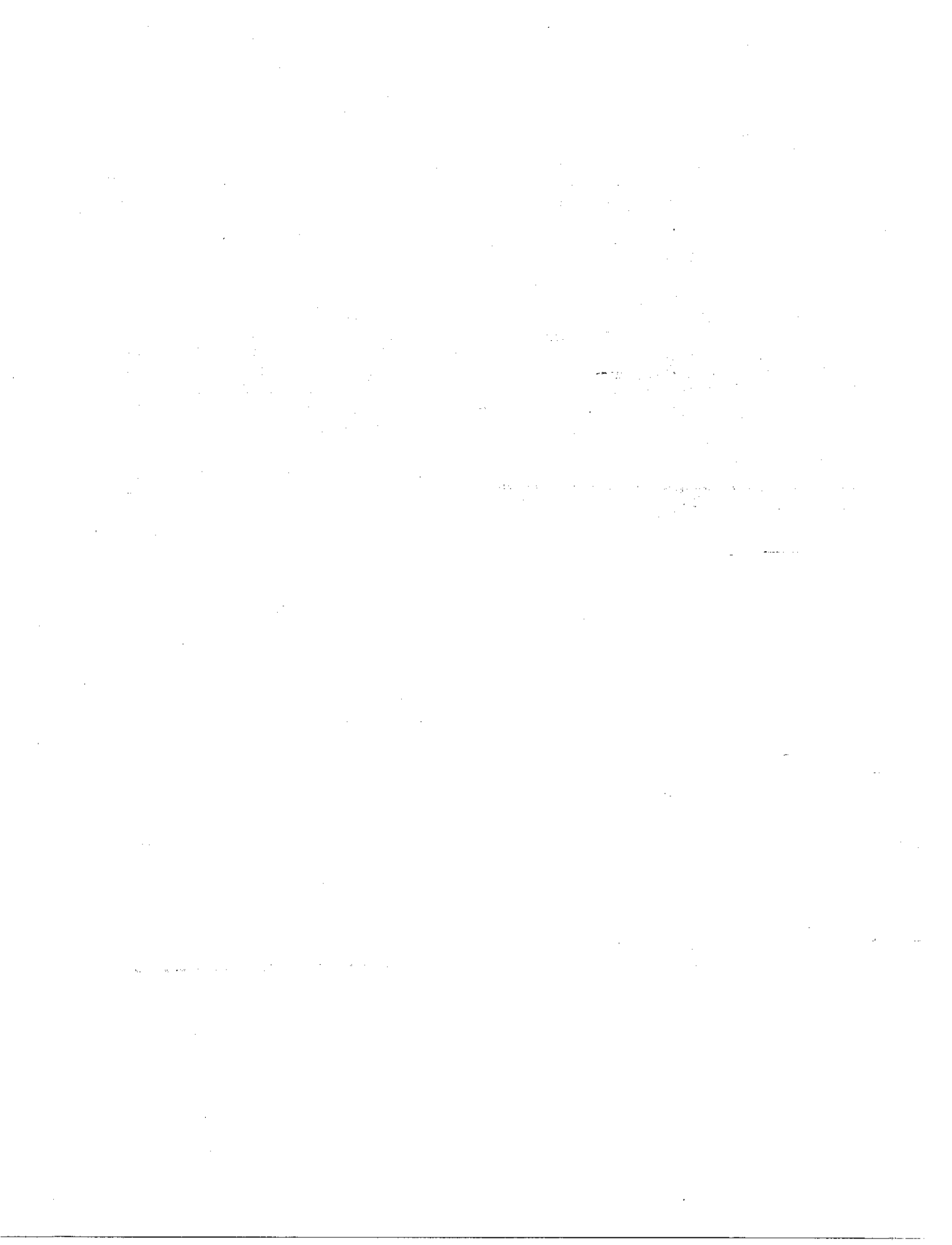

FIGURE 1-1. A Basic Radiotelemetry Network



SECTION 2. THE GENERAL RADIOTELEMETRY NETWORK

The three basic components of a radiotelemetry network are the base station, repeater station, and field station. The data acquisition station (e.g. weather station) where measurements are being made is the field station. A base station, which includes a computer, is used to collect data from the field station. A repeater station acts as a relay between two communicating stations when the distance between the two stations is too great, or when an obstacle impedes direct communication.

Without a repeater, the base station and a field station must be within line of sight, and within approximately 25 miles for communication. With a repeater station, or stations, the base station and a field station can be up to 300 miles apart as long as the repeaters are lined out at approximately 25 mile intervals.

2.1 FIELD STATION

The major components of an RF field station are the datalogger, an RF modem, RF radio, and an antenna. The Campbell Scientific, Inc. datalogger resides at this station taking the desired measurements. An RF radio and antenna are required to transmit and receive information to/from the desired repeater or base station. The RF modem serves as the communication interface between the datalogger and the radio.

Any field station can also operate as a repeater. The only requirement is that the station's antenna must be able to communicate in all desired directions. This may require an omni-directional antenna.

2.1.1 THE CR10 FIELD STATION

A general CR10 field station is shown in Figure 2-1. Components for the typical field station are

listed in Table 2-1. Alternate configurations are possible.

TABLE 2-1. The Components of a General CR10 RF Field Station

Component	Description
CR10	Measurement and Control Module
ENC 12/14	Enclosure
PS12 LA	12V Lead Acid Power Supply w/ Charging Regulator
MSX10	Solar Panel
P50	Radio
RF95	RF Modem
CM10	10 ft. Tripod
COAX	RG-8A/U Cable (Radio to Antenna)
---	Antenna
XXXX	Sensors not listed

SECTION 2. THE GENERAL RADIOTELEMETRY NETWORK

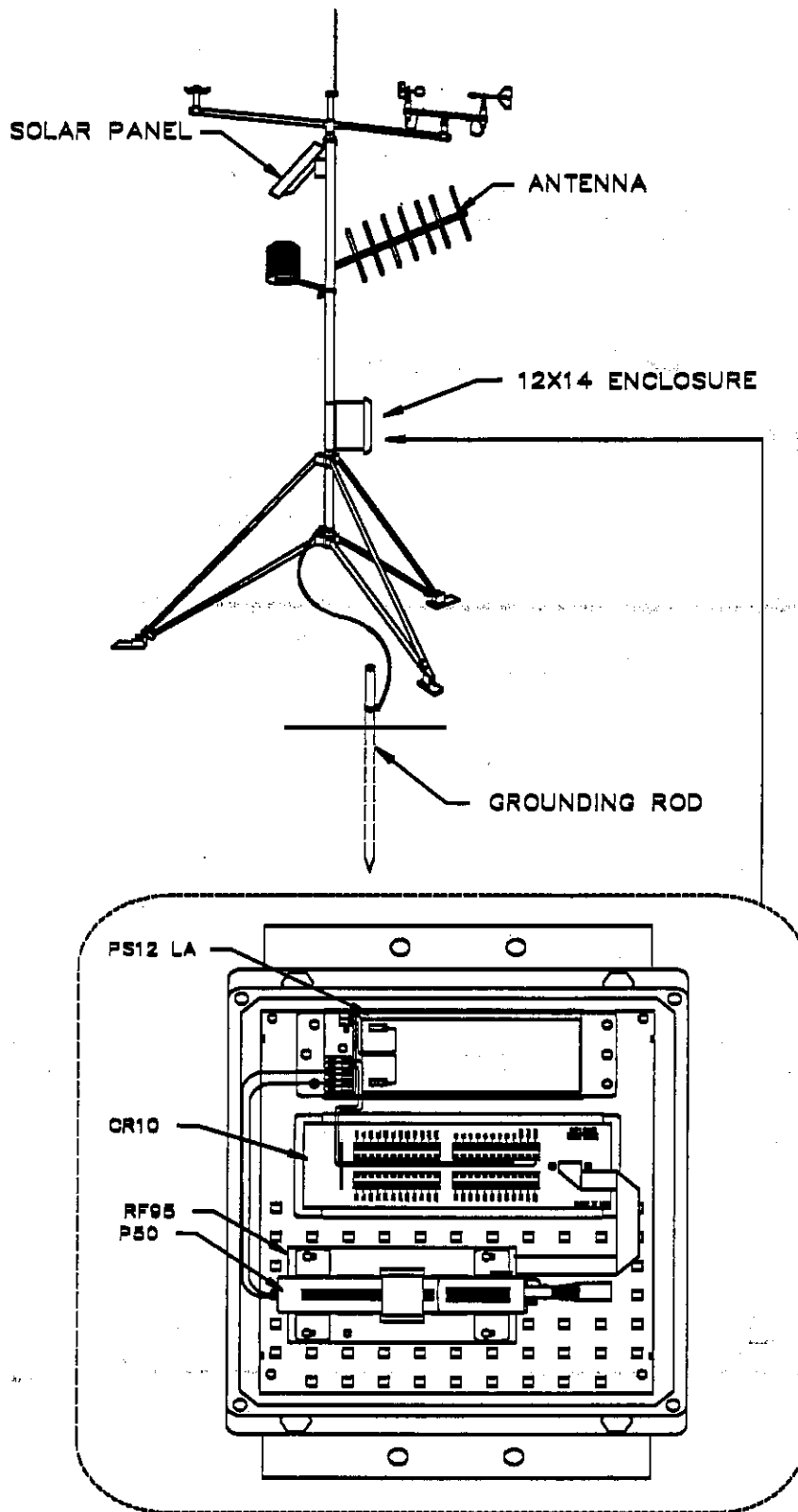

FIGURE 2-1. A General CR10 Field Station

SECTION 2. THE GENERAL RADIOTELEMETRY NETWORK

2.1.2 THE 21X FIELD STATION

A general 21X RF field station is shown in Figure 2-2. Components for the typical field station are listed in Table 2-2. Alternate configurations are possible.

TABLE 2-2. The Components of a General 21X RF Field Station

Component	Description
21X	Micrologger
RF95	RF Modem
P50	Radio
ENC 12/14	Enclosure
PS12 LA	12V Lead Acid Power Supply w/ Charging Regulator
MSX10	Solar Panel
CM10	10 ft. Tripod
COAX	RG-8A/U Cable (Radio to Antenna)
---	Antenna
XXXX	Sensors not listed

TABLE 2-3. The Components of a General CR7 RF Field Station

Component	Description
CR7	Micrologger
RF95	RF Modem
P50	Radio
ENC-24	NEMA 4 Steel Enclosure
M700	Back Mount Bracket for 700 Control Mod.
M720	Back Mount Bracket for I/O Module
---	Extra Elbow for Enclosure
PS12 LA	12V Lead Acid Power Supply w/ Charging Regulator
MSX10	Solar Panel
CM10	10 ft. Tripod
COAX	RG-8A/U Cable (Radio to Antenna)
---	Antenna
XXXX	Sensors not listed

2.1.3 THE CR7 FIELD STATION

A general CR7 RF field station is shown in Figure 2-3. Components for the typical field station are listed in Table 2-3. Alternate configurations are possible.

SECTION 2. THE GENERAL RADIOTELEMETRY NETWORK

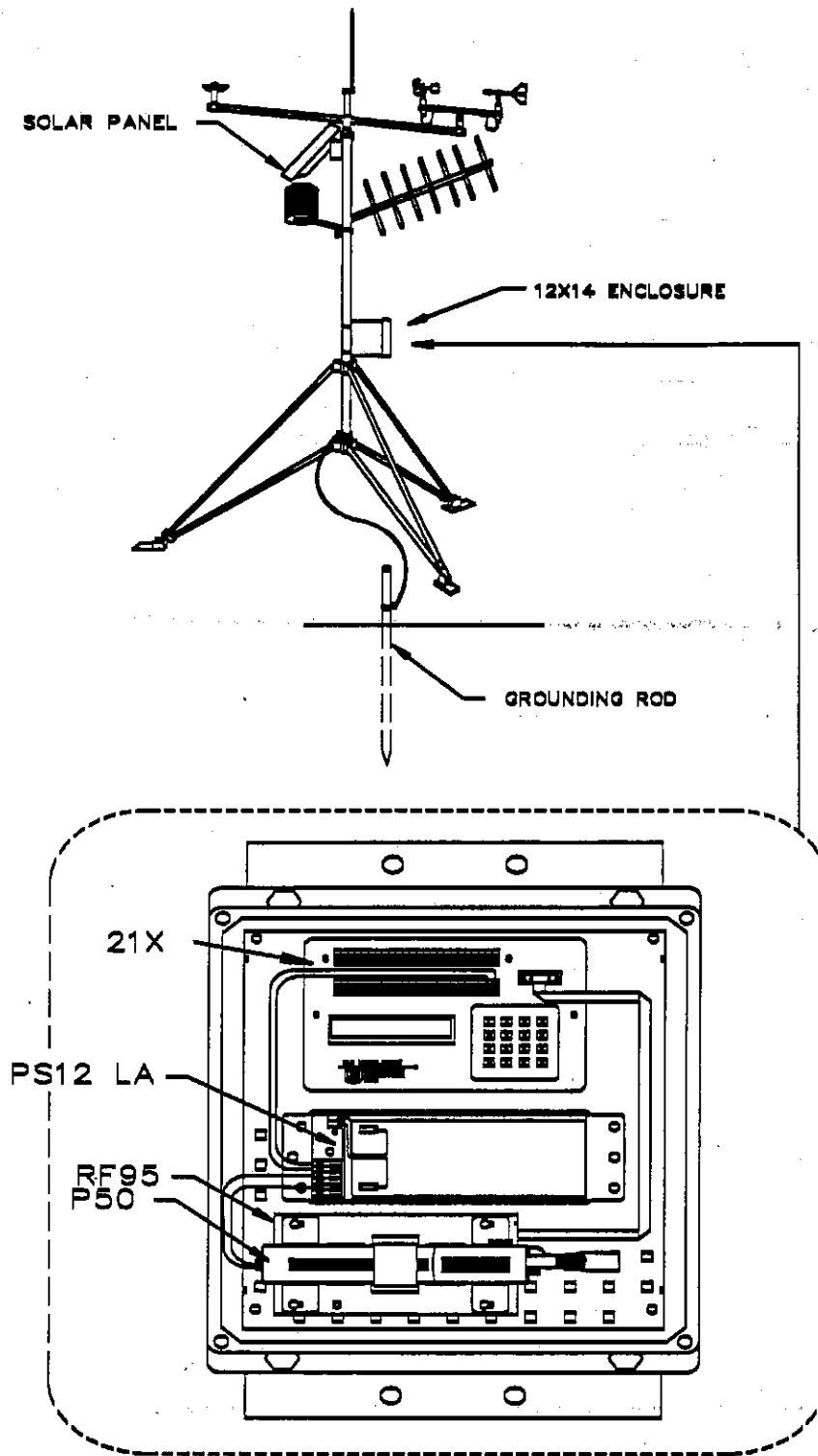

FIGURE 2-2. A General 21X Field Station

SECTION 2. THE GENERAL RADIOTELEMETRY NETWORK

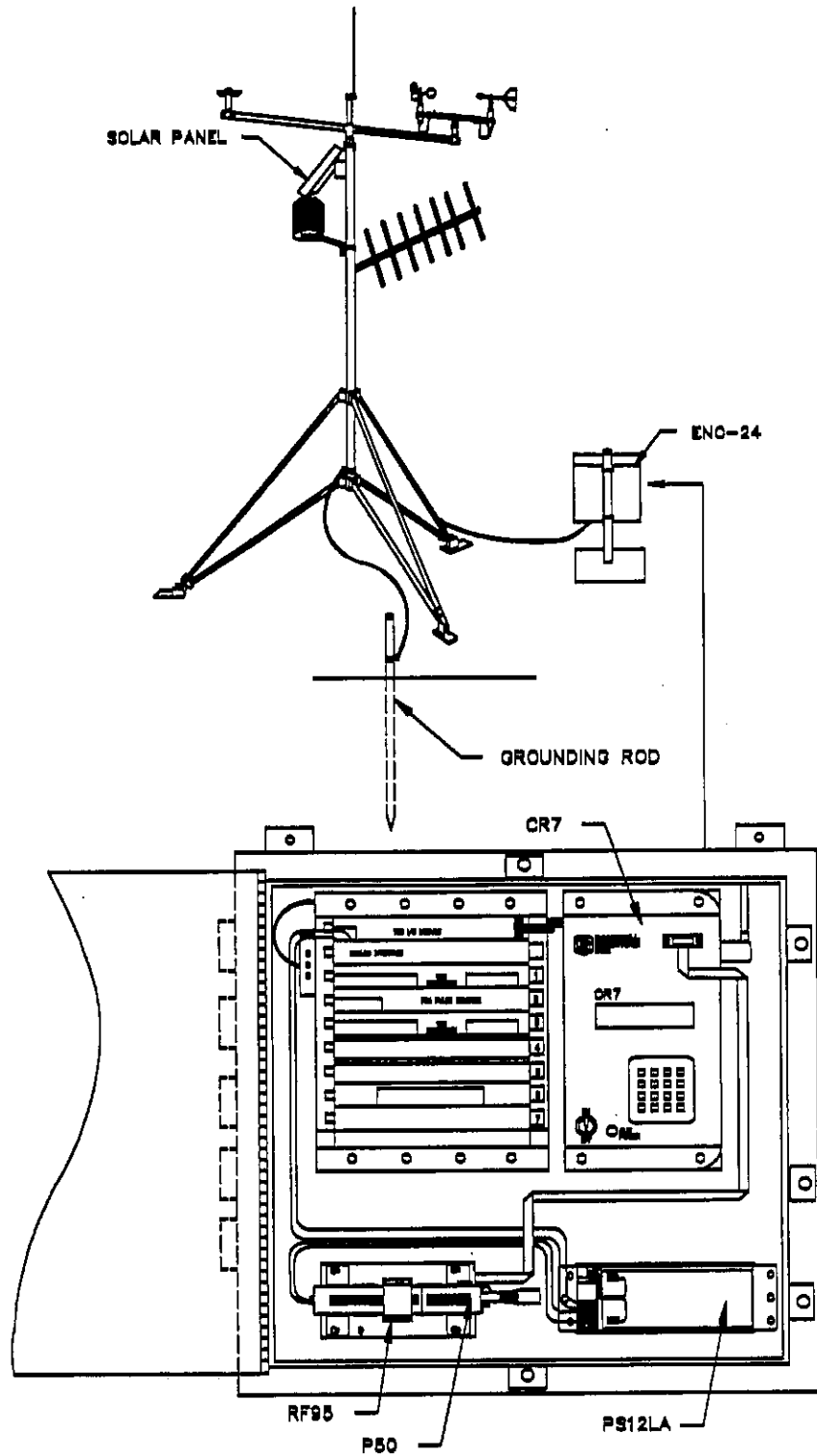

FIGURE 2-3. A General CR7 Field Station

SECTION 2. THE GENERAL RADIOTELEMETRY NETWORK

2.2 BASE STATION

The primary purpose of the base station is to access information collected by individual dataloggers at one common point. Normally, all communication to the field stations originate at the base station. Data retrieval, remote programming, and system analysis can all be done from the base station. The major components of a base station are an IBM or IBM compatible computer, PC208 Datalogger Support Software, RF232 Base Station, an RF radio, and an antenna.

The base station will remain identical regardless of which datalogger is at the field sites. The base station configuration is shown in Figure 2-4.

Components for the base station are listed in Table 2-4.

TABLE 2-4. The Components of a Base Station

Component	Description
RF232	Base Station Radio
P50	Datalogger Support Software
PC208	RG-8A/U Cable (Radio to Antenna)
COAX	Antenna
---	IBM/IBM Compatible computer

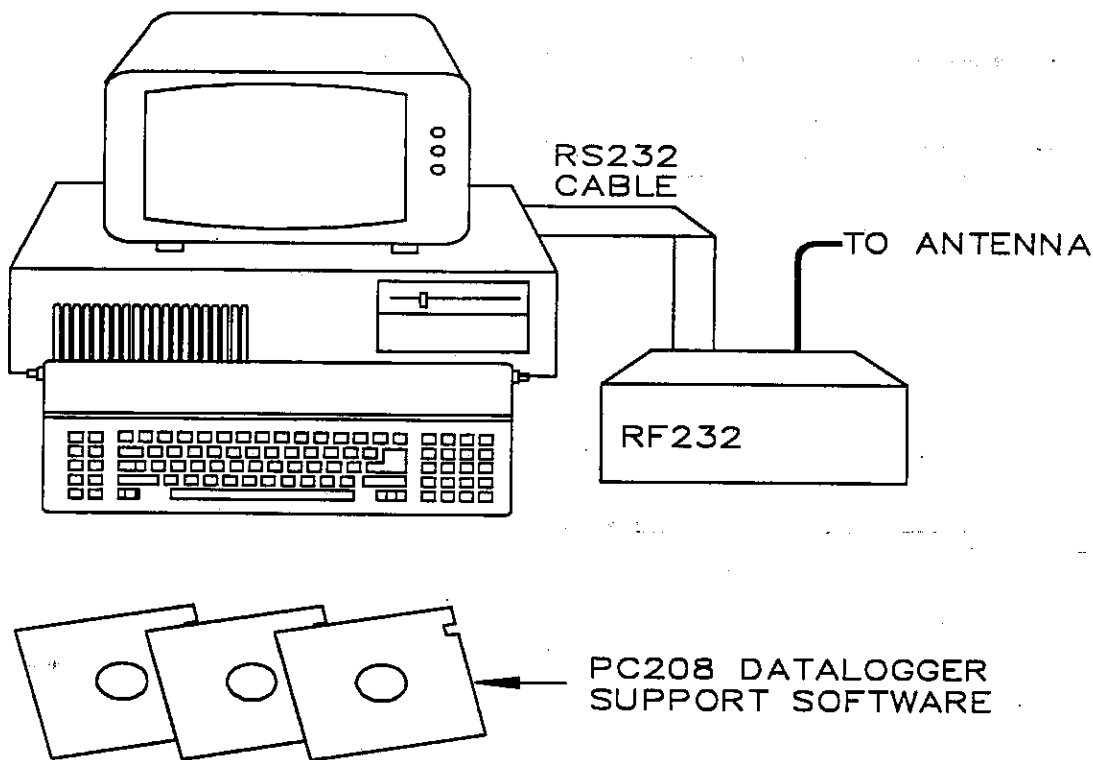

FIGURE 2-4. The Radiotelemetry Base Station

2.3 REPEATER

A repeater is an intermediate station between a base station and a field station(s), or between field stations. A repeater is not always needed in a radiotelemetry network. The two main reasons for having a repeater station are 1) if the distance between two communicating RF stations is greater than approximately 25 miles,

or 2) there is not a line-of-sight path between two communicating RF stations.

A field station can also act as a repeater. It is not necessary to always have a repeater only station.

Figure 2-5 shows a typical repeater station, and Table 2-5 lists the components of this repeater.

SECTION 2. THE GENERAL RADIOTELEMETRY NETWORK

TABLE 2-5. The Components of a Typical Repeater Station

Component	Description
RF95	RF Modem
P50	Radio
ENC 12/14	Enclosure
PS512M	12V Lead Acid Power Supply w/ Charging Regulator and Null Modem Ports
MSX10	Solar Panel
CM10	10 ft. Tripod
COAX	RG-8A/U Cable (Radio to Antenna)
---	Antenna

SECTION 2. THE GENERAL RADIOTELEMETRY NETWORK

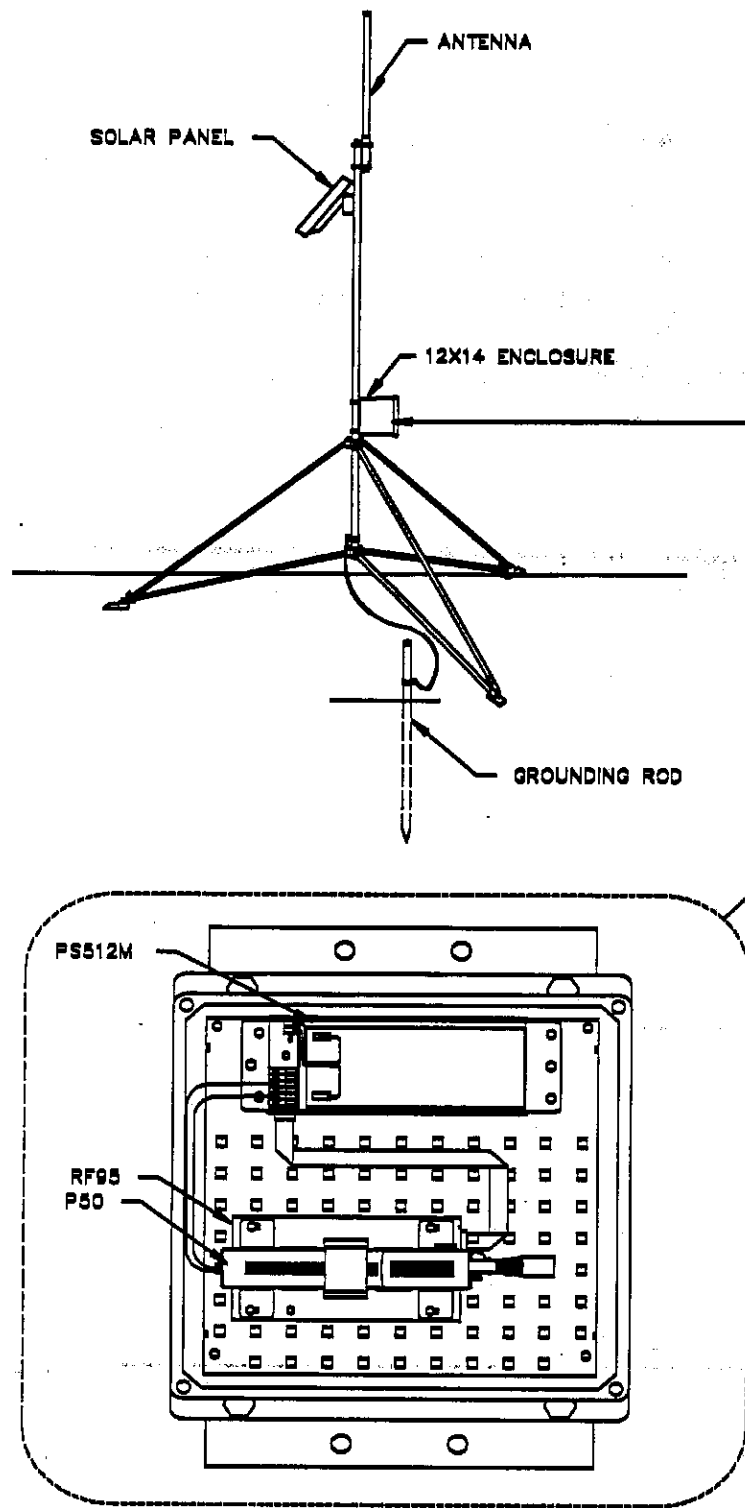

FIGURE 2-5. A Typical Repeater Station

SECTION 3. ASSEMBLING THE RADIOTELEMETRY NETWORK

This section provides a logical order for RF network assembly and deployment. Details of specific components in the system are described in Section 4.0 "Radiotelemetry Network Components." This component section will be cross referenced throughout this assembly section.

3.1 FINAL LAYOUT

The initial locations of the base, field, and repeater stations have likely been determined already. On an area map, preferably a topographic map, locate the RF stations. Draw a line along every communication path. Each field station must have a path connecting it back to the base station. None of the paths can be going through a mountain or large obstacle, this would negate the line-of-sight requirement. A station may need to be moved if this requirement is not met, or a repeater station may be added.

At each station there is an RF modem. Each of the modems requires an ID number (Station ID), the number may range from 0 to 255. On the map, label the base station as 1. Label the remaining stations with different ID numbers. Later, each modem will be set with the corresponding ID number. The Station ID allows the base station to call many different field stations, similar to a phone number.

3.2 INSTALL BASE STATION

3.2.1 BASE STATION HARDWARE

The major component of the base station is the RF232 Base Station. Remove the top of the RF232 by unscrewing the four screws located on the sides. Identify the RF modem directly behind the RF232 cover, the empty space on the left side for the radio, and the 12 V and Ground screw terminals on the small printed circuit board in the back. Refer to Section 4.6 "RF232 Base Station" for locational drawings and a description of the RF232 Base Station.

The RF modem in the RF232 has an ID already set to 1; usually there should be no reason to change this ID. Place the base station radio in the RF232. Set the squelch control fully clockwise and the volume control turned clockwise to approximately 9:00, assuming the off position is at 4:00. Set the frequency switch to 1. Attach the radio's 10 pin multi-colored

connector to the RF modem near the front panel. Connect the red and black power leads from the radio to the 12 V and Ground screw terminals, respectively.

WARNING: Radio transmission without an antenna connected can cause damage to the radio!

Mount the base station antenna in a location which is higher than surrounding buildings or obstacles. A unidirectional antenna must be pointed in the direction of communication, an omni-directional antenna communicates in all directions. The elements of an antenna can be mounted either vertically or horizontally, specifying either vertical or horizontal polarization. Normally, vertical polarization is most beneficial. Regardless of the orientation - make sure that all antennas are polarized identically. Since mounting requirements of various antennas differ, the procedures cannot be explained here. For further information on antennas and cables refer to Section 4.4 "Antennas and Cables."

The coax cable between the antenna and the radio can be connected once the antenna is mounted. The cable should be placed through the hole in the back of the RF232 and connected to the BNC connector on the radio. The cover of the RF232 can now be replaced.

Any antenna must be grounded for lightning protection, especially if the coax cable from the antenna goes inside a building. Connect a large gauge (approximately 8 AWG) copper wire from the antenna to a good earth ground.

Connect a 25 pin RS232 cord from the computer serial port to the RF232. Verify that the RF232 Power Switch is off, and plug in the RF232.

SECTION 3. ASSEMBLING THE RADIOTELEMETRY NETWORK

3.2.2 PC208 DATALOGGER SUPPORT SOFTWARE

Place disk 1 of the PC208 Software in the computer disk drive. Type "INSTALL" preceded by the disk drive and follow the installation instructions. Refer to the PC208 Manual if you have questions about the installation procedures.

There are five main programs in PC208 which are: 1) TELCOM, 2) TERM, 3) SPLIT, 4) EDLOG, and 5) SMCOM. TELCOM is used to collect data from your field stations, and TERM is used to look at current datalogger readings, store datalogger programs, and for troubleshooting. SPLIT is a general purpose data reduction program, and EDLOG is a program editor to aid in writing datalogger programs. SMCOM is for communicating with Campbell Scientific's Storage Modules. Details of these programs are described in the PC208 Manual.

Use TELCOM to establish the communication paths. TELCOM is an abbreviation of telecommunications. Ultimately, a TELCOM Station File is created for each field station. A Station File describes the communication path and conditions for calling a particular field station. Procedures for creating an RF Test Station File are explained in this section. Suggested reading is the Introduction to TELCOM in the PC208 Manual.

After PC208 is installed, type "TELCOM". Enter the file name "RFTEST/E" when asked for a station or script file name. The "/E" is used to edit the Station File named "RFTEST." A menu of parameters will then appear on the screen listing datalogger type, collection method, frequency of data collection, etc. The default values will be automatically listed after the parameter description. With the cursor on a default value, pressing the space bar will toggle different options for that particular value.

Move the cursor to the default value after the parameter 'Datalogger or Command Type.' The default value will be CR10, toggle the space bar until the proper datalogger type is shown for your field station. Continue changing the default values of the listed parameters to match those shown in Example 3-1. Some of the parameters require a number entry (e.g. the parameter 'Primary call interval' simply needs a number of minutes that is desired between calls). For these parameters, just type over the default value which is shown.

After completing Station File RFTEST, your display should be similar to Example 3-1. Exceptions would include the datalogger type, date and time after 'Next time to call.' Also, COM1 under 'Interface Devices' may be COM2, 3, or 4, depending on the address of the intended serial port.

EXAMPLE 3-1. TELCOM Station File - RFTEST

```
Station File Name:  RFTEST

Datalogger or Command Type:  CR10
Data Collection Method:  Since Last Call;Append File;1st Area
Nbr of Arrays to Backup on First Call:  1
Data File Format:  Comma Delineated ASCII
Fix Datalogger Clock Using PC Clock:  No
Primary Call Interval (minutes):  1
Recovery Call Interval #1 (minutes):  1
Repetitions of Recovery Interval #1:  1
Recovery Call Interval #2 (minutes):  1
Maximum Time Call Will Take (minutes):  3
Next Time To Call:  4/10/89 0:13:10

Interface Devices:
COM1      Baud Rate:  9600
RF Modem  RF Path:    10F
End
```

The RF Path at the bottom of the Station File designates which field station to call. In the example shown, the base station will call the field station with a Station ID of 10. If a repeater is needed to contact field station 10, the repeater ID must also be specified. For example, "RF Path: 5 10F", would call field station 10 through a repeater with a Station ID of 5. The "F" at the end of the RF Path will be explained later. The base station is now ready to communicate with a field station.

3.3 INSTALL NEAREST REPEATER/FIELD STATION

It is now time to install the nearest field station. If it communicates with the base station via a repeater, the repeater station must also be installed.

Following is the order in which a general RF field station should be installed. A repeater station is installed in the same order. For instructions on installing any particular component, refer to either Section 4 "Radiotelemetry Network Components," the drawings in Section 2 "The General Radiotelemetry Network," or the sensor manuals.

1. Tripod
2. Enclosure and datalogger - Turn on datalogger.
3. Antenna - Orientate correctly, remember direction and polarization.
4. Solar Panel
5. Power Supply
6. Sensors
7. Radio - Set squelch, volume, and frequency switch.
8. RF Modem - Set the Station ID according to the map.

3.4 TEST THE RADIOTELEMETRY LINK

With the field station installed, return to the base station for initial testing of the communication link. An RF link can also be tested at the field site with a portable base station; hardware

requirements for the portable base station are described in Appendix B.

The Station File RFTEST must first contain the proper RF path. Edit the Station File RFTEST by typing "TELCOM RFTEST/E", typing "/" after "RFTEST" puts you directly in the Station File for editing. Repeatedly hit return until the cursor reaches the RF path. Enter the proper RF path to communicate with the desired station. For help refer to Example 3-1, Section 5 "Monitoring and Collecting Data PC208 RF Notes," or the PC208 Manual.

After entering the 'RF Path', press "CTRL P" to save the Station File. TELCOM will automatically call the field station after it is saved. If everything is setup properly, the base station will call the field station, receive a datalogger status line on the computer, collect any data that is in the datalogger, and receive RLQA quality accumulators. The RLQA numbers are explained in Section 4.1 "RF95 Modem."

3.4.1 A SUCCESSFUL TEST

Two files are created by calling the station if the RF link was setup properly. One file is RFTEST.CQR which includes the RLQA numbers (RF Link Quality Accumulators), and the other is a data file named RFTEST.DAT. RFTEST.CQR will consist of one line of numbers for each time the station was called. The first two numbers are the Julian date and time of call, followed by three numbers for each modem in the link. If there is no repeater in the link, there will be eight numbers: one for date, one for time, three for the field station RF modem, and three for the base station modem. The first number from each modem should be small (close to 0), the second and third numbers should be 102 (± 70).

RFTEST.DAT will contain the data, if any, that was collected from the datalogger.

To call the same field station again, simply type TELCOM RFTEST/C.

After the successful test, setup the next nearest field station and test that radiotelemetry link.

SECTION 3. ASSEMBLING THE RADIOTELEMETRY NETWORK

3.4.2 TROUBLESHOOTING AN UNSUCCESSFUL TEST

An error file is created as a result of communication problems. Each time a communication error occurs, the message is stored in a file with the .ERR filetype. The filename is the name of the Station File, in this case RFTEST.ERR. Listed in the error file will be the date and time the error occurred along with the error message. As errors occur they are appended to the existing error file.

A possible error message is "Communication not established with RF Modem." In this case check the following items:

1. RF232 Base Station plugged in?
2. RF232 Power Switch turned on?
3. Does the TELCOM Station File match Example 1?
4. Is the proper COM port specified in the Station File?
5. Is the SC12 9-pin ribbon cable inside the RF232 connected from the small circuit board to the RF95?

Another possible message is "RF Modem Set Link Failed" which will be seen after the software attempts to establish communication three times. In this case check the following items:

1. Check radio power supply, with the radio transmit button depressed, and connections.
2. Are the radios plugged into the RF modems?
3. Are the Station IDs set properly?
4. Is the 'RF Path' in the Station File correct?
5. Are the antennas oriented correctly?
6. Check all antenna cable connections.
7. Turn radio off. Unplug the SC12 9-pin ribbon cable from the RF95 in the RF232, reconnect the SC12 cable and watch the carrier detect light. Does the light stay on for one second, off for one second, on for one second, and

then off? If not, the RF95 could have bad RAM or ROM. Also check the field/repeater station modems.

8. Is the frequency switch on the radios set to 1?
9. Is the field station datalogger turned on and powered?

The error message "RF Modem Does Not Respond" can occur if communication is not returned to the base station. Check the following items:

1. Are all radios in the link turned on and powered?
2. Are all RF95 Modems connected?
3. Are the antennas oriented properly?
4. Is the SDC switch open?
5. Is the proper communication port being specified?

If problems still exist, read Section 3.5 "Technical Troubleshooting of an RF System," and then call Campbell Scientific's Marketing Department for support.

3.5 TECHNICAL TROUBLESHOOTING OF AN RF SYSTEM

Complete troubleshooting of an RF system requires a voltmeter, a directional wattmeter (e.g. a Bird Electronic Corporation Wattmeter), and possibly some attenuation pads.

Troubleshooting begins with the simplest RF link in the system, which is usually communication with the nearest field station. There is **NO** substitute for first checking the hardware connections, Station IDs, and everything listed in the previous section.

3.5.1 TROUBLESHOOTING COMMUNICATION AID TERM

TERM is the general purpose communication package. Unlike TELCOM, TERM does not always automatically setup or shut down an RF link. The advantage of TERM is that it is possible

SECTION 3. ASSEMBLING THE RADIOTELEMETRY NETWORK

to try and retry the individual steps successively by using the terminal emulator option.

TERM uses portions of the Station File already setup in TELCOM. To edit the TERM Station File type "TERM name/E" where "name" is the Station File name, in this case it is RFTEST. Be sure the correct COM port and RF path are entered. After corrections are made, save the Station File and a list of options will appear. Option T (Terminal Emulator) is the option that is most beneficial in troubleshooting.

A general understanding of the communication sequences is necessary to properly troubleshoot an RF link. The base station RF modem (RF95) is called the Start Of Link modem, or SOL modem. The field station RF modem is called the End Of Link modem, or EOL modem. When powered up, the SOL modem immediately goes into a Wait Mode. The RF95 Modem has five different modes of operation; these are described in the RF Manual Applications Manual.

After option T is chosen, and [ENTER] is pressed a couple of times, the baud rate of the base station RF modem will be set. This baud rate can be set at 300, 1200, or 9600 baud. If the communication baud rate is set properly, the modem will respond by sending an exclamation point (!) prompt. If the exclamation point is not returned, the communication port (COM port) could be configured improperly, the wrong COM port may be specified in the Station File, the base station may not be powered, or the radio and RF modem may not be connected properly.

After receiving the exclamation point, the SOL modem is in the Local Command Mode. The RF95 will respond to the following commands in the Local Command Mode: 1) S - the Link Setup Command, 2) F - the Fast Command, 3) R - the Read Command, 4) T - the Terminate Command, and 5) U - the Old Link Command.

The RF link must first be setup after the RF95 is in the Local Command Mode. Enter the 'RF Path' for communication with that field station. For example, "S5 8F" communicates to a field station with a Station ID of 8 through a repeater with an ID of 5.

After the RF path, or setup string of ID numbers, is entered, pressing [ENTER] will cause a setup block to be transmitted down the RF link. If the setup is successful, and a link is established, a dollar sign (\$) will be sent to the computer. Slowly pressing [ENTER] a few times should produce an asterisk (*) from the datalogger, which means the baud rate has been set. The datalogger at the field station will be in standard Telecommunications Mode. At this point the SOL modem and EOL modem will be in the Transparent Mode of operation. Press A, wait, and then press [ENTER] to receive a datalogger status sequence from the datalogger. If everything is successful, press "CTRL -", then "Q" to quit.

If no dollar sign (\$) appears from the SOL modem, it is important to listen to the base station radio breaking squelch. This can give an idea of where the RF link is failing. The object is to decipher which radios are breaking squelch on the base station radio. If nothing is heard from the base station radio then there is a problem at the base station. The problem could be the modem, radio, power, or connections.

If the radio breaks squelch only once, then the radio is transmitting, but the next radio in the link is not transmitting. This could be caused by improper antenna orientation, bad connections on the antenna cables, insufficient current supply at the base station, or something wrong at the first station in the link. Besides the base station radio breaking squelch to transmit the setup block, the base station radio should also break squelch when the first station in the link transmits whether it be to another repeater or field station, or directly back to the base station. It is possible that the base station radio will break squelch many times depending on the number of stations in the RF link and their vicinity. Try to decipher which radios are breaking squelch on the base station radio and which are not.

3.5.2 TROUBLESHOOTING THE RADIO AND ANTENNA COMBINATION

To test a station's radio/cable/antenna transmission capabilities, a directional wattmeter is needed such as Bird Electronic Corporation's Model 4304A Wattmeter. Proper connectors are also needed to place the wattmeter in series between the radio and antenna cable. A

SECTION 3. ASSEMBLING THE RADIOTELEMETRY NETWORK

voltmeter is required to measure the battery voltage of the datalogger with and without radio transmission.

Place the wattmeter in series between the radio and antenna cable. Set the wattmeter to the 15 Watt range, or the next highest wattmeter setting, and point the directional arrow first toward the antenna cable to measure forward power (W_f). Depress the transmit button on the radio, let the wattmeter stabilize, and write down the wattmeter reading. Reverse the directional arrow so it is pointing back toward the radio, depress the transmit button, let the wattmeter stabilize, and write down the wattmeter reading. This second reading is the reflected power (W_r). Take the square root of the quantity reflected power divided by the forward power to arrive at the square root ratio (R). Calculate the Voltage Standing Wave Ratio (VSWR) with the following equation:

$$\text{VSWR} = [(1 + R)/(1 - R)],$$

where, $R = (W_r / W_f)^{1/2}$.

The impedance of the RF transmission cable (usually RG-8A/U) and antenna combination should match the impedance (50 ohms) of the radio output circuit. When the transmission cable or antenna does not match the impedance of the output circuit of the radio, not all of the energy supplied to the cable will flow into the antenna. Some of the energy supplied will be reflected back to the radio causing standing waves on the cable. The ratio of voltage across the line at the high voltage points to that at the low voltage points is known as the Voltage Standing Wave Ratio, or VSWR. The VSWR should be kept below 1.5:1 for error free radiotelemetry.

For example, if the forward power (W_f) is 5 Watts and the reflected power (W_r) is 0.2 Watts the VSWR is 1.5:1.

A problem has been found if the VSWR is greater than 1.5:1. The VSWR will increase when:

- the antenna is used in proximity of metal,
- transmitting inside a building,
- the cable is bad,
- the antenna frequency does not match the radio frequency,
- there is a bad connection.

If the VSWR is below 1.5:1, then that radio/cable/antenna link is good. However, be sure the antenna is orientated properly.

While at the station also check the voltage on the 12 V port both with and without the transmit button depressed. Regardless of the battery type, the datalogger requires a minimum of 9.6 Volts.

3.5.3 TROUBLESHOOTING WITH ATTENUATION PADS

If stations can be heard breaking squelch on the base station radio, but communication quality is poor or not being setup properly, there may be a marginal or low signal power inherent in the RF link. In this case, it is a good idea to do a signal power check with attenuation pads for each sub link in a complete RF link. Every RF link has one or more sub links. For example, if there is one repeater in an RF link then there is a sub link between the base station and the repeater and a sub link between the repeater and the field station. The sub links should be checked in both directions of communication.

Before proceeding, it is a good idea to calculate the theoretical signal power for each of the RF links. Appendix C of the RF Telemetry manual outlines the calculations.

Signal power must be greater than -95 dBm at the standard 3.0K baud transmission rate, or -80 dBm @ 2.4K baud. However, squelch will break on the radios with a power greater than -115 dBm. Therefore, there is a 20 dBm range in which the radios are not working, but may "sound" proper.

An attenuation pad inserted into the link increases the power loss of the system. If a 20 dBm attenuation pad, or two 10 dBm pads in series, is inserted in the link and subsequently the radio will not break squelch, the signal power is between -95 and -115 dBm which is below the power limit for good data transmission.

Similarly, if a 10 dBm attenuation pad is inserted in the link and the radio subsequently will not break squelch, the actual signal power is between -105 and -115 dBm. In this case, the signal power is far below the power limit.

SECTION 3. ASSEMBLING THE RADIOTELEMETRY NETWORK

First test the sub link of the base station to the first repeater or field station. Initially treat the base station as the transmitting station and the first field or repeater station as the receiving station. Disconnect the radio's multicolored cable from the RF modem. With somebody at each station, depress the base station transceiver button and listen at the receiving station to hear if squelch is broken. If squelch is not broken then either the signal power is less than -115 dBm, or something is wrong with the power supply, antenna orientation, or cable connections. If squelch is broken on the receiving radio, the site can be tested with attenuation pads to determine the approximate signal power if it is between -115 and -95 dBm.

Insert the attenuation pad(s) (20 dBm) between the radio and antenna of the **receiving station ONLY** (most attenuation pads have a limited current capacity). Depress the base station transceiver button. If squelch is broken at the receiving station, this sub link is good in this direction. If squelch is not broken, this sub link

has signal power between -95 and -115 dBm which should be corrected. Corrections can involve shortening distances, reorientating antennas, providing a better power supply, or shortening coaxial cable lengths.

If it did not break squelch with the 20 dBm attenuation pad, it is possible to decrease the attenuation to 10 dBm to determine if signal power is between -95 and -105 dBm, or between -105 and -115 dBm. This will identify if the signal power is close or far away from -95 dBm.

If it did break squelch with the 20 dBm attenuation pad, then that sub link is good in that direction. The next sub link can now be tested. Remember to place the attenuation pads at the receiving station only! If all of the sub links were good, the same sublinks can be tested in the opposite direction. If reversing directions in a sub link gives bad results while the other direction is good, be suspicious of the transmitting radio in the bad direction, and the radio's power supply.



SECTION 4. RADIOTELEMETRY NETWORK COMPONENTS

4.1 RF95 MODEM

The RF95 is an interface between the computer and the radio when used at a base station, and an interface between the radio and the datalogger at a field station. In a repeater station, the RF95 is an interface between two other communication stations.

The RF95 replaces Campbell Scientific's old DC95 and SDC RF Modems. The RF95 is compatible with both the DC95 and SDC Modems. Refer to Section 4.1.2 "RF95 States" and Appendix E "RF95 States and Equipment

Compatibility" for compatibility considerations.

4.1.1 PHYSICAL DESCRIPTION

The front panel of the RF95 is shown in Figure 4-1. There are two ports for interfacing external devices. The port labeled TRANSCEIVER connects to the radio, and the port labeled SERIAL I/O connects to the datalogger, or the PS35 in the case of a repeater or phone-to-RF base station. The red light labeled CARRIER DETECT is used primarily to indicate when a carrier frequency has been detected by the radio. This is explained later in further detail.

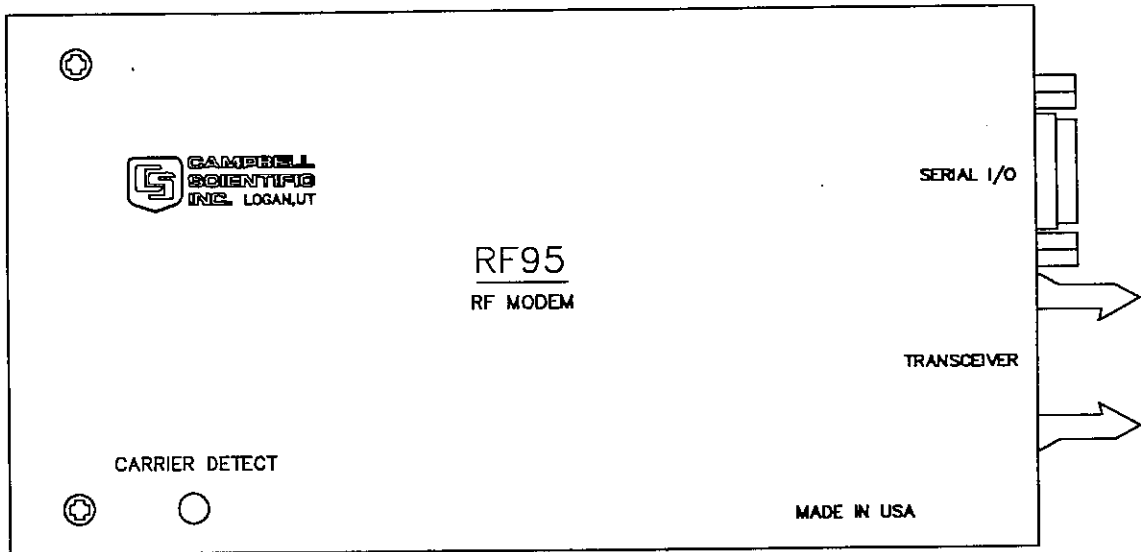

FIGURE 4-1. The RF95 Modem

4.1.2 RF95 STATES

The RF95 Modem operates in one of two separate states. The RF95 can be utilized in either the RF95-ME (Modem Enable) state or the RF95-SDC (Synchronous Device Communication) state. The proper state must be determined before employing the RF95 in the field. A switch inside the RF95 needs to be set accordingly.

The RF95-ME state is always used with 21X and CR7 dataloggers.

The RF95-ME state is normally used with CR10s also.

The CR10 can also use the RF95-SDC state. The CR10 combined with the RF95 in the RF95-SDC state has the advantage that a phone-to-RF base station can have measurement capability. Only the CR10 at a phone-to-RF base station needs to be switched to the RF95-SDC state.

A switch with nine different dip switches is inside the RF95, the RF95 cover must be removed to locate the switch. The ninth switch sets the RF95 State. The RF95-ME state is chosen by setting the ninth dip switch open, represented by 1. The RF95-SDC state is chosen by setting the ninth dip switch closed, represented by 0. Refer to Figure 4-2. The RF95 is shipped with the switch set for the RF95-ME state.

SECTION 4. RADIOTELEMETRY NETWORK COMPONENTS

Further information on the RF95 states and compatibility with older Campbell Scientific equipment can be found in Appendix E "RF95 States and Equipment Compatibility."

4.1.3 SETTING STATION ID

Each RF95 must have a Station ID, which is similar to a phone number. This allows one base station to communicate with any one particular field station.

The Station ID can be any number from 0 to 255, the Station ID is set with the switch inside the RF95. The first eight dip switches are used to set the Station ID. Table 4-1 shows the switch settings for several Station ID numbers, Appendix A shows all possible Station ID numbers. The dip switches can either be open, represented by 1, or

closed, represented by 0; X in Table 4-1 refers to "don't care." The ninth dip switch is set according to the desired RF95 state, see Section 4.1.2 "RF95 States." The RF95 is shipped with a Station ID of 1, and is set in the RF95-ME state.

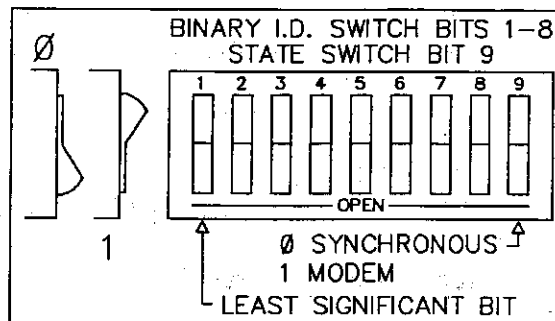

FIGURE 4-2. Setting the Station ID

TABLE 4-1. A Sample of Station ID Numbers and the Corresponding Switch Settings

Station ID	Switch Settings		Station ID	Switch Settings	
	1234	56789		1234	56789
0	0000	0000X	140	0011	0001X
10	0101	0000X	150	0110	1001X
20	0010	1000X	160	0000	0101X
30	0111	1000X	170	0101	0101X
40	0001	0100X	180	0010	1101X
50	0100	1100X	190	0111	1101X
60	0011	1100X	200	0001	0011X
70	0110	0010X	210	0100	1011X
80	0000	1010X	220	0011	1011X
90	0101	1010X	230	0110	0111X
100	0010	0110X	240	0000	1111X
110	0111	0110X	250	0101	1111X
120	0001	1110X	*255	1111	1111X
130	0100	0001X			

* Station ID 255 is reserved for phone-to-RF base stations.

4.1.4 THE CARRIER DETECT LIGHT

The Carrier Detect light on the front panel of the RF95 has several purposes. The primary function of the light is to indicate when data is being received or transmitted. The light will stay on when a network frequency originating from another RF95 is detected. If a signal is detected which isn't intended for that station, the light will shut off after about two tenths of a second.

The Carrier Detect light can also be used to check the RAM (Random Access Memory) and ROM (Read Only Memory) of the RF95. With the radio disconnected and the datalogger in the LOG (*0) Mode, connect the datalogger to the RF95 Serial I/O Port with a 9 pin ribbon cable. The sequence of the light flashing after connection indicates the RAM and ROM status.

Both the RAM and ROM are good if the light comes on for one second, off for one second,

SECTION 4. RADIOTELEMETRY NETWORK COMPONENTS

and then back on for one second. The RAM is faulty if the light is on for one half second and off for one half second, continuously. The ROM is faulty if the light comes on for one second, off for one half second, on for one half second, and then off for one half second, continuously.

4.1.5 DATA TRANSFER RATE

The data transfer rate is the time it takes to get data from the datalogger to the computer. In general, data can be transferred at a rate of about 30 data points/second (60 bytes/second) without a repeater. If a repeater is used, an approximate data transfer rate is 22 data points/second.

4.1.6 RF95 MODEM COMMUNICATION PROTOCOL

Comprehension of this section is not necessary for routine operation of the RF95 Modem. The PC208 Datalogger Support Software accounts for the necessary communication protocol.

There must be a RF95 Modem at both the calling (or computer) end of the transmission link, and at the answer (or datalogger) end of the transmission link. The modem at the calling end is the Start Of Link (SOL) modem, and the modem at the answer end is the End Of Link (EOL) modem.

RF95 Modems must also be used at repeater stations. These RF95 Modems are termed Middle Of Link (MOL) modems.

4.1.6.1 RF95 Modes of Operation

The RF95 Modem has five general modes of operation. These modes are the Wait Mode, Local Command Mode, Repeater Mode, End of Link Mode, and Transparent Mode.

The RF95 is in the **Wait Mode** of operation when it is waiting to enter one of the four other modes of operation. The Wait Mode is entered after 1) the power-up sequence is completed, 2) following the "T" command when in the Local Command Mode, and 3) when the system is reset by the Time-out Timer. The Time-out Timer is a 60 second timer which is set every time a valid transmission block is received on the RF link. The datalogger being in

Telecommunications Mode will override the Time-out Timer.

The **Local Command Mode** is used to setup and shutdown an RF link. The Local Command Mode is entered when the datalogger goes into Telecommunications Mode after being in the Wait Mode. In this mode the RF95 responds to command characters received on the Serial I/O port.

The RF95 is in the **Transparent Mode** after the RF link has been established. In the Transparent Mode, any data received on the Serial I/O port are organized into data blocks for transfer through the RF link.

The **Repeater Mode** is entered by MOL RF95 Modems. The function of the Repeater Mode is to receive and then transmit data blocks. The signature of each data block is checked before being propagated to the next RF station. The block is discarded if the signature of the data block is incorrect. The RF95 enters the Repeater Mode whenever the Carrier Detect line goes low on the Transceiver port followed by a valid setup block which sets the RF95 as the a repeater in a predetermined RF link.

The **End Of Link Mode** is entered when the Carrier Detect line goes low on the Transceiver port followed by a valid setup block which sets the RF95 as the EOL modem. Upon entering the EOL Mode, the RF95 brings the Serial I/O Ring line high which raises the datalogger ME line, thus causing the RF95 to enter the Transparent Mode. The Ring line is reset after the ME line comes high.

4.1.7 RF95 MODEM AND THE RF LINK

The RF link is the communication path which is opened between the Start Of Link modem and the End Of Link modem, along with any Middle Of Link modems. Any RF link must first be established, then maintained, and finally shutdown.

When collecting data, TELCOM establishes, maintains, and shuts down the RF link as discussed below.

4.1.7.1 Establishing the RF Link

The SOL RF95 is first brought into the Local

SECTION 4. RADIOTELEMETRY NETWORK COMPONENTS

Command Mode of operation. In the RF95-ME State, this is done when the ME line is high on the Serial I/O port and the SOL modem is in the Wait Mode of operation. After the ME line is brought high, the baud rate of the SOL modem is set by repetitively pressing [ENTER]. The SOL modem can operate at 300, 1200, or 9600 baud. When the baud rate is set, the SOL modem will respond by sending a carriage return line feed (CR-LF) and an exclamation point (!). In the RF95-SDC State, the Local Command Mode is entered after addressing, some explanation is contained in Appendix E "RF95 States and Equipment Compatibility."

In the Local Command Mode, the SOL modem responds to command characters received from the terminal, or computer. The command characters are summarized in Table 4-2. All command characters must be capital letters!

TABLE 4-2. RF95 Command Character Summary

<u>Command</u>	<u>Description</u>
S	Link Setup Command. The Link Setup Command is followed by a string of setup numbers representing the ID numbers of the modems in the RF link.
F	Fast Command. The "F" Command is placed at the end of the string of setup numbers. In the RF95-ME State, the Serial I/O port of the EOL modem will communicate with the datalogger at 9600 baud with the "F" Command. In the RF95-SDC State, the baud rate from the computer to the SOL modem will be 9600.
R	Read Command. The "R" Command reads back the Shutdown Block.
T	Terminate Command. The "T" Command will reset the SOL modem to the Wait Mode of operation.

U Old Link Command. The "U" Command will force RF communication between radios at 2400 baud rather than 3000 baud. DC95s purchased before February, 1989 can only be used at 2400 baud. For further information see Appendix E.

The first step in setting up an RF link, once in the Local Command Mode, is to create a setup block using the "S" command. The setup string is entered via the computer as follows:

Sxxx yyy

where, xxx = ID number of the RF95 which is acting as the repeater in the link. If no repeater is used then xxx is omitted.

yyy = ID number of the EOL modem.

xxx and yyy are numbers from 0 to 255, inclusive. The user can have up to 12 repeaters in any RF link. Example 4-1 shows the setup block for an RF link which will communicate through three repeaters to an EOL modem, with Station ID numbers of 10, 25, 50, and 30, respectively. The Fast Command is used to speed data transfer.

EXAMPLE 4-1. A Sample Setup Block

S10 25 50 30F

Notice that it is not necessary to include the station ID of the SOL modem.

Press [ENTER] following the setup string of station IDs to transmit the setup block. When the RF link is established, a verification block is sent from the EOL modem to the SOL modem. Upon receiving this verification block the SOL modem and EOL modem have entered the Transparent Mode of operation. At this point, the dollar sign prompt "\$" will be returned to the computer screen. The datalogger connected to the EOL modem is now in the Telecommunications Mode and will respond to the standard datalogger telecommunications commands. If the verification block does not return shortly, pressing [ENTER] will cause the SOL modem to return to the Local Command Mode.

4.1.7.2 Maintaining the RF Link

Data can be transferred once the RF link is established. Data blocks are created and transmitted by the SOL and EOL modems according to the following two rules. First, characters received on the Serial I/O port are placed into data blocks of 238 characters each. The block is then closed and transmitted. Any remaining or new characters received at this point are placed into a new data block. Second, if during this loading process a delay of 290 ms occurs between characters, the data block will be closed and transmitted.

Most of the time, the SOL modem will be sending command strings which will be answered by the EOL modem and the datalogger. The response from the datalogger is not instantaneous. If a command is sent before the response from the previous command has been received, the current command will be sent and a possible collision of the RF signal may occur. This results in a loss of the response and the current command. The general rule is that the person sending characters should wait for the response to come back before issuing further commands.

4.1.7.3 Shutting Down the RF Link

Sending the "E" character to a datalogger causes the datalogger to drop its ME line, which causes a shutdown of the RF link.

A shutdown block is created by the EOL modem which can be sent to the computer as an indicator of communication quality. The shutdown block consists of three RF Link Quality Accumulators (RLQA). Each RF95 in the link will have three RLQAs which are appended to the shutdown block. The RLQA from each RF95 are representative of the active period of the link. The first three RLQAs represent the EOL modem connected to the datalogger, the following sets of numbers will be for any MOL modems (in order of occurrence from the EOL modem), and last will be the SOL modem. A description of the shutdown block is contained in Table 4-3.

TABLE 4-3. Summary of the Shutdown Block

xxxx yyyy zzzz	
xxxx	= Number of communication failures.
yyyy	= Noise level indicator.
zzzz	= Noise level indicator.

A communication failure occurs when a signature of a block of data doesn't match its original signature. These blocks are subsequently retransmitted. The noise level indicators should be 102 (± 70) at the standard 3.0K baud rate, or 124 (± 70) at 2.4K baud.

The noise level indicators are reset and subsequently become active in the respective EOL and SOL modems as the Transparent Mode is entered (immediately after setup). The MOL modems are reset and become active when the setup block is propagated to the next station in the RF link.

After the "E" character is received by the datalogger a CR-LF is sent through the RF link to the SOL modem. The shutdown block follows after a one second delay. When the shutdown block is received and verified the SOL modem will leave the Transparent Mode and re-enter the Local Command Mode, indicated by sending an exclamation point (!) to the computer.

The shutdown block can be viewed by sending the "R" command. Example 4-2 illustrates a shutdown block for three RF95s.

EXAMPLE 4-2. Sample Shutdown Block

```

IR
EOL modem - > 0004 0110 0097
MOL modem - > 0002 0108 0090
SOL modem - > 0000 0105 0093
!
```

The first line of numbers, which are the first three RLQAs, represent the EOL modem. The second line represents a MOL modem, and last is the RLQAs for the SOL modem. The 0004 indicates that four interruptions occurred on the EOL modem while the link was active. Interruptions are non-data blocks such as voice transmissions on the same carrier frequency. All noise level indicators are within acceptable bounds in this example.

SECTION 4. RADIOTELEMETRY NETWORK COMPONENTS

The "T" command should now be used to reset the SOL modem to the Wait Mode of operation. This step should not be done if further calls are going to be made through a phone modem.

4.1.8 RF95 PIN DESCRIPTIONS

The 9 pin Serial I/O connector is normally used to connect the RF95 to the datalogger, or to the PS512M. Table 4-4 describes the pin connections.

TABLE 4-4. Serial I/O Connector Description

Pin	Description
1	+5 V: Supply from external source
2	GND: Ground
3	Ring: Ring to datalogger
4	RXD: Transmit from RF95
5	ME: Modem Enable from datalogger
6	Printer Enable: Not used
7	Unload Enable: Not used
8	Tape Enable: Not used
9	TXD: Received by RF95

The ten pin rectangular connector is for connection to the transceiver. Table 4-5 contains the pin descriptions.

TABLE 4-5. Transceiver Port Pin Description

Pin	Description
1	Transceiver RXD: From transceiver
2	GND: Ground
4	Not used
5	Transceiver TXD: To transceiver
6	Transceiver TXD Return
7	Not used
8	Not used
9	Receive/Transmit Control
10	Receive/Transmit Control Return

4.2 RADIO

The P50 Radio transmits and receives data blocks. The volume, squelch, and frequency controls on the radio must be set properly.

4.2.1 VOLUME CONTROL

The volume control should be set to approximately 1/2 of the operational range. This is equivalent to approximately 9:00 assuming the off position is at 4:00. Marginal RF links can be enhanced by "fine tuning" the volume control at any respective RF station. For more information see Section 4.1.7.3 Shutting Down the RF Link for a description of communication quality (RLQA) numbers.

4.2.2 SQUELCH CONTROL

The squelch control determines the input power level that the radio will break squelch. The squelch control should be set fully clockwise, or approximately 12:30.

4.2.3 FREQUENCY SWITCH

The frequency switch should always be set to 1, unless you are using a dual frequency system. Refer to Section 5.2 "Special Applications" for further information on the use of dual frequencies.

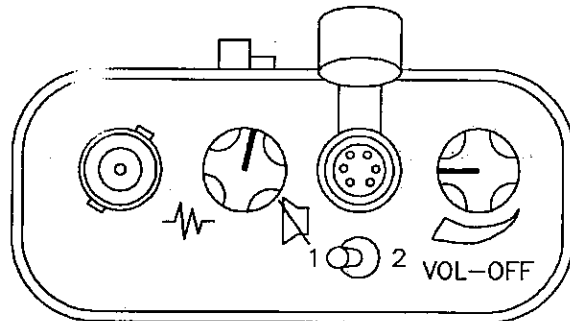

FIGURE 4-3. P50 Radio Settings

SECTION 4. RADIOTELEMETRY NETWORK COMPONENTS

4.2.4 P50 SPECIFICATIONS

	<u>VHF</u>	<u>UHF</u>
Power Output	5W	4W
Frequency (MHz)	30-50, 150-174	425, 450-470
Channel Capability	2	2
Dimensions	6.7"x2.5"x1.2"	6.7"x2.5"x1.2"
Weight	15.5 oz	15.5 oz
FCC Designation	AZ489FT3729	AZ489FT4724
Modulation	16F3	16F3
<u>Current Drain</u>		
Quiescent	10 mA	1.35 A
Active	15 mA	1.10 A

4.3 POWER SUPPLY

A radiotelemetry network requires a reliable power supply at each station. A solar panel or 110/220 V AC charging source is normally required due to the large current drain of the radio.

4.3.1 LEAD ACID BATTERIES

Lead acid batteries are designed to be float charged by a solar panel or AC power source. The role of the lead acid battery is to supply power when the charging source is absent (e.g. in case of power failures (AC charging), or during times of zero charge with a solar panel).

21XL and CR7 lead acid batteries do not have the required capacity for a typical RF station, they are only 2.5 Amp Hour batteries. Generally, we recommend a minimum of 5 Amp Hour batteries.

4.3.2 PS12-LA LEAD ACID POWER SUPPLY

The PS12-LA power supply includes a 12V, 7.0 amp-hour lead acid battery, an AC transformer (20V), and a temperature compensated charging circuit with a charge indicating diode. An AC transformer or solar panel should be connected to the PS12 at all times. The charging source trickle charges the lead acid batteries which power the datalogger. The internal lead acid battery continues to power the datalogger if the charging source is interrupted. The PS12-LA specifications are given in Table 4-6.

The two leads from the charging source can be inserted into either of the CHG ports, polarity doesn't matter. A transzorb provides transient protection to the charging circuit. A sustained

input voltage in excess of 40V will cause the transzorb to limit voltage.

Some solar panels are supplied with a connector, this connector must be clipped off so the two wires can be inserted into the two terminal ports. It is recommended that these two leads be stripped and tinned.

The red light (LED) on the PS12-LA is on during charging. The switch turns power on and off from the 12V ports, battery charging still occurs when the switch is off.

CAUTION: Switch the power to "off" before disconnecting or connecting the power leads to the Wiring Panel. The Wiring Panel and PS12-LA are at power ground. If 12V is shorted to either of these, excessive current will be drawn until the thermal fuse opens.

The external port, labeled EXT, is not meant to be used with the PS12-LA. The primary power source is the charging source, and the secondary power source is the internal lead acid battery. Connecting a lead acid battery to the external source is the same as connecting two lead acid batteries in parallel, causing one battery to drop voltage and the other to raise voltage. Alkaline batteries connected to the external port would be charged by the charging source which can cause an explosion.

CAUTION: Do not use the external port, labeled EXT, with the PS12-LA.

SECTION 4. RADIOTELEMETRY NETWORK COMPONENTS

Monitor the power supply using datalogger Instruction 10. Users are strongly advised to incorporate this instruction into their data acquisition programs to keep track of the state of the power supply. If the system voltage level consistently decreases through time, some element(s) of the charging system has failed. Instruction 10 measures the voltage at the 12V port, not the voltage of the lead acid battery. External power sources must be disconnected from the CR10 and charging circuit in order to measure the actual lead acid battery voltage.

TABLE 4-6. PS12-LA Battery and AC Transformer Specifications

Lead Acid Battery	
Battery Type	Yuasa NA 7-12
Float Life @ 25°C	5 years typical
Capacity	7.0 amp-hour
Shelf Life, full charge	Check twice yearly
Charge Time (AC Source)	40 hr full charge, 20 hr 95% charge
AC Transformer	
Input:	120V AC, 60 Hz
Isolated Output:	20V DC @ 350 mA max.

CAUTION: Users are reminded of the inherent hazards associated with the use of lead acid batteries. Under normal operation, lead acid batteries generate a small amount of hydrogen gas. This gaseous product is generally insignificant because it dissipates naturally before it accumulates to an explosive level (4%). However, if the batteries are shorted or overcharging takes place, hydrogen gas may be generated at a rate sufficient to create a hazard. Because the potential for excessive hydrogen build-up exists, Campbell Scientific makes the following recommendations:

- a) The BP10 should not be used in environments requiring intrinsically safe equipment (e.g. coal mines).
- b) The BP10 should not be used while in a tightly sealed enclosure.
- c) Insulate the positive lead against accidental shorting while routing power leads.

4.3.3 PS512 M VOLTAGE REGULATOR WITH NULL MODEM PORTS

The PS512 M 12 Volt Lead Acid Power Supply with Charging Regulator and Null Modem Ports is used when 5 volts is needed to power external modems besides the capabilities of the PS12-LA. The PS512 M supplies 5 volts to pin 1 of the 9 pin null modem ports, otherwise the capabilities and functions are identical to the PS12-LA. A common use for the PS512 M is in radiotelemetry networks. The PS12-LA cannot be modified to a PS512 M.

The maximum current drain on the 5 volt supply of the PS512 M is 150 milliamps.

4.4 ANTENNAS AND CABLES

Antennas radiate and receive the radio signals. Each radio in a radiotelemetry system must have an antenna. Coax cable is used to connect the antenna to the radio.

4.4.1 ANTENNA INSTALLATION

Antennas have various mounting options. Listed below are the mounting specifications for several antennas.

4.4.1.1 Antenna Mounts

The antenna PD688S utilizes two U bolts to connect to a vertical pipe with O.D. of 1 5/16"-2 3/8". The antennas BA6012, BA6312, BA1012, and BA1312 use two U bolts to mount to a 1"-2 1/4" O.D. vertical pipe. The antennas BA6110 and BA1010 have U bolts to mount to a 3/4"-2 1/8" O.D. vertical pipe.

The antennas PD1121 and PD344 have stainless steel clamps which mount to a 2 1/2" O.D. pipe.

The antennas PD390S, PD1158S, PD156S, PD688D, PD156D, PD390D, and PD1158D use the PD237 Crossover Plate which secures the antenna to a vertical pipe of the sizes: 1 5/16", 1 15/16", or 2 3/8" O.D. Figure 4-6 displays this connection.

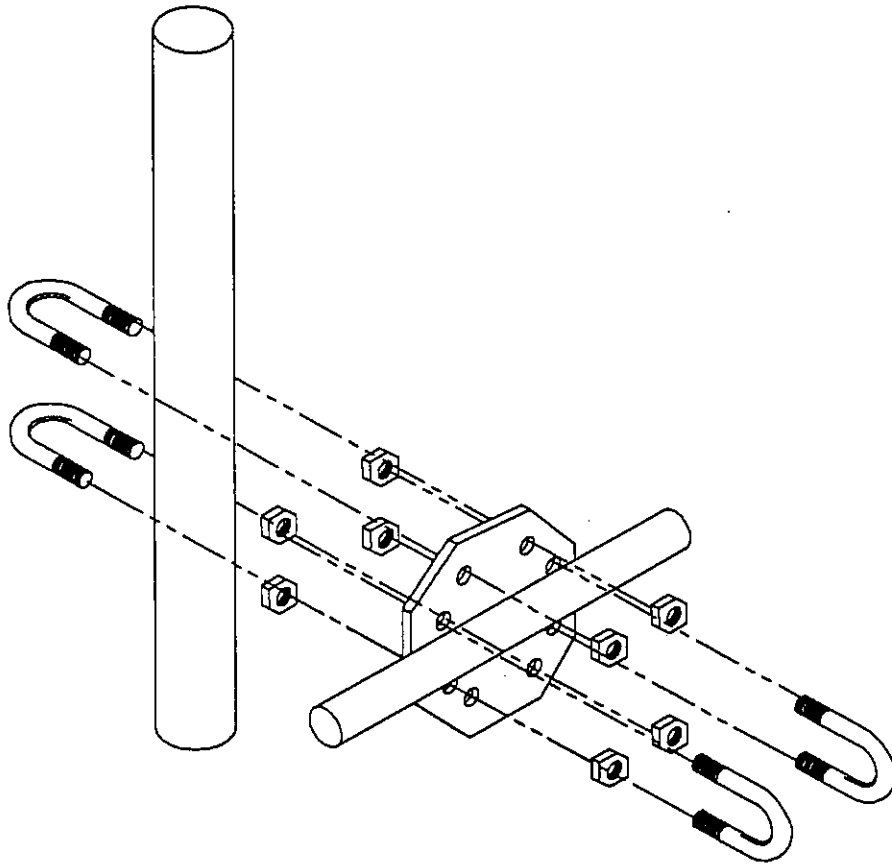

FIGURE 4-4. The PD237 Crossover Plate Antenna Mount

The antennas PD200, PD201, PD220, PD399, PD400, PD455, PD458, PD10036, PD10037, PD1108, PD1109, PD1110, PD1150, PD1151, PD10036, PD10037, and PD10041 use the PD46 Clamp Mounts. These clamps should be tightened around both the antenna mounting base and a vertical pipe of O.D. from 1" to 2 3/4". Figure 4-7 shows a diagram of these mounts.

The model numbers listed refer to Celwave antennas. Specific questions regarding antenna mounting can be directed to Campbell Scientific, Inc. or Celwave. For information, Celwave's address follows.

Celwave
Route 79
Marlboro, NJ 07746
(201) 462-1880

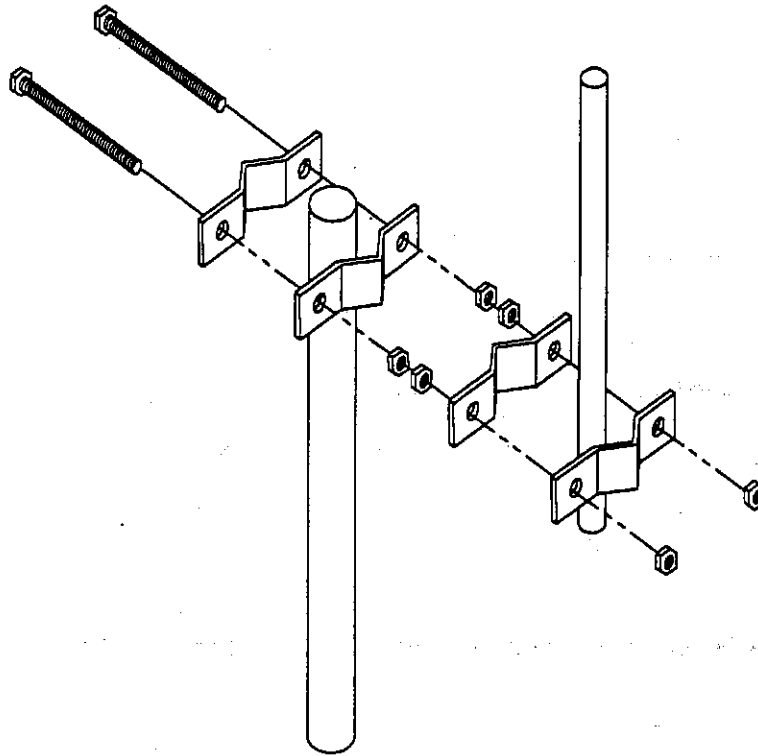

FIGURE 4-5. The PD46 Clamp Mount

4.4.1.2 Antenna Orientation

Before installation is complete, the orientation of the antenna must be correct. First determine if your antenna is omni-directional or unidirectional. An omni-directional antenna will transmit/receive in a full 360 degree circle. A unidirectional antenna is designed to transmit/receive in a particular direction, or in a specified sector.

Generally, an omni-directional antenna will be a straight cylindrical rod which is to be mounted vertically at the top of a tripod (see Figure 2-5).

There are various shapes of unidirectional antennas. The most common is the Yagi antenna (see Figure 2-1). The elements of a Yagi antenna can be mounted either vertically or horizontally. Corresponding to either vertical or horizontal polarization. Normally, all antennas will be mounted with vertical polarization. Whichever polarization is used, be sure to keep all antennas identically polarized.

4.4.2 ANTENNA CABLES AND CONNECTORS

The most common cable type to connect a radio to the antenna is a coaxial RG-8A/U cable.

Two connectors are required for each length of cable. The connector for the radio is a BNC type connector. The connector for the antenna is usually either a Type-NM or Type-NF. The BNC, Type-NM, and Type-NF connectors are shown in Figure 4-8. The Type-NM (male) connector is for antennas with a female receptacle, and Type-NF (female) for antennas with male receptacles.

A cable complete with connectors is specified as either COAX BNC NM, or COAX BNC NF. COAX BNC NF is a coaxial RG-8A/U cable with a BNC connector on one end and a Type-NF connector on the other.

Table 4-6 lists antennas that use Type-NF and those that use Type-NM. Common antenna characteristics are also listed.

Due to power loss through the cable, the length of coax cable cannot be extended to any desired length. The amount of power loss is dependent on the radio frequency. RG-8A/U will lose

SECTION 4. RADIOTELEMETRY NETWORK COMPONENTS

approximately 3.1 dB/100 ft. at 200 MHz and 5.0 dB/100 ft. at 400 MHz. Power loss calculations

are reviewed in Appendix B.

TABLE 4-7. Common Antennas and Characteristics

<u>Antenna</u>	<u>Type</u>	<u>VHF/UHF</u>	<u>Cable</u>	<u>Gain(dB)</u>
BA1010	Omni	VHF	Coax BNC NM	Unity
BA1012	Omni	VHF	Coax BNC NM	Unity
BA1312	Omni	VHF	Coax BNC NM	3.0
BA6012	Omni	UHF	Coax BNC NM	Unity
BA6312	Omni	UHF	Coax BNC NM	3.0
PD200	Omni	VHF	Coax BNC NF	5.8
PD201	Omni	UHF	Coax BNC NF	5.0
PD220	Omni	VHF	Coax BNC NF	5.25
PD344	Dipole	VHF	Coax BNC NF	4.5
PD390S	Yagi	VHF	Coax BNC NF	8.0
PD400	Omni	VHF	Coax BNC NM	7.5
PD440	Omni	VHF	Coax BNC NF	3.0
PD620	Omni	VHF	Coax BNC NF	5.25
PD688S	Yagi	UHF	Coax BNC NF	10.0
PD1107	Omni	VHF	Coax BNC NF	3.0
PD1121	Dipole	VHF	Coax BNC NF	3.0
PD1167	Omni	VHF	Coax BNC NF	3.0

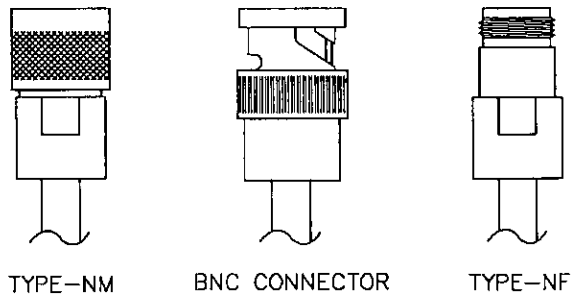

FIGURE 4-6. Type-NM (male), BNC, and Type-NF (female) Connectors

4.5 TRIPOD AND ENCLOSURES

There are several methods of mounting and housing sensors and equipment. Campbell Scientific, Inc. offers the CM10 and CM6 Tripods, and several enclosures for our dataloggers. The following sections explain the standard options available.

4.5.1. GENERAL

The CM10 and CM6 Tripods are general purpose instrument mounts. They are designed to provide sturdy support for common sensors, enclosures, and antennas.

The CM10 is a 10 ft. adjustable tripod, and the CM6 is a 6 ft. adjustable tripod.

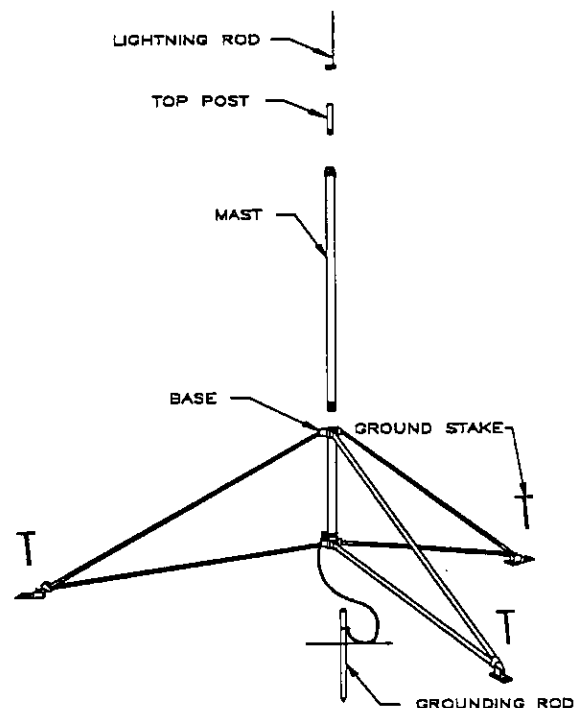

FIGURE 4-7. CM10/CM6 Tripod Assembly Drawing

SECTION 4. RADIOTELEMETRY NETWORK COMPONENTS

4.5.2. CM10 SPECIFICATIONS

Height
10 ft. (variable)
Weight
70 lbs.
Vertical Load Limit
100 lbs.
Mast
1 1/4 in. I.D. pipe
Tripod Base Radius
9" to 6' (Adjustable)
Leveling Adjustment
Individual leg slide collars
Leg Base
2" x 5" with 1/2" ground stake hole
Portability
Collapsible to 6' length x 9" dia.

4.5.3. CM6 SPECIFICATIONS

Height
6 ft. (variable)
Weight
45 lbs.
Vertical Load Limit
100 lbs.
Mast
1 1/4 in. I.D. pipe
Tripod Base Radius
9" to 6' (Adjustable)
Leveling Adjustment
Individual leg slide collars
Leg Base
2" x 4" with 1/2" ground stake hole
Portability
Collapsible to 4' length x 9" dia.

4.5.4. ASSEMBLY

The CM10/CM6 is assembled as shown in Figure 4-7. Accessories for the tripods are shown in Figure 4-8. Following are the accessories for the tripods which may be purchased separately:

019ALU	Sensor Crossarm Mount
015	Pyranometer Mounting Arm
025	Pyranometer Crossarm Stand
41004-5	12 Plate Gill Radiation Shield for 207 Probe
41002-2	12 Plate Gill Radiation Shield for HMP35C
41301-5	6 Plate Gill Radiation Shield

The 019ALU Crossarm connects to the tripod top post for mounting sensors such as pyranometers and wind sensors. The 015 Pyranometer Mounting Arm is used for mounting a pyranometer when both ends of the 019ALU Crossarm are used for other sensors. The 025 Pyranometer Crossarm Stand is the alternative pyranometer mount when only one end of the 019ALU Crossarm is being used for other sensors.

The 12 Plate 41004-5 and 41002-2 and the 6 Plate 41301-5 Gill Radiation Shields are housings for temperature and relative humidity sensors. The shields eliminate radiation loading of the sensors while also allowing ventilation. The size of the sensor determines whether a 12 plate or 6 plate shield is required.

The rain gauge is usually placed away from the tripod on a separate post or pipe, which is not provided.

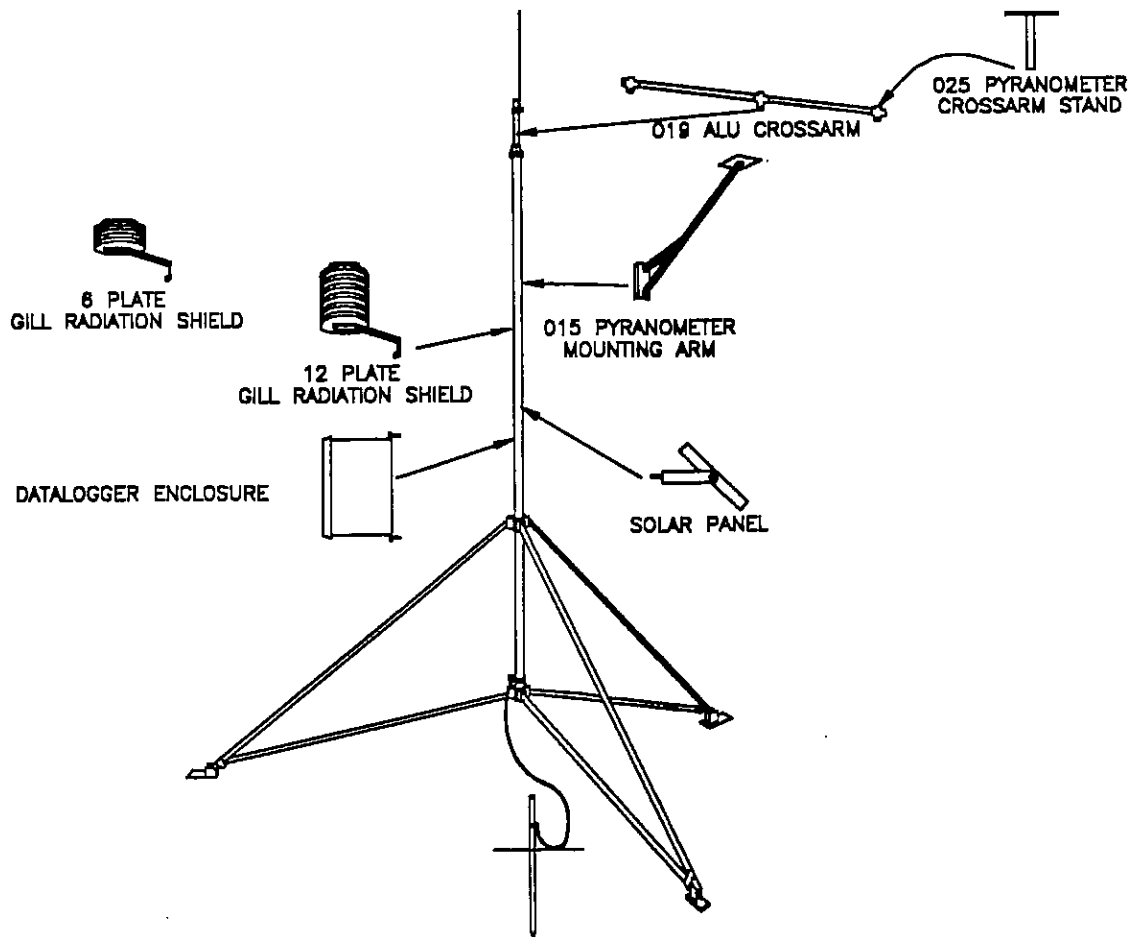

FIGURE 4-8. CM10/CM6 Tripod with Additional Accessories

4.5.5 ENCLOSURES

Enclosures are needed to keep water and debris from damaging the data acquisition equipment. Campbell Scientific, Inc. enclosures are designated as "raintight," and are designed to mount on a tripod. Following is a description of the standard enclosures.

4.5.5.1 CR10 and 21X Enclosures

Campbell Scientific offers two enclosures for housing a CR10 and peripherals. The fiberglass enclosures are classified as NEMA 4X (water-tight, dust-tight, corrosion-resistant, indoor and outdoor use). A 1.25" diameter entry/exit port is located at the bottom of the enclosure for routing cables and wires. The enclosure door can be fastened with the hasp for easy access, or with the two supplied screws for more permanent applications. The white plastic inserts at the corners of the enclosure must be removed to

insert the screws. Both enclosures are white for reflecting solar radiation, thus reducing the internal enclosure temperature.

The Model ENC 10/12 fiberglass enclosure houses the CR10, power supply, and one peripheral such as a Storage Module. Inside dimensions of the ENC 10/12 are 12"x10"x4.5", outside dimensions are 16"x11.5"x7" (with brackets); weight is 8.5 lbs.

The Model ENC 12/14 fiberglass enclosure houses the CR10, power supply, and one or more peripherals. Inside dimensions of the ENC 12/14 are 14"x12"x5.5", outside dimensions are 18"x13.5"x8.13" (with brackets); weight is 11.16 lbs.

SECTION 4. RADIOTELEMETRY NETWORK COMPONENTS

4.5.5.2 CR7 Enclosures

Most CR7 radiotelemetry applications have special needs depending on the individual system. The ENC-24 is normally used in CR7 RF applications. Figure 2-3 in Section 2 "The General Radiotelemetry Network" shows a typical system. Contact Campbell Scientific's Marketing Department for special applications.

4.6 RF232 BASE STATION

The three basic components to a base station are an IBM/IBM Compatible computer, the PC208 Datalogger Support Software, and the RF232 Base Station. A radio and antenna are also required.

This section covers the RF232 Base Station. Section 5 "Operation of the Radiotelemetry Network" provides starting information on the PC208 Datalogger Support Software. Refer to the PC208 Manual for complete instructions.

4.6.1 RF232 INTRODUCTION

The RF232 Base Station provides a "single box" desktop base station with the following features:

- Internal RF modem
- 25 Pin RS232 port for connection to IBM PC
- 110 VAC/12 VDC transformer, and mount for the base radio
- Easy access to radio for antenna cable connection

The RF232 Base Station includes a RF95 Modem with a carrier detect light. The RF95 Modem sits directly behind the RF232 front panel.

For a description of the Carrier Detect Light and the communication protocol, refer to Section 4.1 "RF95 Modem." The Station ID Number of the RF95 comes shipped from the factory at 1. Under most circumstances there is no need to change this address.

4.6.2 RADIO INSTALLATION

Disconnect the RF232 from AC power.

Remove the four phillips screws (two on each side) from the RF232 and remove the top cover. Insert the radio according to Figures 4-9 and 4-10. Secure the radio with the velcro strap.

The 12 volt power supply for the radio is on the green board at the inside rear of the RF232 (PCB P/N 4971). Connect the black ground wire of the radio to the "G" terminal on the board, and connect the red wire to the "12V" terminal.

Plug the rectangular connector of the radio, noted by the multicolored ribbon cable, into the keyed receptacle behind the front panel and above the "POWER ON" light.

Pass the antenna cable through the hole in the back of the RF232 and connect it to the radio.

The RF232's 25 pin female port connects to the computers 25 pin RS232 port. The RF232's 25 pin port is configured as Data Communications Equipment (DCE) for direct cable connection to Data Terminal Equipment (DTE) such as an IBM-PC serial port. Table 4-7 shows the pin description.

The volume, squelch, and frequency controls must be set properly. The volume control setting should be set to approximately 9:00 assuming the off position is at 4:00. The squelch control setting should be set fully clockwise. The frequency switch should be set to 1. Replace the RF232 cover. For further details, refer to Section 4.2 "Radio".

4.6.3 220, 230, AND 240 VAC CONVERSION

The RF232 can be used with 220, 230, or 240 VAC if a small wiring modification is done.

First disconnect any AC power! Lift the cover off of the RF232 and locate the power supply (P/N 4918) as shown in Figure 4-10. Unscrew the four phillips head screws on top of the power supply and turn the power supply upside down. The wire ties holding the power supply leads to the base must be clipped.

With the power supply on its back, locate pins 1, 2, 3, 4, and 5. The power supply is shipped from the manufacturer configured for 120 VAC with pins 1 and 3 jumpered, pins 2 and 4 jumpered, and AC power coming onto pins 1 and 4. These connections must be desoldered. Table 4-8 shows the proper connections for 110, 120, 220, 230, and 240 VAC.

SECTION 4. RADIOTELEMETRY NETWORK COMPONENTS

TABLE 4-8. RF232 Power Conversions

	Pins Jumpered	Apply AC
110 VAC	1-3, 2-4	1-4
120 VAC	1-3, 2-4	1-4
220 VAC	2-3	1-5
230 VAC	2-3	1-4
240 VAC	2-3	1-4

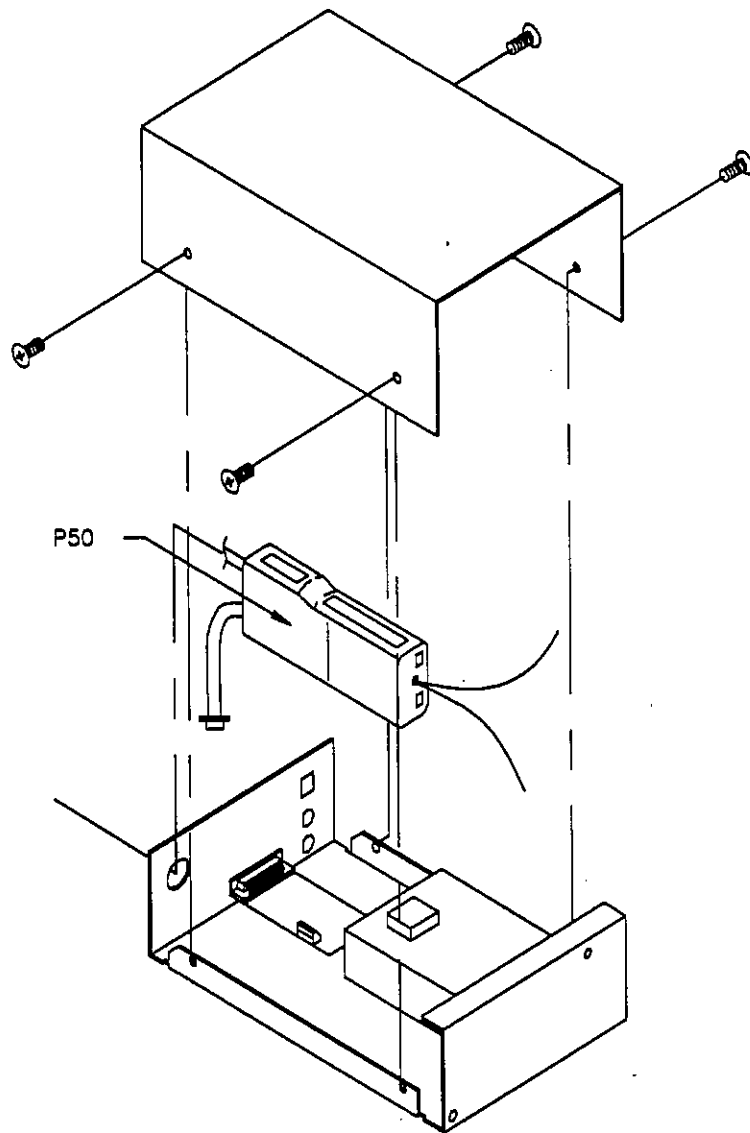

FIGURE 4-9. The RF232 Base Station

SECTION 4. RADIOTELEMETRY NETWORK COMPONENTS

RF232 TOP VIEW

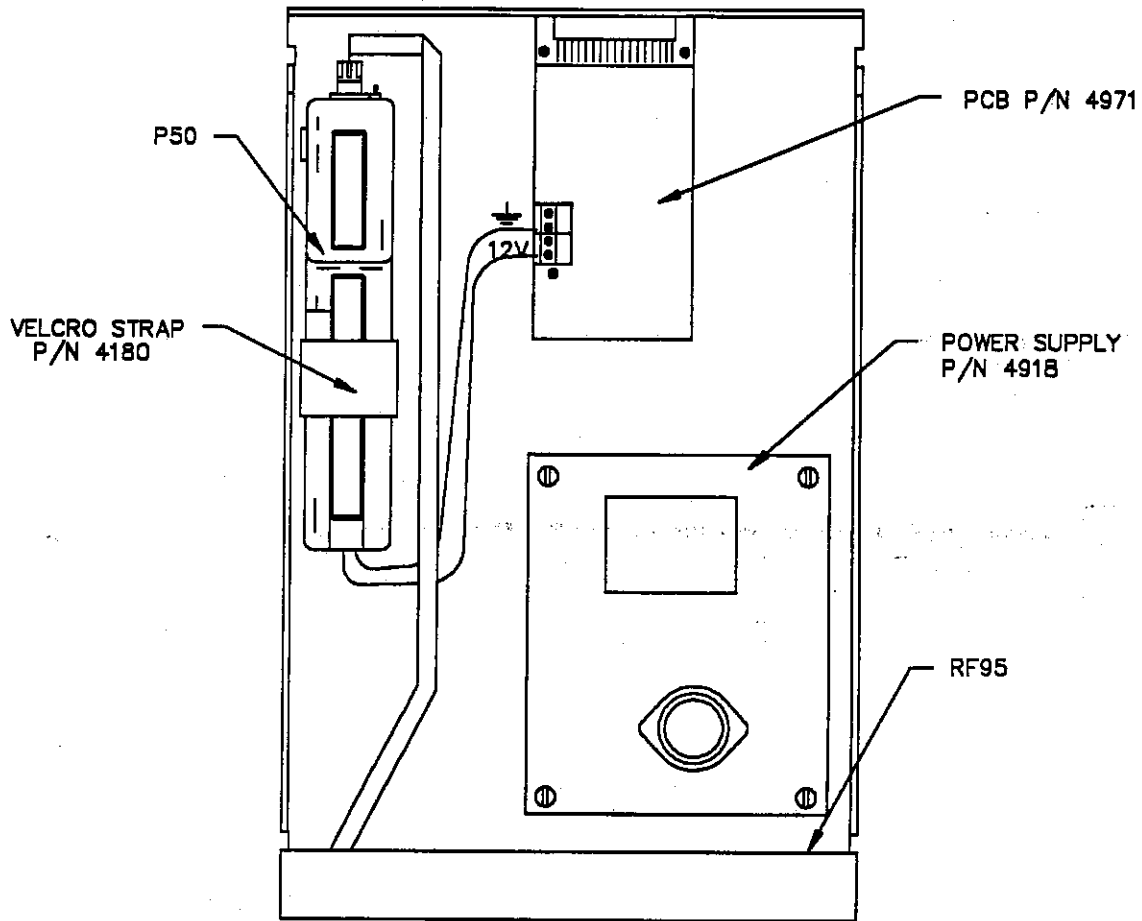

FIGURE 4-10. Top View of the RF232 Base Station

TABLE 4-9. Pin Description for RF232's 25 Pin Port

<u>Pin</u>	<u>I/O</u>	<u>Description</u>
1	-	Ground
2	I	TX
3	O	RX
4	I	RTS
20	I	DTR
22	O	RING

Pin = Pin number

I = Signal into the RF232

O = Signal out of the RF232

SECTION 5. OPERATION OF THE RADIOTELEMETRY NETWORK

All field stations can be accessed and monitored from the central base site. Regular visits to the field sites are required to ensure that all sensors are in place, enclosures are dry, solar panel is clean, and that the tripod and antenna are secure. Frequency of visits to the field sites are variable depending on environmental conditions and the sensors utilized.

This section of the manual includes a description of the PC208 Datalogger Support Software as it applies to RF applications, as well as a description of some special RF applications.

5.1 MONITORING AND COLLECTING DATA - PC208 RF NOTES

The PC208 Datalogger Support Software is the key to communicating with the field stations. Complete information on the PC208 Software is included in the PC208 Manual. This section gives a brief description of data collection methods, and provides specific RF application notes.

5.1.1 COLLECTING DATA - TELCOM

TELCOM is the program for data collection. The user is required to complete a Station File which stores information such as the frequency of data collection, the datalogger type at the field station, the communication baud rate, the COM port, and the RF path.

Rather than collecting data from each field station separately, it is most efficient to create one Script File (similar to a batch file) to retrieve data from several stations. The next two subsections describe the Station File and Script File, respectively.

5.1.1.1 The Station File

A Station File must be created for each field station. The following questions must be answered in a Station File; options obtained by hitting the spacebar are in parenthesis.

Datalogger or Command Type: (CR10, 21X, CR7, CR21, DSP4, DOS Command, Exit TELCOM)

Data Collection Method: (Since Last Call-Append File, Since Last Call-Create File, Most Recent Arrays-Create, Most Recent Arrays-Append)

Nbr of Arrays to Backup on First Call:

Data File Format: (Comma Delineated ASCII, Printable ASCII, Same as Received From Datalogger)

Fix Datalogger Clock Using PC Clock: (No, Check Only and Report When 30 seconds off, When 30 seconds off)

Primary Call Interval (minutes):

Recovery Call Interval (minutes):

Repetitions of Recovery Interval #1:

Recovery Call Interval #2 (minutes):

Maximum Time Call Will Take (minutes):

Interface Devices: (COM Port, Hayes Modem, MD9, RF Modem, Short Haul Modem, SMX126 Multiplexer)

Questions on any of these parameters are explained in the PC208 Manual.

Two options under 'Interface Devices' will be utilized in a simple RF application. These are the COM port and the RF modem. The COM port specification is needed to access the proper RS232 port of your computer. The communication baud rate must be entered with the 'COM Port' option. The RF95 in the RF232 supports 9600 baud communication between the computer and the RF95.

When the 'RF Modem' option is chosen, a prompt for 'Path' will appear. The RF path for any particular field station consists of the Station IDs which are in the link from the base station to the field station, excluding the base station ID number. If no repeaters are used in a link, then

SECTION 5. OPERATION OF THE RADIOTELEMETRY NETWORK

the RF path will have only one number which is the Station ID of the field station. If there is one repeater, then two numbers are required with a space, or comma, separating the two. The numbers listed should be the Station IDs of the repeater and field station, respectively. The Station IDs must be in the order of occurrence from the base station, and the entire path cannot exceed 40 characters.

The letter F may be added to the end of the path designation to speed communication. Example 5-1 shows an example of an RF path designation to communicate to a field station through 1 repeater. In this case, the repeater has a Station ID of 10 and the field station an ID of 95.

EXAMPLE 5-1. Sample RF Path Designation

Interface Device:

```
COM1          Baud Rate:9600
RF Modem      Path:10 95F
End
```

This example assumes use of communication port 1, and the Station IDs shown.

Refer to the TELCOM section of the PC208 Manual for a description of the other parameters.

Following the creation of the Station File, type "TELCOM name/C" to collect data from the field station, where "name" is the name of the Station File. For example, data can be collected using Station File RFTEST by typing "TELCOM RFTEST/C". The data will be stored in a file called RFTEST.dat. The "/C" option after RFTEST forces TELCOM to call the station NOW whether or not it is time to call according to the calling interval specified in the Station File. Typing "TELCOM RFTEST" without the "/C" will call the field station only if the required time between calls has passed.

5.1.1.2 The Script File

The Script File contains a list of Station Files which are called sequentially for data collection without leaving TELCOM. The Script File is more than a simple batch file. Within the Script File, datalogger calls are optimized and telecommunication control instructions are executed.

To edit a Script File, type "TELCOM name.SCR/E", where "name" is any Script File name. The extension .SCR must be entered when editing or TELCOM will assume the file is a Station File.

Attended operation allows data collection at any time. Assume there are three field stations in the network with names of HILL1, MTN, and CRK; also assume the Script File is named CALLALL. The Script File would be as follows.

EXAMPLE 5-2. Script File Attended Data Collection

```
HILL1/C
MTN/C
CRK/C
```

All of the stations could then be called by simply typing "TELCOM CALLALL". The data would be collected and stored in files named HILL1.dat, MTN.dat, and CRK.dat according to the Station File name of each site.

Unattended operation allows data collection at specified intervals. The PC201 Card and a PC203 Power-Up Control Box are required for powering the computer on and off in the unattended mode. In this case, the /D command is used at the end of the Script File to shut off the computer after calling.

However, if the computer is left on, the PC201 and PC203 are not required. Without the PC201 Card and the PC203 Control Box, a Script File is used with the "/W" wait option. The wait option is entered at the end of the Script File. Example 5-3 shows a Script File which will call the RF Station, and then wait for the next time to call.

EXAMPLE 5-3. Script File - Unattended Data Collection

With PC201, PC203

```
HILL1
MTN
CRK
/D
```

Without PC201, PC203

```
HILL1
MTN
CRK
/W
```

Further details of attended and unattended data collection are explained in the PC208 Manual.

SECTION 5. OPERATION OF THE RADIOTELEMETRY NETWORK

5.1.2 GENERAL COMMUNICATION TERM

With the use of TERM, a terminal emulator program, it is possible to download programs to the datalogger and monitor the Input Locations of the datalogger. TERM has other capabilities which are explained in the PC208 Manual, but these two capabilities are commonly needed in an RF network.

5.1.2.1 Download Datalogger Programs

It is possible to create datalogger programs with EDLOG and then download the program to the datalogger from the base station. This saves the user from having to travel to the field station to program the datalogger.

EDLOG is a program within PC208 to create datalogger programs. The use of EDLOG is explained in the PC208 Datalogger Support Software Manual. Once the datalogger program has been created with EDLOG, it is ready to be downloaded to the datalogger.

TERM uses a Station File similar to TELCOM; however, TERM utilizes parameters from TELCOM's Station File if the TELCOM Station File has already been created. Type "TERM name/E" to view the TERM Station File, where "name" is the Station File name. Correct the Station File, if needed, and then save the file.

A list of options will appear on the screen. Download the program by selecting the "D" option. When prompted, type the name of the program to be downloaded, press [ENTER], and wait for the transfer to be completed.

5.1.2.2 View Real-Time Measurements

The Monitor Mode of TERM is used to view results of instantaneous measurements. Type "TERM name/E" to view the TERM Station File, where "name" is the name of the Station File. Correct the Station File, if needed, and then save the file.

A list of options will appear on the screen, choose "M" to monitor the Input Locations. The input Locations that are displayed can be

changed by using the 'Locations Displayed' option at the bottom of the Monitor Mode display.

The Monitor Mode updates the Input Locations frequently requiring a lot of transmission time. Due to the high current drain of the radios during transmission, it is not recommended to use this form of communication for long periods of time when a solar panel is being utilized at the field station.

5.2 SPECIAL APPLICATIONS

5.2.1 DATALOGGER INITIATED COMMUNICATIONS

The datalogger can call the computer to initiate data collection, sometimes termed "call back." Instruction 97, Initiate Telecommunications, is used for this purpose. Call back is commonly used to initiate data collection under emergency situations (e.g. water level falls below lower limit).

When the PC201 Card and PC203 Power-up box are used, the base station computer can be turned off. The datalogger will call the PC201 card, the computer will be powered up, data collected, and the computer may then be automatically shut off.

Without the PC201 Card and PC203 Power-Up Box, the computer must be left on and dedicated to RF communication to implement the call back option.

Call back instructions are explained in the datalogger manual. The PC208 Manual explains the use of call back in a telecommunications network.

5.2.2 DUAL FREQUENCY OPERATIONS

The P50 Radio is capable of receiving/transmitting at two separate frequencies. Both frequencies must be specified at the time of ordering the radios. The frequency switch on top of the radio will switch the radio from one frequency to another. One frequency should be used exclusively for data communication.



APPENDIX A. SETTING THE STATION ID

Each RF modem has nine dip switches, the first eight must be set for a particular Station ID. Following is a list of all possible Station IDs with the corresponding setting of the dip switches. One represents open, zero closed, and X "don't care."

SWITCHES			SWITCHES			SWITCHES		
ID	1234	56789	ID	1234	56789	ID	1234	56789
0	0000	0000X	43	1101	0100X	86	0110	1010X
1	1000	0000X	44	0011	0100X	87	1110	1010X
2	0100	0000X	45	1011	0100X	88	0001	1010X
3	1100	0000X	46	0111	0100X	89	1001	1010X
4	0010	0000X	47	1111	0100X	90	0101	1010X
5	1010	0000X	48	0000	1100X	91	1101	1010X
6	0110	0000X	49	1000	1100X	92	0011	1010X
7	1110	0000X	50	0100	1100X	93	1011	1010X
8	0001	0000X	51	1100	1100X	94	0111	1010X
9	1001	0000X	52	0010	1100X	95	1111	1010X
10	0101	0000X	53	1010	1100X	96	0000	0110X
11	1101	0000X	54	0110	1100X	97	1000	0110X
12	0011	0000X	55	1110	1100X	98	0100	0110X
13	1011	0000X	56	0001	1100X	99	1100	0110X
14	0111	0000X	57	1001	1100X	100	0010	0110X
15	1111	0000X	58	0101	1100X	101	1010	0110X
16	0000	1000X	59	1101	1100X	102	0110	0110X
17	1000	1000X	60	0011	1100X	103	1110	0110X
18	0100	1000X	61	1011	1100X	104	0001	0110X
19	1100	1000X	62	0111	1100X	105	1001	0110X
20	0010	1000X	63	1111	1100X	106	0101	0110X
21	1010	1000X	64	0000	0010X	107	1101	0110X
22	0110	1000X	65	1000	0010X	108	0011	0110X
23	1110	1000X	66	0100	0010X	109	1011	0110X
24	0001	1000X	67	1100	0010X	110	0111	0110X
25	1001	1000X	68	0010	0010X	111	1111	0110X
26	0101	1000X	69	1010	0010X	112	0000	1110X
27	1101	1000X	70	0110	0010X	113	1000	1110X
28	0011	1000X	71	1110	0010X	114	0100	1110X
29	1011	1000X	72	0001	0010X	115	1100	1110X
30	0111	1000X	73	1001	0010X	116	0010	1110X
31	1111	1000X	74	0101	0010X	117	1010	1110X
32	0000	0100X	75	1101	0010X	118	0110	1110X
33	1000	0100X	76	0011	0010X	119	1110	1110X
34	0100	0100X	77	1011	0010X	120	0001	1110X
35	1100	0100X	78	0111	0010X	121	1001	1110X
36	0010	0100X	79	1111	0010X	122	0101	1110X
37	1010	0100X	80	0000	1010X	123	1101	1110X
38	0110	0100X	81	1000	1010X	124	0011	1110X
39	1110	0100X	82	0100	1010X	125	1011	1110X
40	0001	0100X	83	1100	1010X	126	0111	1110X

APPENDIX A. SETTING THE STATION ID

SWITCHES			SWITCHES			SWITCHES		
ID	1234	56789	ID	1234	56789	ID	1234	56789
41	1001	0100X	84	0010	1010X	127	1111	1110X
42	0101	0100X	85	1010	1010X	128	0000	0001X
129	1000	0001X	172	0011	0101X	215	1110	1011X
130	0100	0001X	173	1011	0101X	216	0001	1011X
131	1100	0001X	174	0111	0101X	217	1001	1011X
132	0010	0001X	175	1111	0101X	218	0101	1011X
133	1010	0001X	176	0000	1101X	219	1101	1011X
134	0110	0001X	177	1000	1101X	220	0011	1011X
135	1110	0001X	178	0100	1101X	221	1011	1011X
136	0001	0001X	179	1100	1101X	222	0111	1011X
137	1001	0001X	180	0010	1101X	223	1111	1011X
138	0101	0001X	181	1010	1101X	224	0000	0111X
139	1101	0001X	182	0110	1101X	225	1000	0111X
140	0011	0001X	183	1110	1101X	226	0100	0111X
141	1011	0001X	184	0001	1101X	227	1100	0111X
142	0111	0001X	185	1001	1101X	228	0010	0111X
143	1111	0001X	186	0101	1101X	229	1010	0111X
144	0000	1001X	187	1101	1101X	230	0110	0111X
145	1000	1001X	188	0011	1101X	231	1110	0111X
146	0100	1001X	189	1011	1101X	232	0001	0111X
147	1100	1001X	190	0111	1101X	233	1001	0111X
148	0010	1001X	191	1111	1101X	234	0101	0111X
149	1010	1001X	192	0000	0011X	235	1101	0111X
150	0110	1001X	193	1000	0011X	236	0011	0111X
151	1110	1001X	194	0100	0011X	237	1011	0111X
152	0001	1001X	195	1100	0011X	238	0111	0111X
153	1001	1001X	196	0010	0011X	239	1111	0111X
154	0101	1001X	197	1010	0011X	240	0000	1111X
155	1101	1001X	198	0110	0011X	241	1000	1111X
156	0011	1001X	199	1110	0011X	242	0100	1111X
157	1011	1001X	200	0001	0011X	243	1100	1111X
158	0111	1001X	201	1001	0011X	244	0010	1111X
159	1111	1001X	202	0101	0011X	245	1010	1111X
160	0000	0101X	203	1101	0011X	246	0110	1111X
161	1000	0101X	204	0011	0011X	247	1110	1111X
162	0100	0101X	205	1011	0011X	248	0001	1111X
163	1100	0101X	206	0111	0011X	249	1001	1111X
164	0010	0101X	207	1111	0011X	250	0101	1111X
165	1010	0101X	208	0000	1011X	251	1101	1111X
166	0110	0101X	209	1000	1011X	252	0011	1111X
167	1110	0101X	210	0100	1011X	253	1011	1111X
168	0001	0101X	211	1100	1011X	254	0111	1111X
169	1001	0101X	212	0010	1011X	255	1111	1111X
170	0101	0101X	213	1010	1011X			
171	1101	0101X	214	0110	1011X			

APPENDIX B. ALTERNATE BASE STATION CONFIGURATIONS

The basic base station consists of a computer and the RF232 Base Station. There are other options for a base station including a portable base station, a phone-to-RF base station, and a phone-to-RF base station with measurement capability.

B.1 THE PORTABLE BASE STATION

The portable base station is an aid in setting up a large radiotelemetry network, or in troubleshooting RF network communication problems. A portable base station allows any of the field or repeater stations to act as a base station. Therefore, to try any particular RF link it is not necessary to travel back to the fixed base station.

Figure B-1 is a block diagram of a portable base station. The computer, with PC208 installed, is

the user interface to the RF network. Remember that the "RF Path" designation will be changed often to test various RF links. The SC532 is the interface from the laptop computer to the RF95 Modem. The transformer on the SC532 should be cut off 6" up the cable. The two leads on the SC532 should be stripped and tinned for connection to a battery. Most laptops have a 9 pin RS232 port so a 9 to 25 pin RS232 cable is needed to connect the computer to the SC532.

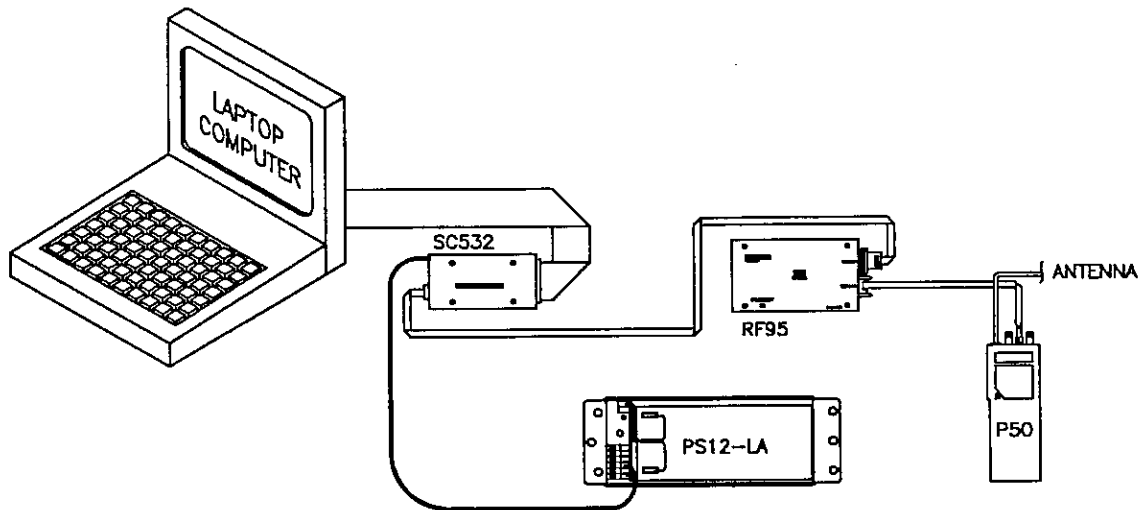

FIGURE B-1. Portable Base Station

B.2 PHONE-TO-RF BASE STATION

When an RF network is a great distance from the desired place of data collection, a phone modem can be used to call the RF base station. A computer, with PC208 Datalogger Support Software, and a Hayes phone modem can call a phone-to-RF base station. The configuration is shown in Figure B-2.

The Station File at the computer must include the following interface devices: COM Port, Hayes Modem, and then RF Path. The PS512M Power Supply and Charging Regulator supplies 5 V to

the RF95 and DC112, supplies 12 V to the P50 Radio, and acts as a null modem between the DC112 and the RF95. The RF95 and DC112 are both connected to the separate 9 pin ports on the PS512M. The RF95 Station ID at the phone-to-RF base station must be 255 to allow more than one field station to be called without terminating the initial phone link. The RF95 in the RF95-ME State recognizes Station ID 255 as a command to answer the phone and hold the ring line high which keeps the Modem Enable line high after the Ring from the Hayes has quit.

APPENDIX B. ALTERNATE BASE STATION CONFIGURATIONS

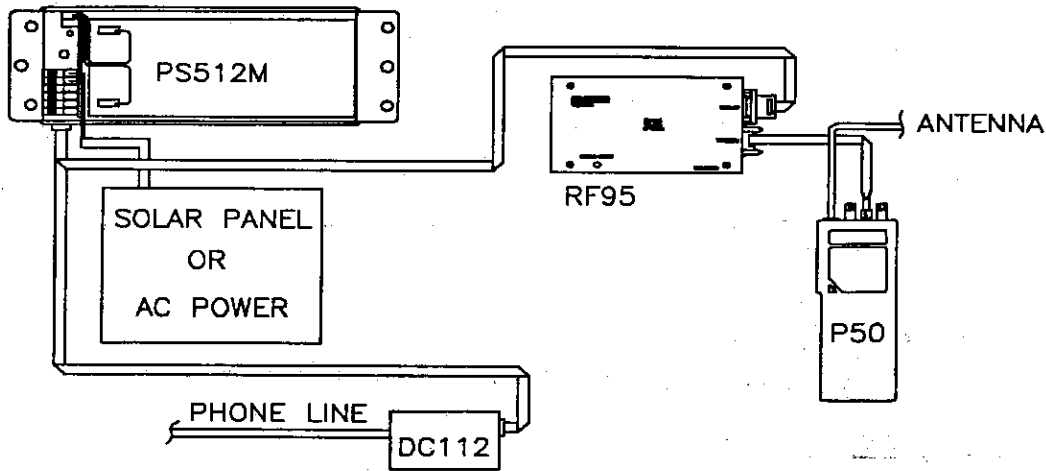

FIGURE B-2. Phone-To-RF Base Station

B.3 PHONE-TO-RF BASE STATION WITH MEASUREMENT CAPABILITY

When it is desired to have a datalogger at a phone-to-RF base station, the datalogger must be a CR10 and the RF95 must be in the RF95-SDC State. This configuration is used when the computer uses a phone modem to call the RF base station which is also being used as a field station (because measurements are being made at the station). The configuration is shown in Figure B-3.

The Station File at the computer must include the following interface devices: COM Port, Hayes Modem, and then RF Path. The DC112 Phone

Modem and the RF95 are connected to the CR10, and powered by the CR10. The RF95 Station ID at the phone-to-RF base station does not have to be 255 in this case. This is because the CR10 will automatically hold the Modem Enable line high, not being reliant on the RF95.

The datalogger at the base station should have security set. See the CR10 manual for the details of security. With security set, a password (number) is required before data can be collected. Without security, and with a CR10 at the base, data can inadvertently be collected from the base CR10 if an RF link fails during communication with another datalogger.

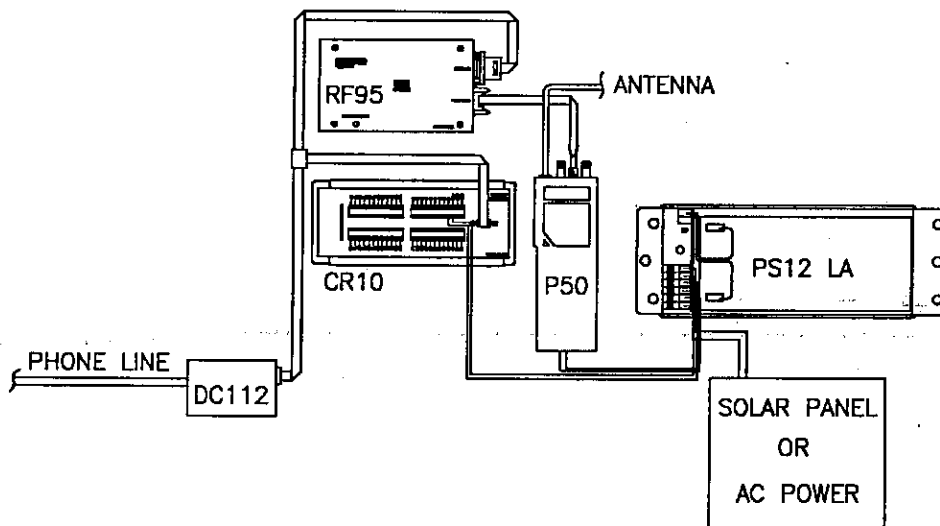

FIGURE B-3. Phone-To-RF Base with Measurement Capability

APPENDIX C. POWER CALCULATIONS

There must be enough transmission power in any RF link to complete communication. The sources of power are the radio and the antennas. Conversely, power is lost both through the cables (coax loss) and over the distance of communication (path loss). The power of the signal received (Signal Power) can be calculated as stated below.

The signal power must be greater than -95 dBm (-80 dBm @ 2.4K baud) to have a good radiotelemetry link. Decibel milliwatts (dBm) is a scale of power, 0 dBm represents one milliwatt of power. The lower limit of power for good data transmission is approximately 0.0000000000003 Watts (3X10⁻¹³), which represents -95 dBm.

Signal Power

$$SP = TP + AG - PL - CL$$

where, SP = Signal Power (dBm) Power of the signal received,
TP = Transmit Power (dBm) Rated output power of transmitting radio,
PL = Path Loss (dB) Power lost over the distance of communication (calculated below),
AG = Antenna Gain (dB) Total power gained by both the transmit and receive antennas,
and, CL = Coax Loss (dB) Total power lost through both lengths of cable connecting the transmit and receive radios to the antennas.

Path Loss

$$PL = 36.6 + 20 * \text{Log}(F) + 20 * \text{Log}(D)$$

where, PL = Path Loss,
F = Frequency (MHz),
and, D = Distance (miles).

Coaxial Cable Loss

Typical coaxial cable losses are listed below.

<u>Cable Type</u>	<u>200 MHz</u>	<u>Loss/100 ft.</u>	<u>400 MHz</u>
RG-8A/U	3.1 dB		5.0 dB
RG-58A/U	6.2 dB		9.5 dB

Transmit Power

5 Watt Radio	36.99 dBm
4 Watt Radio	36.02 dBm

Power Conversion

Conversion of Watts to dBm can be done with the following formula.

$$\text{dBm} = 10 * \text{Log}(\text{Watts}/0.001)$$

APPENDIX D. FUNDAMENTALS OF RADIOTELEMETRY

D.1 RADIO WAVES

Radiotelemetry is the process of transferring information (data) in the form of radio waves. The data is transferred on a carrier wave which normally has a sinusoidal form. Therefore, the carrier wave can be described entirely by the frequency, amplitude, and phase with respect to a reference.

The commonly used term for radiotelemetry, RF, refers to radio frequency. Which in actuality is the frequency of the carrier wave.

Radio waves can be divided into three categories: (1) ground waves, (2) direct waves, and (3) sky waves. All communication with Campbell Scientific's RF networks are done via direct waves. Direct waves travel "line-of-sight" at a maximum distance of approximately 25 miles.

Low frequency radio waves (5-10 MHz) can travel for thousands of miles using the ground wave portion of the radio wave. The ground wave is that portion of the radio wave which travels just above the surface of the ground. Conversely, the sky wave radiates to the ionosphere where a certain percentage of the energy is reflected back to earth. At the higher frequencies used for data transmission the ionosphere is penetrated by the radio wave and too small of a percentage is reflected back to earth. However, neither the ground wave or sky wave is used in Campbell Scientific's RF networks.

Energy is lost from radio waves as they travel away from the transmitting antenna. One reason for this is the loss due to dispersion of energy over a larger area; analogous to water waves reducing in size (energy) as they get farther from the source. Second is that energy is absorbed by the earth over the distance of travel. Eddy currents cut down signal power, and intervening terrain and buildings can prevent a signal from being strongly received.

The higher the frequency, the stronger the radiation field. However, at higher frequencies more energy is absorbed by the surface. The VHF and UHF frequencies can travel only a short distance between radio stations. The direct

wave, where there is no obstacles between stations, will transmit farther than any indirect waves which have been transmitted through or reflected from obstacles.

The carrier wave can be thought of as the radio wave which "carries" the data from one radio to the next. The "data" consists of an electrical signal which rides with the carrier wave. The process of placing the signal on the carrier wave is called modulation. The signal is also in the form of a wave, but usually the signal has a much lower frequency. The carrier with the modulating signal is called the modulated carrier.

The signal wave isn't used as a carrier wave because radio transmission must be of a high frequency to keep radio components small, antennas small, filtering efficient, and to isolate the radio waves from the common low frequency man-made noise.

The main forms of modulation are amplitude, frequency, and pulse modulation. Frequency modulation (FM) is used by Campbell Scientific.

D.2 ANTENNAS

An antenna is a device which captures and radiates radio waves. The antenna at the transmitting station is excited by the transmitting radio. The antenna converts energy from the radio to radiated energy. Electrons within the antenna oscillate at the frequency of the radio thereby producing radio waves. These radio waves radiate out from the antenna at the speed of light (299,800 km/s).

The transmitted radio wave will cause electrons in the receiving antenna to oscillate at the carrier frequency. The AC current thereby produced in the antenna is transferred to the radio for demodulation.

The antenna is constructed for a particular frequency, operating radius, and gain. Length, diameter, number of elements, and element spacing are among the items that can be changed to alter antenna performance at the design stage.

APPENDIX D. FUNDAMENTALS OF RADIOTELEMETRY

Every antenna has a known horizontal and vertical pattern of radiation. The horizontal radiation pattern consists of any segment of a 360 degree circle surrounding the antenna. The horizontal pattern is important to consider when a RF station is to communicate with more than one other RF station. The vertical pattern is the radiating pattern in the upward and downward directions.

Any two communicating RF stations must have a minimum level of signal power. Power is normally expressed in decibels (dB), or decibel milliwatts (dBm). Power is lost through transmission cables (transmitting and receiving) and over the communicating distance. Power is gained through the transmitting radio, and the two antennas. Antenna gain is specified in decibels in reference to a dipole, and can vary from 0 to 10 dB in common antennas. A unity gain antenna has a 0 dB gain, therefore no additional power is added by using these antennas.

Antenna gain is accomplished by either concentrating the radiating power in a small sector, or using multiple radiating elements with additive patterns.

D.3 RF95 MODEM

The RF95 Modem is the main communication control device in a radiotelemetry network. The RF95 enables a central base site to communicate with up to 254 different RF stations.

The RF95 is a microprocessor controlled device which codes all transmissions for a specific communication path. Each has a hardware ID switch for identifying different stations.

The purpose of the RF95 Modem is to control operation of the radio and provide protection for data integrity. The modem controls the communication sequences, sets data to be transferred into data blocks, creates signatures of data blocks, modulates the radio's carrier wave, and stores information on communication quality.

The user at the computer is responsible for naming the desired communication path with a setup string. This setup string contains any repeater (MOL) modem IDs and the destination

(EOL) modem ID in sequence. After sending this information out through the RF system, all of the RF95s in the specified link will set themselves in the proper mode. The RF95 has different modes to distinguish responsibilities at various localities within a link. These modes are described in Section 4.1.6 "RF95 Modem Communication Protocol".

Establishment of an RF link consists of getting all of the RF95s in the proper mode and receiving a verification block from the EOL modem.

D.4 TRANSCEIVER

The purpose of a transceiver (radio) is to transmit and receive the modulated carrier wave.

A radio is both a transmitter and receiver. The main component in the transmitter is the oscillator of which the frequency of oscillation is provided by a crystal. The crystal oscillates at a desired frequency, which is specific for the carrier frequency. The oscillator converts DC power to an AC signal. This signal is then amplified, modulated with the signal, and transmitted to the antenna system. The receiver consists of an amplifier, frequency converter to slow signal, limiter to give constant amplitude but same frequency, and discriminator or demodulator.

The radio has a known impedance, or resistance. Maximum power is transferred if the impedance of the radio matches the impedance of the antenna and cable. This impedance is generally 50 ohms. Mismatching of impedance will cause a lesser transmit power and result in a higher VSWR (Voltage Standing Wave Ratio).

When the transmission cable and antenna does not match the impedance of the output circuit of the radio, not all of the energy fed down the cable will flow into the antenna. A percentage of the energy will be reflected back forming standing waves on the cable. The ratio of voltage across the line at the high voltage points to that at the low voltage points is known as the VSWR. When the VSWR is 3.0:1 or greater, the percentage of errors per data value is greater than 50%. The VSWR should be kept below 1.5:1 for error free radiotelemetry.

APPENDIX E. RF95 STATES AND EQUIPMENT COMPATIBILITY

E.1 RF95 STATES

The RF95 Modem operates in one of two separate states. The RF95 can be utilized in either the RF95-ME (Modem Enable) State or the RF95-SDC (Synchronous Device Communication) State. The RF95-ME State is normally used for all RF networks. The RF95-SDC State must be used when there is a phone-to-RF base station with a CR10 datalogger. A switch inside the RF95 needs to be set according to the chosen state.

E.1.1 RF95-ME STATE

The RF95-ME State is always used with 21X and CR7 dataloggers, and normally with CR10 dataloggers.

RF95-ME State Description

The RF95 rings the datalogger until the datalogger raises the ME line. The CR10 waits app. 40 seconds to receive carriage returns to establish the baud rate. After the baud rate is set the CR10 transmits a carriage return, line feed, "*", and enters the Telecommunications Mode. If the carriage returns are not received within the 40 seconds, the CR10 hangs up.

When the datalogger is in the Telecommunications Mode, the ME line is high, and the RF95 is subsequently in the Transparent Mode or EOL Mode depending on the relative location of the RF95.

E.1.2 RF95-SDC STATE

The RF95-SDC State can be used to enable a CR10 to be recording measurements at a phone-to-RF base station. The SDC State is never used with 21X or CR7 dataloggers.

RF95-SDC State Description

The RF95 obeys all Synchronous Device Communication (SDC) protocol when set in the RF95-SDC State. The CR10 has the ability to address synchronous devices. The CR10 and the RF95 use a combination of the Ring (pin 3), Clock/Handshake (pin 7), and Synchronous Device Enable (SDE, pin 6) lines to establish communication. Rather than just the Modem Enable line.

When the CR10 is connected to the RF95, a 1N command is sent to the datalogger at set-up. The baud rate is set and the CR10 completes connections with the RF95. The CR10 sets the RF95 in an addressing state by raising the CLK/HS followed by or simultaneously raising the SDE line. The RF95 drops the ring line and prepares for addressing.

The CR10 then synchronously clocks 8 bits (the address) onto TXD using CLK/HS as a clock. The least significant bit is transmitted first, each bit is transmitted on the rising edge of CLK/HS. The RF95 completes addressing when the eighth bit is received.

The synchronous device capability enables the CR10 to have measurement capability at a phone-to-RF base station. A command within the address sent to the RF95 can tell the RF95 to connect to the DC112 which requires the RF95 to switch its TXD and RXD lines. Therefore all characters are routed through the DC112 to the RF95 which controls the P50 accordingly.

The RF95 then enters the Active State. The receiver is enabled when SDE and CLK/HS are high. The transmitter is enabled when SDE is high and CLK/HS is low.

In the Active State, the RF95 responds to the commands S, R, T, F, and U.

E.2 RF95/P50 vs. HT90 COMPATIBILITY

This section is an aid to customers who are currently using the older HT90/HT90-SDC/DC95/PS232 radio equipment and would now like to interface the old equipment with the new RF95/P50/RF232 equipment.

There are a few basic rules to remember when interfacing the old and new systems.

1. A RF95 is a direct replacement for a DC95 when used with a 21X or CR7.
2. The RF95 Modem will work with both the HT90 and P50 Radios.
3. The DC95 Modem will not work with the P50 Radio.

APPENDIX E. RF95 STATES AND EQUIPMENT COMPATIBILITY

4. The old PS232 Base Station will not physically hold the new RF95 Modem, and the new RF232 Base Station will not hold the old DC95 Modem.
5. The replacement for a HT90-SDC for measurement at a phone-to-RF base station is now a P50 Radio and RF95 Modem, but the CR10 must have the new software.
6. A CR10 with old software can be used with the new RF95 in the RF95-ME State, however the datalogger loses the "callback" capability as well as the SDC function.

E.3 THE "U" COMMAND

The "U" command, or Old Link command, is only needed if a DC95 with PROM 399B or 399D is being utilized at a field or repeater station when a newer DC95 PROM, or a RF95, is used at the base station.

The older model DC95 purchased before February, 1989 has a PROM which will allow

communication between radios of approximately 2400 baud rather than 3000 baud.

The DC95 PROM numbers 399B and 399D are 2400 baud, PROM 589-1 in the DC95 enables 3000 baud. The PROM number is written on the top of the PROM which is located to the left of the ID switch under the cover of the DC95.

DC95s with the 2400 baud PROMs can be used only at 2400 baud. The "U" command preceding the setup string will force communication at 2400 baud. The "S" command precedes the U command when used with the Terminal Emulator. TELCOM and TERM otherwise add the "S" command automatically. Example E-1 shows the use of the "U" command in a setup block. The default, without a "U" command, is 3000 baud. Alternatively, DC95s can be updated with PROM 589-1 to communicate at 3000 baud.

EXAMPLE E-1. Use of the "U" Command

Path: U5 10 12 7

GLOSSARY

- Antenna** - Device for radiating and receiving radio signals.
- Attenuation** - The reduction of an electrical signal without appreciable distortion.
- Base Station** - The destination for accumulated data; where data is received via radio from one or more field stations.
- Baud Rate** - A unit of data transmission speed, normally equal to one bit per second.
- Block** - Group of ones and zeroes which represent data or commands.
- BNC Connector** - A commonly used "twist type" connector on radios.
- Carrier Wave** - A radio wave upon which the signal is transmitted.
- Coaxial Cable** - An insulated RF transmission line consisting of two conductors separated by a dielectric.
- COM Port (Communication Port)** - The serial port of the computer where communication is intended.
- Decibel** - A unit of power equal to 10 times the common logarithm of the ratio of two amounts of signal power.
- End of Link Modem** - An RF modem which is at the field station.
- Field Station** - The place of origin of the data, from which the data is then transmitted by radiotelemetry.
- Forward Power** - Energy that is transmitted from a radio, through coaxial cable, and through the antenna without being reflected back to the radio.
- Line of sight** - Straight path between the transmitting and receiving antenna when unobstructed by the horizon.
- Megahertz** - Cycles per second multiplied by 1,000,000.
- Middle of Link Modem** - Any modem in an RF link which is not at the base station or the designated field station.
- Modem ID Number** - A communication identification number for an RF Modem, also an aid in specifying the RF path.
- Modulation** - Process by which one waveform (carrier) is caused to vary according to another waveform (signal).
- Omnidirectional** - Capable of operating in all directions.
- Radio** - Device which transmits and receives electrical signals by means of radio waves.
- Radio Frequency** - The number of cycles per second with which the carrier wave travels, usually specified in Megahertz.
- Radiotelemetry** - Process of transmitting data by radio communication.
- Radiotelemetry Link** - A temporary communication path within a network.
- Radiotelemetry Network** - A group of stations which communicate by radio and are used to indicate or record data.
- Reflected Power** - Energy that is transferred back into the radio after it has been transmitted by the same radio.
- Remote Site** - See Field Station.
- Repeater** - An intermediate station in an RF link used for the sole purpose of relaying data.
- RF** - An abbreviation for radio frequency, commonly used in place of radiotelemetry.
- RF Modem** - Device which modulates an electrical signal on the carrier wave, and codes all transmissions for a specific path.

GLOSSARY

RF Path - The designation of an RF link with modem ID Numbers and modem commands.

RLQA (RF Link Quality Accumulators) - Numbers which represent the quantity of communication interruptions and the level of communication noise.

Shutdown Block - Block of numbers which contain the RF Link Quality Accumulators for each modem in a terminated radiotelemetry link.

Signal Power - Power of a signal at the receiving radio, after power is lost through transmission.

Start of Link Modem - The modem located at the base station.

Squelch - Setting on the radio which specifies the minimum power level which signals must be received.

Sub Link - Any segment of an RF link which begins and ends with an RF station.

Telecommunications Mode - A datalogger status which enables communication from a computer directly to the datalogger.

UHF (Ultra High Frequency) - Carrier frequencies commonly in the range of 406 to 512 MHz.

VHF (Very High Frequency) - Carrier frequencies commonly in the range of 130 to 174 MHz.

VSWR (Voltage Standing Wave Ratio) - The ratio of the standing wave voltage across the RF transmission cable at the high voltage points to that at the low voltage points.

Unidirectional - Capable of operating only in a single direction.

INDEX

A

- Antenna, 2-1, 3-4, 4-9, D-1
 - Mounts, 4-9
 - Omnidirectional, 4-10
 - Orientation, 4-10
 - Unidirectional, 4-10
- Attenuation pads, 3-6

B

- Base Station, 1-1, 2-1, 2-6, 3-1
 - Portable, B-1
 - Phone-to-RF, B-1
 - Phone-to-RF with Measurement, B-2
- Batteries, 4-7
 - PS12 LA, 4-7
 - PS512 M, 4-8

C

- Cable, see Coaxial cable
- Charging regulators, see PS12 LA Power Supply
- CM10 Tripod, 4-11
- Computer, 2-6
- Communication port, 5-1
- Communication quality, see RLQA numbers
- Coaxial cable, 3-5, 4-10, C-1, D-2
 - Connectors, 4-10

D

- Data file, 3-3
- DC95 RF Modem, 4-1, E-1
- Distance Requirements, 1-1, 2-6, C-1, D-1
- Dual frequency applications, 5-3

E

- Enclosures, 4-13
 - 21X, 4-13
 - CR10, 4-13
 - CR7, 4-14
- Error file, 3-3

F

- Field Layout, 3-1
- Field Station, 1-1, 2-1, 3-3
 - CR10, 2-1
 - 21X, 2-3
 - CR7, 2-3

L

- Layout, see Field layout
- Lead acid battery, see Batteries
- Line-of-sight, 1-1, 2-6

M

- Modem, see RF95 Modem
- Modulation, D-1

N

- Noise, 4-5

P

- P50 Radio, 3-1, 4-6, D-2
- PC203 Power Up Control Box, 5-3
- PC208 Datalogger Support Software, 2-6, 3-2, 5-1
- Polarization, 3-1, 4-10, D-2
- Power calculations, C-1
- Power supply, 4-7
- PS12 LA Power Supply, 4-7
- PS512 M Power Supply, 4-8

R

- Radio, see P50 Radio
- Radio frequency, 1-1, 4-7, D-1
- Remote site, 1-1
- Repeater station, 1-1, 2-1, 2-6
- RF232 Base Station, 2-6, 3-1, 4-14
 - Installation, 3-1, 4-14
- RF95 Modem, 3-1, 3-5, 4-1, D-2
 - Carrier detect light, 4-2
 - Commands, 4-4
 - Data blocks, 4-5
 - Data transfer rate, 4-3
 - EOL Mode, 4-3
 - EOL modem, 4-3, 4-4
 - Local Command Mode, 4-4
 - MOL modem, 4-3
 - Repeater Mode, 4-3
 - RF95-ME State, 4-1, E-1
 - RF95-SDC State, 4-1, E-1
 - Setup block, 4-4
 - Shut down block, 4-5
 - SOL modem, 4-3
 - States, 4-1, E-1
 - Station ID, 3-1, 4-2, A-1
 - Switch settings, 4-2

Transparent Mode, 4-3
Verification block, 4-5
Wait mode, 4-3
RF cable, see Coaxial cable
RF link, 3-3, 4-3
RF modem, see RF95 Modem
RF path, 3-3, 3-5, 4-4, 5-2
RLQA numbers, 3-3, 4-5

S

Script file, 5-2
Signal power, 3-5, C-1
Solar panel, 4-8
Squelch, 3-1, 3-5, 4-6
Station file, 3-3, 5-1
Station ID, 3-1, 4-2, A-1
Sub link, 3-6

T

TELCOM, 3-2, 3-5, 5-1
TERM, 3-2, 3-4, 5-3
 Download datalogger programs, 5-3
 View real-time measurements, 5-3
 Troubleshooting, 3-4
Transformer, 4-8
Tripod, see CM10 Tripod
Troubleshooting, 3-4, 3-5, 3-6

U

UHF, 1-1

V

VHF, 1-1
VSWR, 3-6, D-2
Voltmeter, 3-5
Volume, 3-1, 4-6

W

Warranty, i
Wattmeter, 3-5