

INSTRUCTION MANUAL

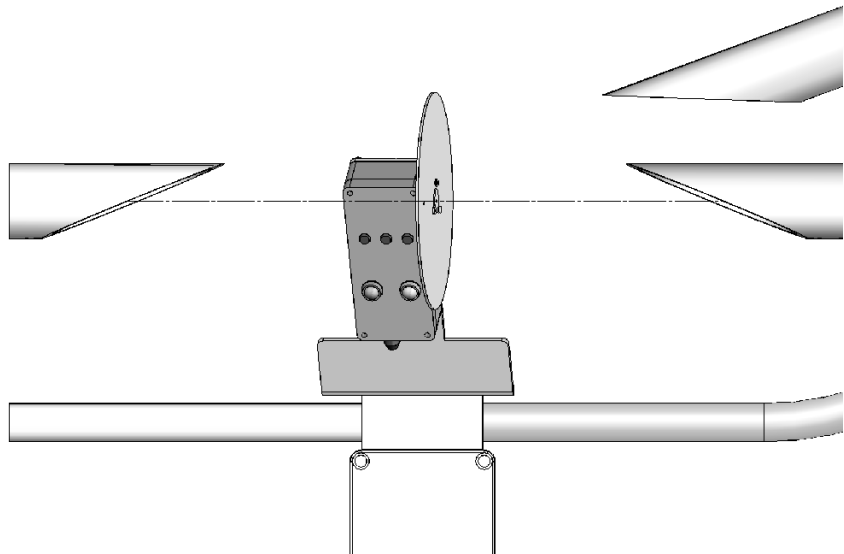

PWC100 Present Weather Sensor Calibrator

Revision: 3/12



Copyright © 2008-2012
Campbell Scientific, Inc.

Warranty

“PRODUCTS MANUFACTURED BY CAMPBELL SCIENTIFIC, INC. are warranted by Campbell Scientific, Inc. (“Campbell”) to be free from defects in materials and workmanship under normal use and service for twelve (12) months from date of shipment unless otherwise specified in the corresponding Campbell pricelist or product manual. Products not manufactured, but that are re-sold by Campbell, are warranted only to the limits extended by the original manufacturer. Batteries, fine-wire thermocouples, desiccant, and other consumables have no warranty. Campbell's obligation under this warranty is limited to repairing or replacing (at Campbell's option) defective products, which shall be the sole and exclusive remedy under this warranty. The customer shall assume all costs of removing, reinstalling, and shipping defective products to Campbell. Campbell will return such products by surface carrier prepaid within the continental United States of America. To all other locations, Campbell will return such products best way CIP (Port of Entry) INCOTERM® 2010, prepaid. This warranty shall not apply to any products which have been subjected to modification, misuse, neglect, improper service, accidents of nature, or shipping damage. This warranty is in lieu of all other warranties, expressed or implied. The warranty for installation services performed by Campbell such as programming to customer specifications, electrical connections to products manufactured by Campbell, and product specific training, is part of Campbell's product warranty. CAMPBELL EXPRESSLY DISCLAIMS AND EXCLUDES ANY IMPLIED WARRANTIES OF MERCHANTABILITY OR FITNESS FOR A PARTICULAR PURPOSE. Campbell is not liable for any special, indirect, incidental, and/or consequential damages.”

Assistance

Products may not be returned without prior authorization. The following contact information is for US and international customers residing in countries served by Campbell Scientific, Inc. directly. Affiliate companies handle repairs for customers within their territories. Please visit www.campbellsci.com to determine which Campbell Scientific company serves your country.

To obtain a Returned Materials Authorization (RMA), contact CAMPBELL SCIENTIFIC, INC., phone (435) 227-9000. After an applications engineer determines the nature of the problem, an RMA number will be issued. Please write this number clearly on the outside of the shipping container. Campbell Scientific's shipping address is:

CAMPBELL SCIENTIFIC, INC.

RMA# _____
815 West 1800 North
Logan, Utah 84321-1784

For all returns, the customer must fill out a "Statement of Product Cleanliness and Decontamination" form and comply with the requirements specified in it. The form is available from our web site at www.campbellsci.com/repair. A completed form must be either emailed to repair@campbellsci.com or faxed to (435) 227-9106. Campbell Scientific is unable to process any returns until we receive this form. If the form is not received within three days of product receipt or is incomplete, the product will be returned to the customer at the customer's expense. Campbell Scientific reserves the right to refuse service on products that were exposed to contaminants that may cause health or safety concerns for our employees.

PWC100 Table of Contents

PDF viewers: These page numbers refer to the printed version of this document. Use the PDF reader bookmarks tab for links to specific sections.

1. Introduction	1
2. Operation and Use	1
2.1 Operating Guidelines	1
2.2 Initial Configuration of the PWS100 for use of the Calibrator.....	2
3. PWS Calibration	2
3.1 Installing and Connecting up the Calibrator	3
3.2 Starting the Tests	4
4. Cleaning Guide	10
5. Calibrator Safety Guidelines	10
6. Electrical Parameters	11
6.1 PWC100 Voltages and Currents	11
6.2 Earth, 0 V and Transient Protection	11

Appendix

A. Assembly Guidelines	A-1
A.1 Assembly Guidelines	A-1
A.2 Connector Pin Outs	A-2

Figures

2-1. PWS100 calibration disk constants	2
3-1. The PWS100 enclosure showing the LEMO connector used by the calibrator	3
A-1. Attaching the velocity disk	A-1
A-2. Attaching the visibility disk.....	A-1
A-3. Attachment of the velocity calibrator	A-2

PWC100 Present Weather Sensor Calibrator

1. Introduction

The PWC100 is a customer field calibration validation device for the PWS100.

The PWC100 calibrator system simulates particle and visibility data for the PWS100 allowing verification of the calibration constants held within the system.

The following features are checked by the calibrator:

- Particle velocity
- Particle size detection
- Laser beam uniformity
- Visibility range
- Component aging

The PWC100 will give a *go/no go* indication of the PWS100 calibration to show whether the instrument is within normal operating limits. If required, the PWC100 can be used to partially recalibrate the PWS100. That method is not described in this manual. Please contact Campbell Scientific for more details or refer to the PWS100 manual.

2. Operation and Use

2.1 Operating Guidelines

Please ensure that there are no obstructions between the PWS sensor heads before the tests are started.

Ambient temperature should be $20^{\circ}\text{C} \pm 10^{\circ}\text{C}$.

The test should not be performed in the following conditions:

- Do not perform the calibration when it is raining or during any other precipitation event, such as snow, hail or drizzle.
- Do not perform the calibration when the local visibility is below approximately 10,000 meters.
- Do not perform the calibration if there is a strong wind that could blow debris into the sensing volume of the PWS.

The PWC100 is not suitable for long term outdoor use and is only designed to be exposed for the duration of the calibration test. Long term exposure to outdoor environmental conditions may cause damage to the unit.

Care must be taken not to drop or scratch either the velocity or visibility units as this may cause errors that could result in tests failing when they shouldn't.

2.2 Initial Configuration of the PWS100 for use of the Calibrator

The visibility calibration disks provided as part of the calibration kit are individually calibrated and have a number printed on them to indicate the measured signal in a reference instrument. Each PWS100 that is to be used with the calibrator has to have that value entered into its configuration so that it is referenced to the properties of that disk. Once set, the PWS100 will retain the calibrator disk information unless the sensor is reset to its factory defaults. The test procedure outlined in the rest of the manual can then be followed repeatedly without changing the settings in the sensors.

For information on how to set calibration disk constants, please refer to Section 7.4.3 of the PWS100 manual. Figure 2-1 provides the screen in which the values are shown. Please note you only need to change the constants; do not attempt to adjust the calibration of the PWS100 if carrying out the standard test procedure.

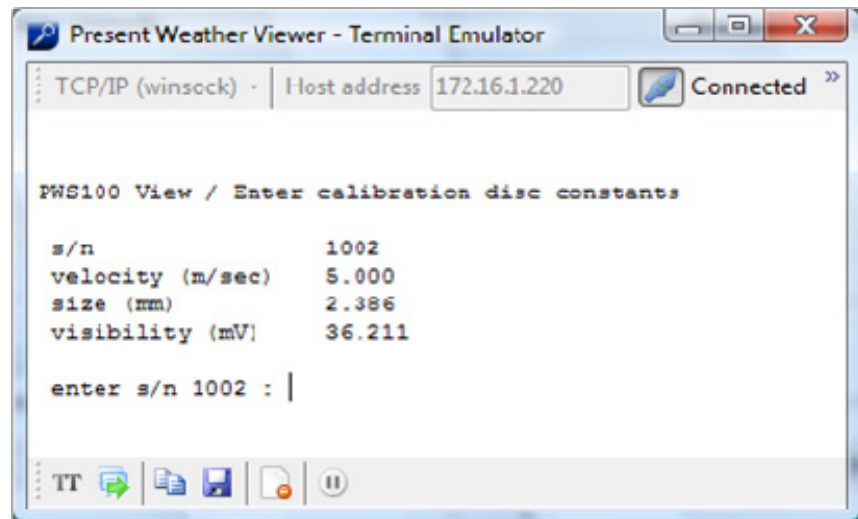

FIGURE 2-1. PWS100 calibration disk constants

For normal operation it is only necessary to set the visibility constant, as printed on the disk. It is also useful to set the calibrator serial number for reference purposes. The velocity and size constants can be left at the factory defaults of 5.000 and 2.386 as these are fixed values for a standard calibrator.

3. PWS Calibration

The calibration check procedure can be broken up into two separate sections. The first section comprises of visibility tests and the second velocity tests. If only a visibility test is required, then the tests can be finished after the first stage and the velocity tests need not be run.

It may be desirable to carry out a check of the sensor before and after cleaning the sensor's lenses to determine if the previous readings of the sensor were adversely affected by dirt. This would be at the customer's discretion.

3.1 Installing and Connecting up the Calibrator

- Remove the existing plastic blanking screws from their positions on the PWS center block.
- Fix the PWC100 visibility calibrator unit to the center position on the PWS using two of the metal countersunk fixing screws provided.

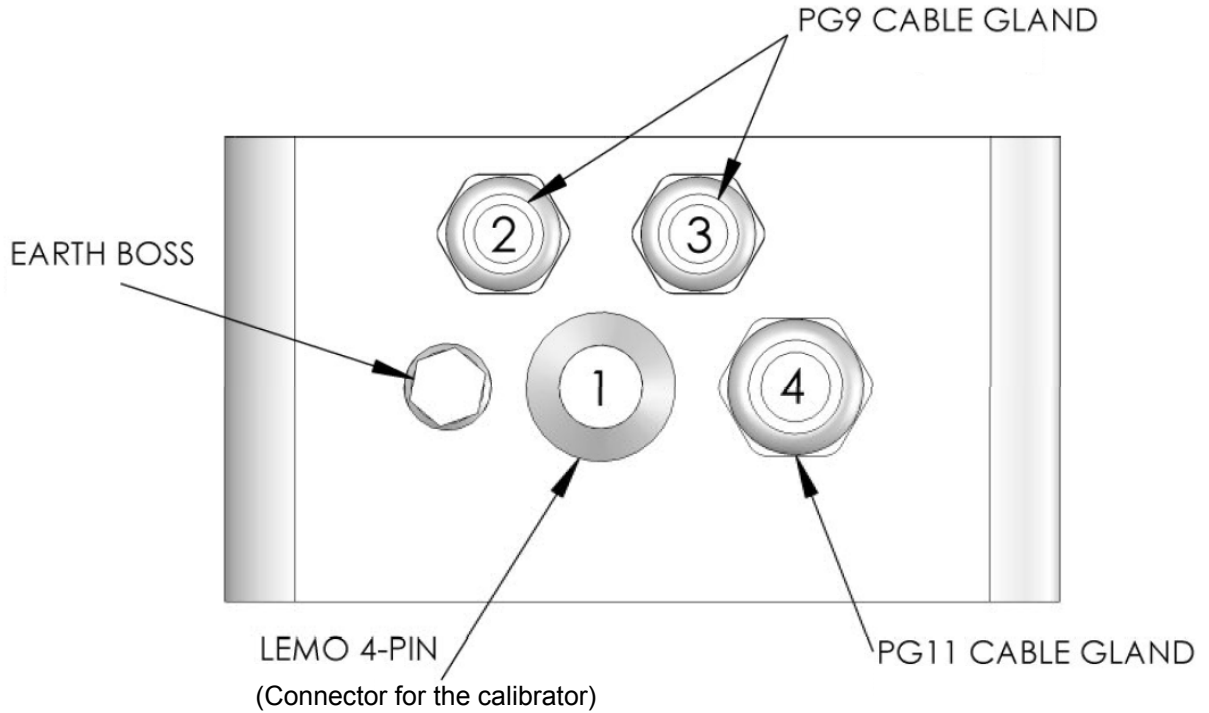

FIGURE 3-1. The PWS100 enclosure showing the LEMO connector used by the calibrator

3.2 Starting the Tests

All PWC100 tests can be performed without the need to access the PWS with a PC. Only once the tests are finished and if changes to the calibration constants are needed, will a PC be required to change the system configuration.

If at any point the LEDs behave unexpectedly, check the status table at the end of this section.

Step 1: Performing the visibility calibration

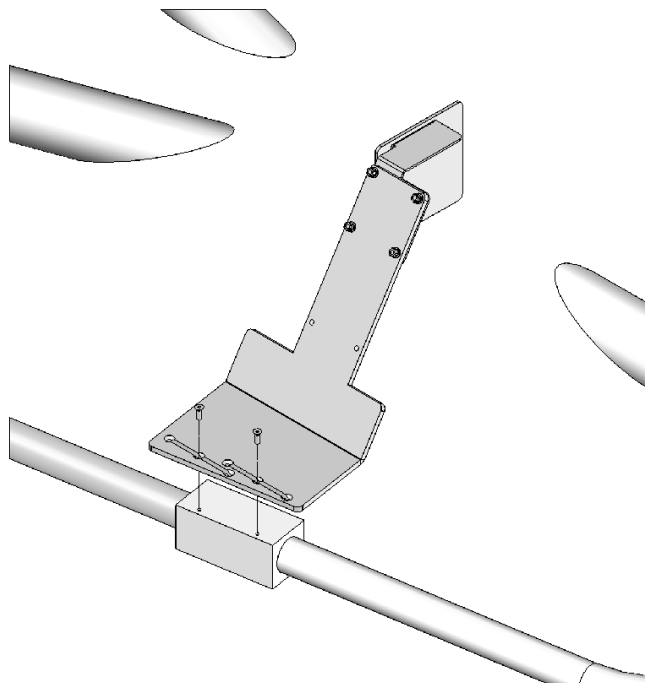

- Check that the PWC100 visibility calibrator unit is located correctly and securely (refer to Appendix A for additional details).
- Connect the LEMO connector coming from the velocity unit to the LEMO socket on the PWS (as detailed in Section 3.1). This will let the PWS know you want to start the tests. Press the *RESET/STOP* button on the PWC100. Within 10 seconds, all three LEDs should light up for approximately 3 seconds. This indicates that the calibration unit has been detected correctly by the PWS100 and that the LEDs are functioning correctly.
- LED *L* and *R* should now be flashing slowly and all other LEDs should be off.
- Once you are ready, press *START*.
- The test is now automated. LED *L* and *R* will stay illuminated until this stage of the test is complete. This test will take approximately two minutes.
- Upon successful completion of the test, LED *L* and LED *C* will be flashing slowly, indicating that the next test is ready to be started.

Step 2: Performing the visibility maximum limit check

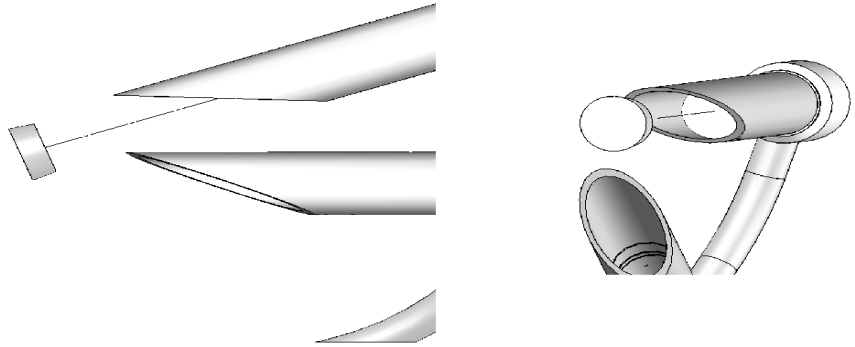

- Remove the PWC100 visibility calibration disk and place it back into its box.
- Place blanking plug into upper sensor head as shown in diagram above.
- At this point, LED *L* and LED *C* should be flashing slowly.
- Once you are ready, press *START*.
- LED *L* and LED *C* will be illuminated for the duration of the test. This test will take approximately two minutes.
- Upon successful completion of the test, LED *C* will be flashing slowly. This indicates the end of the visibility test.
- Remember to remove the blanking plug from the PWS before continuing. ***(This is important!)***

At this point, steps three through five can be ignored if only the visibility calibrations are required.

To view the visibility test results alone, press the *RESET/DONE* button. This will jump the unit to the end of the tests and will display the results in the normal way detailed at the end of the calibration section (this is the only stage in the tests where pressing the *RESET/DONE* button will not restart the tests).

Please remember to read the final section relating to tidying up and ensuring all screws and fasteners are returned to their original positions.

Step 3: Position 1: Center position

Attaching the velocity calibration unit

- Fix the PWC100 velocity calibrator unit to the center position on the PWS using two of the countersunk fixing screws provided

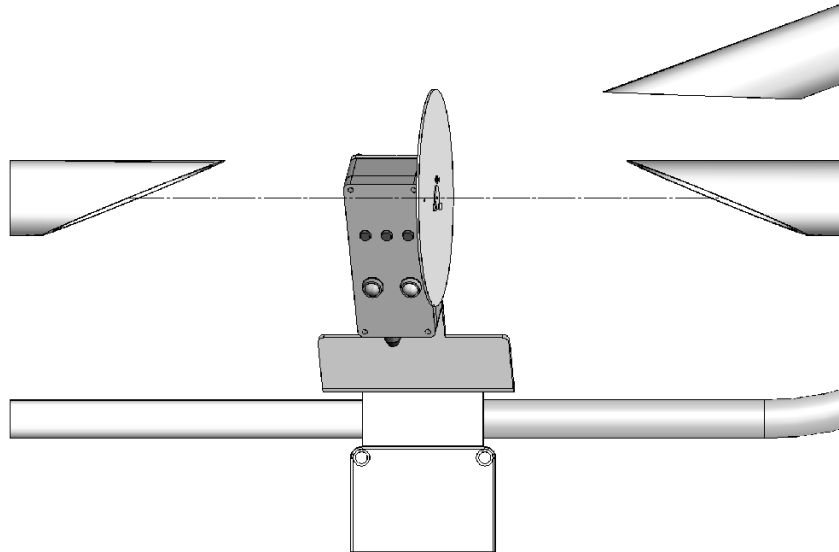

- Check that the velocity calibrator is located correctly and securely.
- LED *C* should now be flashing slowly and all other LEDs should be off.
- Once you are ready, press *START*.
- The test is now automated and the disk should start rotating. LED *C* will stay illuminated until this stage of the test is complete.
- Wait for the calibration disk to stop rotating. This test will take approximately two and a half minutes.
- Upon successful completion of the test, LED *L* will be flashing slowly and LED *C* will be turned off.

Step 4: Position 2: Left

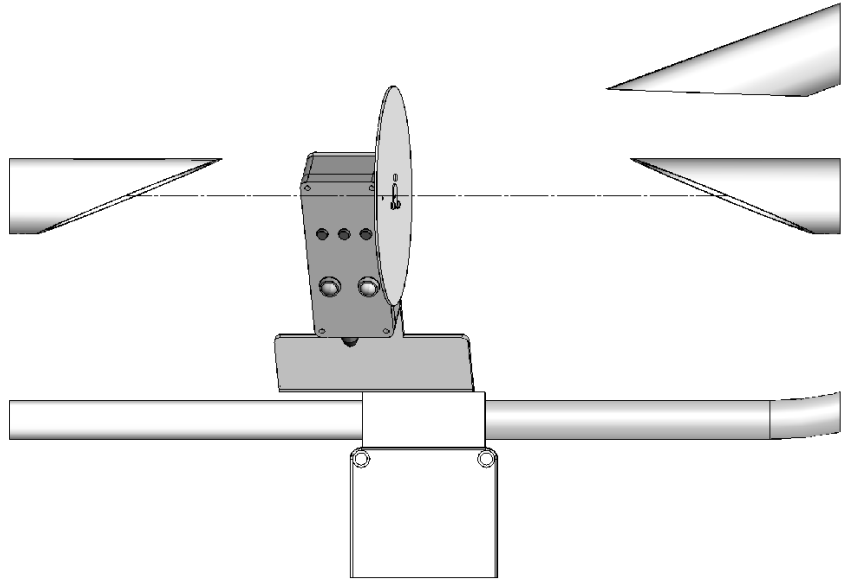

- Move the calibrator into the left hand position by unscrewing the calibrator mounting screws slightly and sliding the calibrator fully to the left. Then retighten the screws once in position.
- Visually check that the calibrator is located correctly and securely.
- LED *L* should now be flashing slowly and all other LEDs should be off.
- Once you are ready, press *START*.
- The test is now automated and the disk should start rotating. LED *L* will stay illuminated until this stage of the test is complete.
- Wait for the calibration disk to stop rotating. This test will take approximately two and a half minutes.
- Upon successful completion of the test, LED *R* will be flashing slowly and LED *L* will be turned off.

Step 5: Position 3: Right

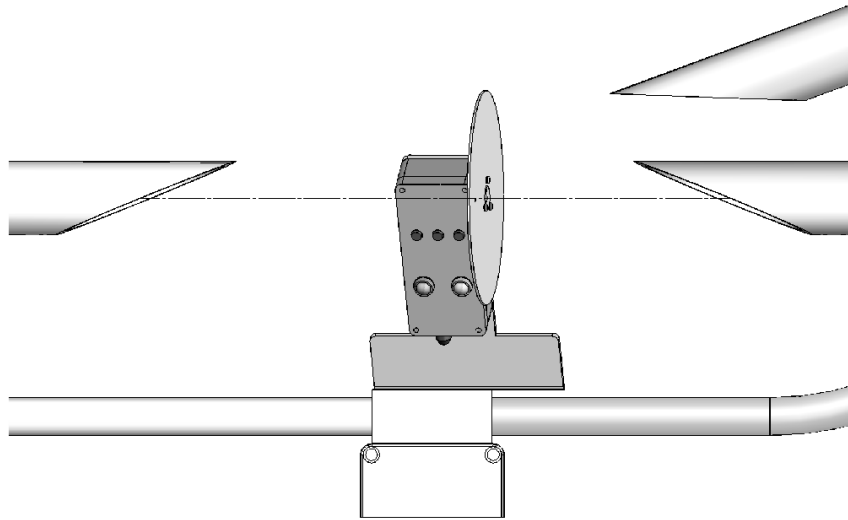

- Move the calibrator into the right-hand position by unscrewing the calibrator mounting screws slightly and sliding the calibrator fully to the right. Then retighten the screws once in position.
- Visually check that the calibrator is located correctly and securely.
- LED *R* should now be flashing slowly and all other LEDs should be off.
- Once you are ready, press *START*.
- The test is now automated and the disk should start rotating. LED *R* will stay illuminated until this stage of the test is complete.
- Wait for the calibration disk to stop rotating. This test will take approximately two and a half minutes.

Final calibration results

The calibration verification has now been completed. All three of the LEDs should be solidly illuminated indicating that the PWS100 is still within its calibration limits.

If all three LEDs are flashing, then the calibration was found to be outside of desired levels and further action needs to be taken.

If any of the calibration checks have failed (all three light flashing after test), then the tests should be re-run after ensuring the disk is clean and the area between the heads is clear of any obstructions. This should remove any chance that the calibrator or another external factor was the cause.

If the PWC100 still indicates a problem, please contact Campbell Scientific for further advice.

Step 6: Final stage

- Remember to reinstall the plastic blanking screws back into the PWS100 before leaving the site.
- If a CS215-PWS or other piece of equipment was unplugged in order to perform the tests, then ensure it is reconnected.
- Remember to check that the blanking plug has not been left in the PWS.
- Place all calibration equipment carefully back into its correct box being careful not to scratch the visibility disk.

Final calibration result table

Result/ LED Status	LED L	LED C	LED R	Description
Test passed	ON	ON	ON	If all tests have passed, all the LEDs will be illuminated at the same time
Calibration required	Flashing	Flashing	Flashing	Calibration values are suspect. Do not use the calibration values created from this test

Fault states during tests

If during the calibration cycle, LED C and R start flashing together, then there has been an error either with the communications to the PWS100 or that the disk has stalled or is unable to attain the required speed for calibration.

State	LED L	LED C	LED R	Description
Disk stalled	-	Flashing	Flashing	PWS calibrator problem

Quick look LED status table

Test state	Ready/complete state			Running state		
	Left	Center	Right	Left	Center	Right
Visibility test	Flash		Flash	ON		ON
Visibility maximum range test	Flash	Flash		ON	ON	
Velocity test position 1 (Center)		Flash			ON	
Velocity test position 2 (Left)	Flash			ON		
Velocity test position 3 (Right)			Flash			ON
Final result states						
Calibration passed	ON	ON	ON			
Calibration required	Flash	Flash	Flash			
Error conditions						
Fault occurrence during tests		Flash	Flash			

4. Cleaning Guide

It is important to ensure that the visibility and velocity disks are clean prior to use. Finger prints and small quantities of dust should not impair performance significantly, but it is highly recommended that the disks are kept clean and care is taken to ensure the surfaces are not scratched, cracked or damaged. A cleaning agent that does not leave a residue such as isopropyl alcohol or a product specifically designed to clean optical equipment should be used along with a lint free cloth.

5. Calibrator Safety Guidelines

During the velocity tests, the calibration disk will be rotated at a moderate speed.

It is recommended that the user visually checks the disk for any cracks or distortions on its surface. If the disk is cracked or distorted in any way, the tests should not be performed as this may cause an incorrect result or even damage to the calibration unit. Campbell Scientific should be contacted for advice about any damage that may have occurred to the disk.

When performing the tests, the operator should stand more than two meters from the calibrator. This prevents the operator from interfering with the results by causing reflections, and keeps the operator away from the rotating disk.

It is also recommended that the operator stands behind the laser hood while the PWS is active.

6. Electrical Parameters

6.1 PWC100 Voltages and Currents

	Nominal	Max	Notes
General details			
Standby current	29 mA	30 mA	No tests running
Operating current	125 mA	150 mA	Disk rotating at test speed
Spin up current	500 mA	700 mA	Disk spinning up to speed
+ Volts	+12 V	+2 8V	Main supply voltage

6.2 Earth, 0 V and Transient Protection

The user must ensure that the ground lug on the PWS is connected to the earth lug on the logger or another suitable termination point. The PWC100 is connected to this earth via the umbilical cable. This connection acts as the discharge path for electrical transients such as static and surge. Failure to correctly terminate this connection could lead to damage to the unit or faulty operation.

The PWC100 is protected against external electrostatic discharges from user contact but not lightning related surges caused by nearby strikes. Therefore, do not leave the PWC100 connected to the PWS100 for prolonged periods in field conditions.

Appendix A. Assembly Guidelines

A.1 Assembly Guidelines

The PWC100 visibility and velocity calibration disks can easily be removed for cleaning or repair if needed.

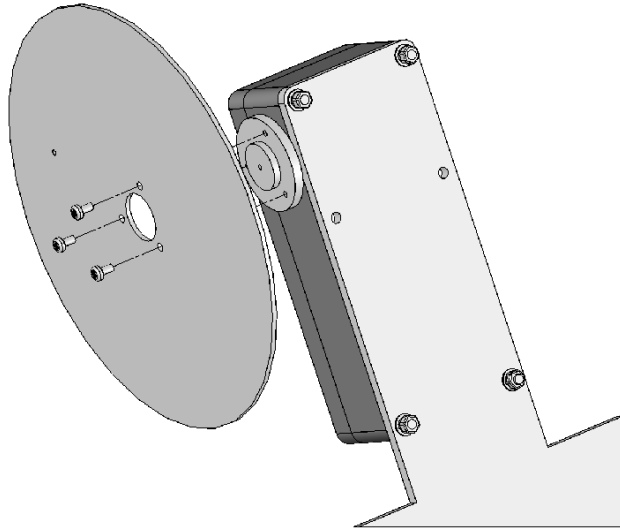

FIGURE A-1. Attaching the velocity disk

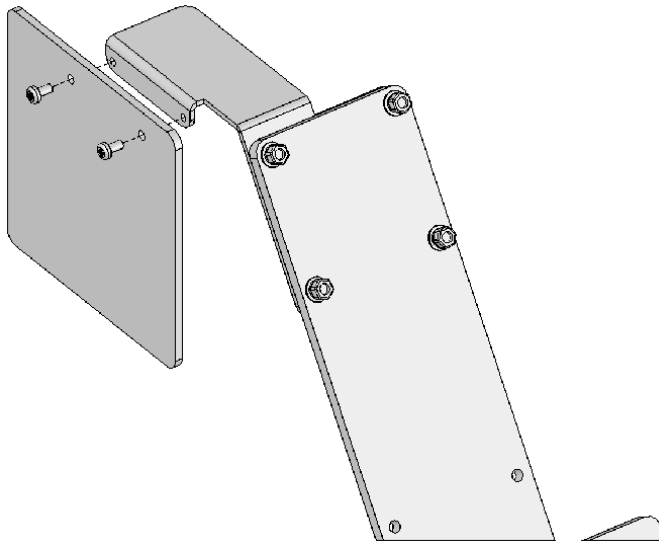

FIGURE A-2. Attaching the visibility disk

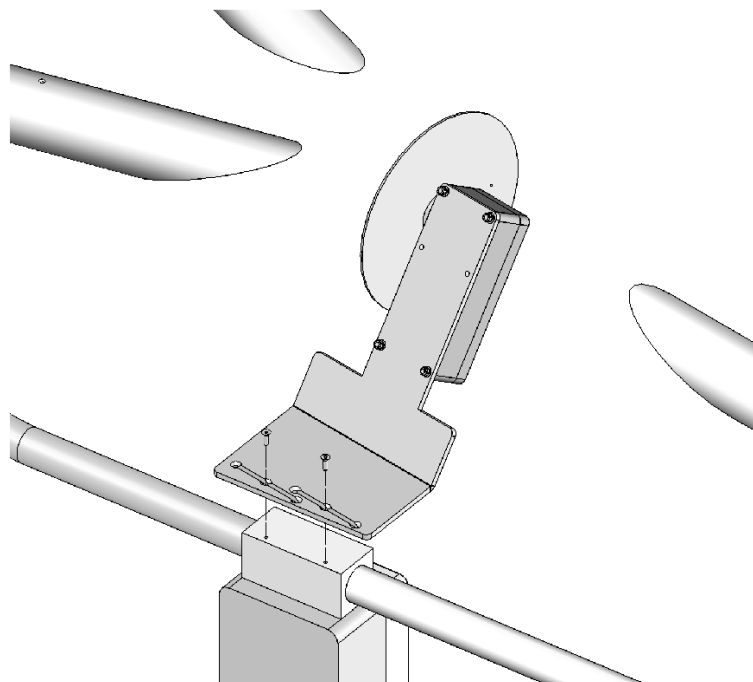
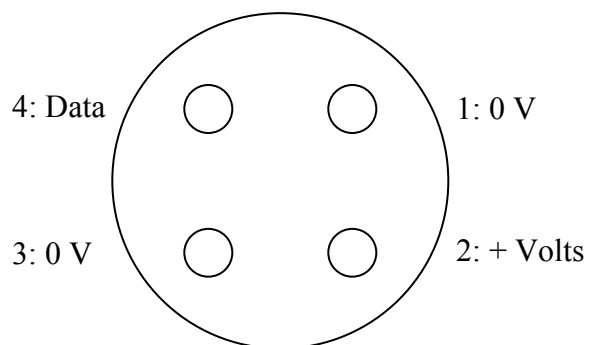

FIGURE A-3. Attachment of the velocity calibrator

A.2 Connector Pin Outs

Connector Front View



Campbell Scientific Companies

Campbell Scientific, Inc. (CSI)

815 West 1800 North
Logan, Utah 84321
UNITED STATES
www.campbellsci.com • info@campbellsci.com

Campbell Scientific Africa Pty. Ltd. (CSAf)

PO Box 2450
Somerset West 7129
SOUTH AFRICA
www.csafrica.co.za • cleroux@csafrica.co.za

Campbell Scientific Australia Pty. Ltd. (CSA)

PO Box 8108
Garbutt Post Shop QLD 4814
AUSTRALIA
www.campbellsci.com.au • info@campbellsci.com.au

Campbell Scientific do Brazil Ltda. (CSB)

Rua Luisa Crapsi Orsi, 15 Butantã
CEP: 005543-000 São Paulo SP BRAZIL
www.campbellsci.com.br • suporte@campbellsci.com.br

Campbell Scientific Canada Corp. (CSC)

11564 - 149th Street NW
Edmonton, Alberta T5M 1W7
CANADA
www.campbellsci.ca • dataloggers@campbellsci.ca

Campbell Scientific Centro Caribe S.A. (CSCC)

300 N Cementerio, Edificio Breller
Santo Domingo, Heredia 40305
COSTA RICA
www.campbellsci.cc • info@campbellsci.cc

Campbell Scientific Ltd. (CSL)

Campbell Park
80 Hathern Road
Shepshed, Loughborough LE12 9GX
UNITED KINGDOM
www.campbellsci.co.uk • sales@campbellsci.co.uk

Campbell Scientific Ltd. (France)

3 Avenue de la Division Leclerc
92160 ANTONY
FRANCE
www.campbellsci.fr • info@campbellsci.fr

Campbell Scientific Spain, S. L.

Avda. Pompeu Fabra 7-9, local 1
08024 Barcelona
SPAIN
www.campbellsci.es • info@campbellsci.es

Please visit www.campbellsci.com to obtain contact information for your local US or International representative.