

Net Radiometer

Model Q7.1

The Q7.1 is an high-output thermopile sensor that generates a millivolt signal proportional to the net radiation level. The sensor is mounted in a glass-reinforced plastic frame with a built-in level. A ball joint is supplied on the stem to facilitate leveling. The sensor surface and surrounding surfaces are painted flat black to reduce reflections within the instrument and to achieve uniform performance over reflective and non-reflective surfaces.

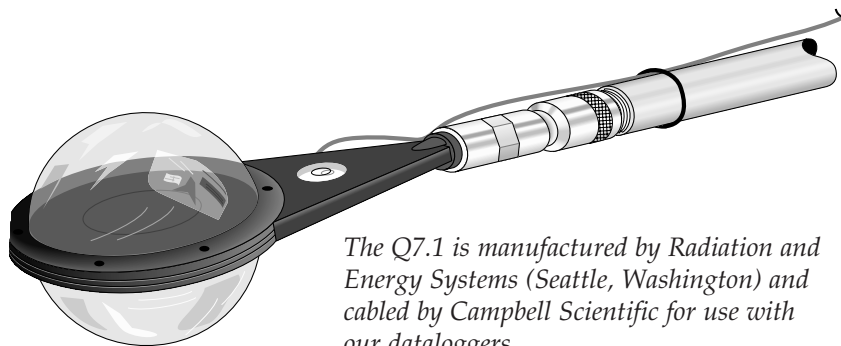

The Q7.1 is manufactured by Radiation and Energy Systems (Seattle, Washington) and cabled by Campbell Scientific for use with our dataloggers.

Sensor surfaces are protected from excessive convective cooling by hemispherical polyethylene windshields. Polyethylene is used for the windshield material because it is transparent to both long and shortwave energy. The windshields are open to the atmosphere through a desiccated breather tube to prevent the domes from collapsing at night. A mounting stake located away from the tower to decrease shading and interference is recommended. Net radiation measurement height is typically between 1 and 3 m.

Features

- 60-junction thermopile with low electrical resistance (4 Ω nominal) to reduce noise susceptibility
- Top and bottom surfaces painted flat black and protected from convective cooling by hemispherical heavy-duty polyethylene windshields (0.25 mm thick)
- Windshields do not require pressurization
- O-ring seals for easy windshield replacement
- Desiccant contained in support arm (volume 45 cm³) breather port on end of support arm
- No power required

Ordering Information

Q7.1-L	REBS Net radiometer with user-specified lead length (enter lead length in feet after L)
-SM	CM210 Crossarm-to-Pole Bracket
5730	Q7.1 Replacement Domes (pair)

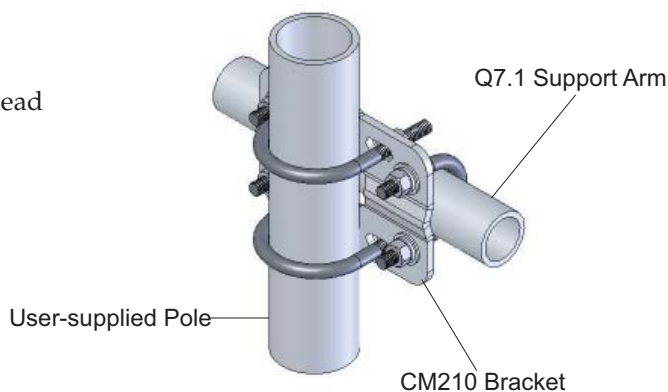

The Q7.1 is attached to a pole using the CM210 Crossarm-to-Pole Bracket. The bracket is created during manufacture to allow pipes of varying diameters to seat snugly into the bracket.



CAMPBELL SCIENTIFIC, INC.

815 W. 1800 N. • Logan, Utah 84321-1784 • (435) 753-2342 • FAX (435) 750-9540 • www.campbellsci.com

Specifications

- Nominal calibration factors:
9.6 W m⁻² mV⁻¹ for positive values
11.9 W m⁻² mV⁻¹ for negative values
- Uncorrected wind effect:
up to 6% reduction @ 7 m s⁻¹ for positive fluxes
up to 1% reduction @ 7 m s⁻¹ for negative fluxes
- Spectral response: 0.25 to 60 μm
- Time constant: Approximately 30 seconds
- Size of sensing head: 2.3" x 2.8" x 7.0" (5.7 x 7.2 x 17.7 cm)
- Support arm dimensions: 0.8" (2.0 cm) diameter, 29.5" (75.0 cm) length
- Weight: 4.1 lbs (1.86 kg)



CAMPBELL SCIENTIFIC, INC.

815 W. 1800 N. • Logan, Utah 84321-1784 • (435) 753-2342 • FAX (435) 750-9540
Offices also located in: Australia • Brazil • Canada • England • France • South Africa

Copyright © 1998, 2005
Campbell Scientific, Inc.
Printed September 2005