

Solar Radiation Sensor

Model SP-LITE

The SP-LITE is a rugged pyranometer manufactured by Kipp & Zonen. It measures incoming global solar irradiance using a silicon photovoltaic detector mounted in a cosine-corrected diffuser. The diffuser houses a shunt resistor that converts the signal from μA to mV allowing the SP-LITE to be measured directly by a Campbell Scientific datalogger. The SP-LITE is calibrated for the daylight spectral range of 400 to 1100 nm and therefore should not be used under vegetation or artificial lights.

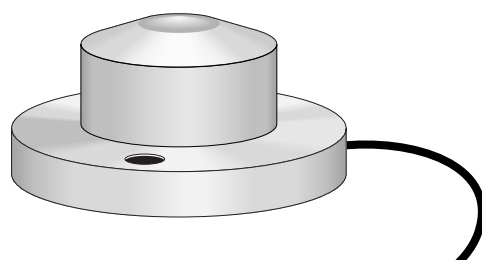

Mounting

To ensure accurate measurements, the SP-LITE should be leveled using a 14282 leveling fixture, which incorporates a bubble level and three adjusting screws. The 14282 leveling fixture mounts to a tripod or tower using the CM225 mount. For most applications, Campbell Scientific recommends attaching the CM225 to a CM202, CM204, or CM206 crossarm. The CM225 can also be attached to a tripod or tower mast.

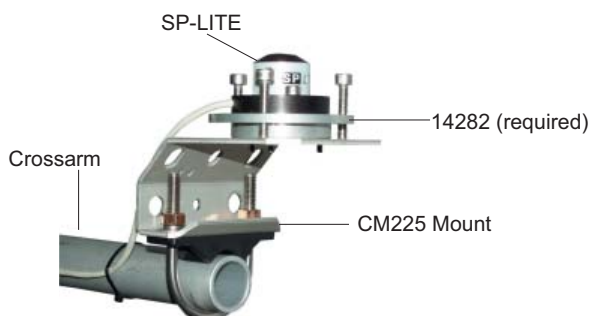

To attach the CM225 to a horizontal crossarm, place the u-bolt in the holes on the bottom of the bracket (shown). To attach the CM225 to a vertical mast or pole, place the u-bolt in the holes in the side of the bracket.

Ordering Information

SP-LITE-L Pyranometer with user-specified lead length. Specify the lead length in feet after the -L. The standard lead length provided with the sensor is 16' (SP-LITE-L16). A 24' or 34' length is suggested for mounting the sensor to the top of the UT20 or UT30 towers, respectively (recommended only where shading at lower heights is a problem).

14282 Leveling Fixture includes mounting and leveling screws.

17906 CM225 Mount for attaching the 14282 and sensor to a crossarm or mast.



CAMPBELL SCIENTIFIC, INC.

815 W. 1800 N. • Logan, Utah 84321-1784 • (435) 753-2342 • FAX (435) 750-9540 • www.campbellsci.com

Specifications

Light Spectrum Waveband:	400 to 1100 nm
Sensitivity:	10 $\mu\text{V W}^{-1} \text{m}^2$
Response Time:	<1 second
Temperature Dependence:	$\pm 0.15\% / ^\circ\text{C}$
Temperature Range:	-30° to 70°C
Directional Error:	<10% up to 80°
Dimensions:	2.2" (55 mm) diameter 1.3" (34 mm) height
Weight:	6.4 oz. (181 g), 12.8 oz. (362 g) with 14282
Datalogger Requirements:	One differential or single-ended analog channel
CE Compliance:	CE compliant under the European Union's EMC Directive



CAMPBELL SCIENTIFIC, INC.

815 W. 1800 N. • Logan, Utah 84321-1784 • (435) 753-2342 • FAX (435) 750-9540
Offices also located in: Australia • Brazil • Canada • England • France • South Africa • Spain

Copyright © 2001, 2005
Campbell Scientific, Inc.
Printed June 2005