

Distance Sensor

Model SR50

The SR50 is a rugged, acoustic distance sensor that is manufactured by Campbell Scientific Canada. It measures the elapsed time between emission and return of an ultrasonic pulse. This measurement can be used to determine snow or water depth. An air temperature measurement is required to correct for variations of the speed of sound in air.

The SR50 was designed to meet the stringent requirements of measuring depths and uses a multiple echo processing algorithm to help ensure measurement reliability. The SR50 is compatible with our CR200-series, CR510, CR10(X), CR1000, CR3000, CR7, and CR5000 dataloggers. SDI-12 and pulse train output options are available for measuring the SR50.

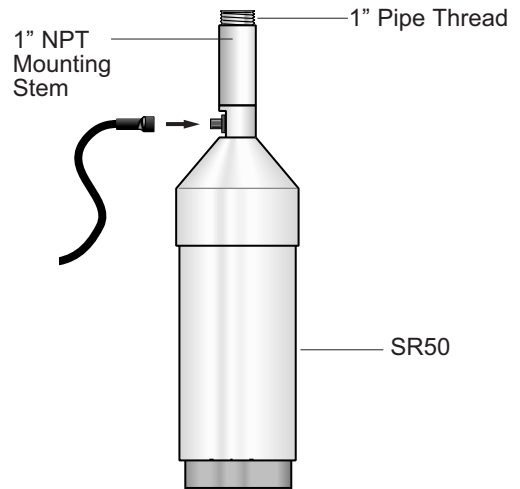

Mounting

The SR50 needs to be mounted so that its beam is perpendicular to the surface and not obstructed. Typically this can be accomplished by mounting the SR50 to a CM206 6' Crossarm or user-supplied pole via a NU-RAIL fitting or CM220 Mount. The crossarm or pole is attached to a tripod mast, tower leg, or user-supplied pole via the CM210 bracket (included with the CM206). If the surface is at an angle the CM206 Crossarm or pole can be attached to the tripod mast, tower, or pole via the CM230 Adjustable Inclination Mount.

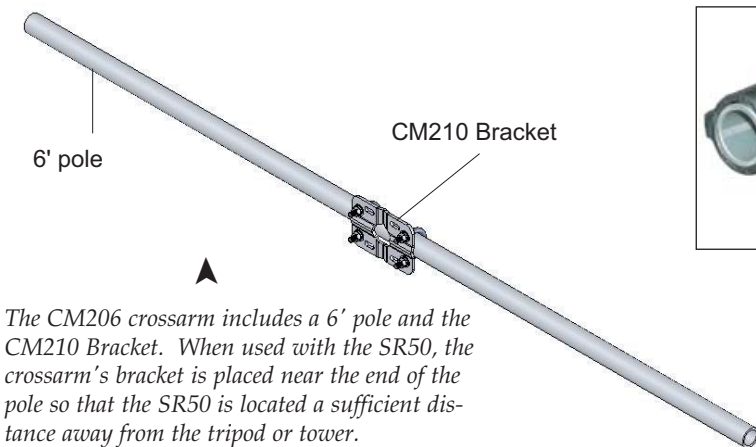

The CM206 crossarm includes a 6' pole and the CM210 Bracket. When used with the SR50, the crossarm's bracket is placed near the end of the pole so that the SR50 is located a sufficient distance away from the tripod or tower.



The SR50 attaches to the CM206 or a user-supplied pole via the NU-RAIL fitting (at left) or CM220 Bracket (bottom).

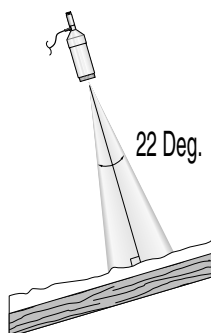

CM230 Mount

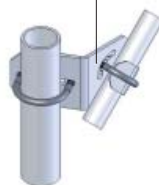

If the surface is at an angle (far left), the CM230 Adjustable Inclination Mount is used to position the SR50 so that it is perpendicular to the ground.



CAMPBELL SCIENTIFIC, INC.

815 W. 1800 N. • Logan, Utah 84321-1784 • (435) 753-2342 • FAX (435) 750-9540 • www.campbellsci.com

Ordering Information

SR50-L	Distance sensor with user-specified lead length. Specify the lead length, in feet, after the L. For example, an SR50-L10 orders an SR50 with a 10 foot lead length.
-CM	1' x 1" NU-RAIL Fitting
-SM	CM220 Right Angle Mounting Kit (attaches sensor to crossarm)
-AM	CM230 Adjustable Inclination Mount
CM206	Crossarm with mounting bracket, 6 ft (2 m) long

Specifications

Power Requirements: 9 to 16 Vdc, typically powered
by the datalogger's 12 Vdc power supply.

Power Consumption: 2 mA quiescent
250 mA measurement peak

Measurement Time: 0.6 seconds typical
3.0 seconds max

Output Options (selected by configuring internal jumpers):
SDI-12, Pulse train, or Serial ASCII

Measurement Range: 1.6 to 32.8 ft (0.5 to 10 m)

Beam Acceptance: Approx. 22°

Accuracy: ±0.4" (1 cm) or 0.4% of distance to target
whichever is greatest

Operational Accuracy: 1" typical

Resolution: 0.004" (0.1 mm)

Operating Temperature: -45° to +50°C

Maximum Cable Length: 200 ft (60 m) for SDI-12 output;
984 ft (300 m) for pulse train output

Dimensions: length 12.2" (31 cm)
diameter 3" (7.5 cm)

Weight: 2.9 lbs (1.3 kg)



CAMPBELL SCIENTIFIC, INC.

815 West 1800 North • Logan, Utah 84321-1784 • (435) 753-2342 • Fax (435) 750-9540
Offices also located in: Australia • Brazil • Canada • England • France • Germany • South Africa • Spain

Copyright © 1990, 2006
Campbell Scientific, Inc.
Printed February 2006