

# INSTRUCTION MANUAL



## ***Geonor T-200B - Series***

### ***Precipitation Gauges***

600mm, 1000mm, and 1500mm capacity options

**March 2016**



Copyright © 2011 - 2016  
•Campbell Scientific (Canada) Corp.



## WARRANTY AND ASSISTANCE

This equipment is warranted by CAMPBELL SCIENTIFIC (CANADA) CORP. ("CSC") to be free from defects in materials and workmanship under normal use and service for **twelve (12) months** from date of shipment unless specified otherwise. \*\*\*\* **Batteries are not warranted.** \*\*\*\* CSC's obligation under this warranty is limited to repairing or replacing (at CSC's option) defective products. The customer shall assume all costs of removing, reinstalling, and shipping defective products to CSC. CSC will return such products by surface carrier prepaid. This warranty shall not apply to any CSC products which have been subjected to modification, misuse, neglect, accidents of nature, or shipping damage. This warranty is in lieu of all other warranties, expressed or implied, including warranties of merchantability or fitness for a particular purpose. CSC is not liable for special, indirect, incidental, or consequential damages.

Products may not be returned without prior authorization. To obtain a Return Merchandise Authorization (RMA), contact CAMPBELL SCIENTIFIC (CANADA) CORP., at (780) 454-2505. An RMA number will be issued in order to facilitate Repair Personnel in identifying an instrument upon arrival. Please write this number clearly on the outside of the shipping container. Include description of symptoms and all pertinent details.

CAMPBELL SCIENTIFIC (CANADA) CORP. does not accept collect calls.

Non-warranty products returned for repair should be accompanied by a purchase order to cover repair costs.



Campbell Scientific (Canada) Corp.  
14532 131 Avenue NW | Edmonton AB T5L 4X4  
780.454.2505 | fax 780.454.2655 | [campbellsci.ca](http://campbellsci.ca)

# Table of Contents

---

PDF viewers: These page numbers refer to the printed version of this document. Use the PDF reader bookmarks tab for links to specific sections.

<b>1.</b>	<b>Introduction .....</b>	<b>1</b>
<b>2.</b>	<b>Cautionary Statements.....</b>	<b>1</b>
<b>3.</b>	<b>Initial Inspection .....</b>	<b>1</b>
<b>4.</b>	<b>Overview .....</b>	<b>2</b>
<b>5.</b>	<b>Specifications .....</b>	<b>3</b>
	5.1 T-200B-series Precipitation Sensors .....	3
<b>6.</b>	<b>Installation .....</b>	<b>4</b>
	6.1 Siting .....	4
	6.2 Mounting .....	4
	6.3 Attaching Pedestal to Foundation.....	6
	6.3.1 Concrete Foundation.....	6
	6.3.2 Rock Foundation.....	7
	6.4 Mounting the Pedestal .....	7
	6.5 Precipitation Sensor Installation.....	8
	6.5.1 Remove Gauge Cover.....	8
	6.5.2 Placing Sensor on the Pedestal .....	8
	6.5.3 Inserting Mounting Bolts .....	9
	6.5.4 Install Sensor(s) and Support Chains .....	9
	6.5.5 Install Container in Support Dish .....	9
	6.5.6 Antifreeze Requirements .....	10
	6.5.7 Oil to Eliminate Evaporation .....	11
	6.5.8 Setscrew .....	11
	6.5.9 Replace Sensor Cover.....	11
	6.6 Alter Wind Screen Installation .....	11
<b>7.</b>	<b>Operation .....</b>	<b>17</b>
	7.1 Wiring.....	17
	7.1.1 Connecting Sensor to Transient Arrestor on Bucket Support Rim.....	17
	7.1.2 Connecting Wires from Transient Arrestor to Sensor Interface ..	17
	7.1.3 For Period Average Measurement .....	18
	7.1.4 For Pulse Count Measurement.....	18
	7.2 Connecting the Datalogger or Manual Read-out Unit .....	19
	7.3 Programming .....	19
	7.3.1 T-200B 1 Sensor – Period Average Measurement Example.....	20
	7.3.2 T-200B 3 Sensor – Period Average Measurement Example.....	21
	7.3.3 T-200B Pulse Count Measurement Example.....	24

<b>8.</b>	<b>Troubleshooting and Maintenance.....</b>	<b>26</b>
8.1	Tools .....	26
8.2	Service Interval .....	26
8.2.1	Cleaning the Container.....	27
8.3	Checking Sensor Function .....	27
8.3.1	Empty Bucket Check .....	27
8.3.2	Full Bucket Check.....	28
8.4	Removing and Replacing the Transducer .....	28
8.5	Rust Protection Maintenance .....	29
<b>Appendix A.</b>	<b>Alter Wind Screen Diagrams.....</b>	<b>30</b>
A.1	Precipitation Gauge Wind Shield Assembly .....	30
A.2	Precipitation Gauge Wind Shield Segment .....	30
A.3	Alter Wind Screen Blade .....	31
A.4	Precipitation Gauge Pedestal.....	31

## **Figures**

FIGURE 6—1. Cross-section of T-200B Precipitation Gauge .....	5
FIGURE 6—2. A) T-200B with 1.2 m diameter Alter wind screen, mounted to pedestal . B) T-200B with 2.4 m Alter wind screen. ....	6
FIGURE 6—3. 600 mm x 600 mm foundation block showing 4 anchor bolts, with a 225 mm distance between bolts.....	7
FIGURE 6—4. At least 375 mm anchor bolts penetrating foundation block .....	7
FIGURE 6—5. Orientation of mounting holes on pedestal .....	8
FIGURE 6—6. Gauge cover. Close-up of clamp.....	8
FIGURE 6—7. Sensor frame on pedestal with proper orientation.....	9
FIGURE 6—8. Geonor inner and outer Alter wind screen with pedestal .....	12
FIGURE 6—9. T-200B Precipitation Gauge with 1 m pedestal and 1.2 m Alter wind screen .....	16
FIGURE 8—1. Removing the Alter wind screen from 3 of four posts.....	27

## **Tables**

TABLE 6-1. Antifreeze Solution Propylene glycol (40%) / Methanol (60%) .....	10
TABLE 7-1. Transducer / 455020 Transient Arrestor (on bucket support rim).....	17
TABLE 7-2. 455020 Transient Arrestor / 455060 Signal Interface (in datalogger enclosure) .....	18
TABLE 7-3. 455060 Signal Interface/Datalogger .....	18
TABLE 7-4. 455060 Signal Interface/Datalogger .....	18



# ***T-200B-series Precipitation Gauges***

---

## **1. Introduction**

The T-200B-series precipitation gauges are designed for year round, automatic precipitation measurements. Sensors are available in 600 mm, 1000 mm, and 1500 mm capacities. Vibrating wire transducers (sensors) are used to measure total precipitation and rate of precipitation. Each capacity of gauge is able to use 1 or 3 sensors. Using more than one sensor ensures redundancy in data collection. Precipitation can be reported at real-time intensity to any interval required. The precipitation sensor is simple to configure for use with automatic data acquisition units.

Because of its simplicity and low power requirement, the T-200B is well suited for remote locations where power may only be available from solar energy. The T-200B requires a pedestal, wind screen, and conductor interface cables, which are available separately.

The T-200B was developed in Norway and has a long-standing history of operation. There are more than 2000 systems installed worldwide, with applications in national weather services, climatic research institutes, hydro power companies, airport authorities, road authorities, agricultural services, avalanche prediction centres, and winter sport resorts.

T-200B-series precipitation sensors are manufactured by Geonor, and cabled by Campbell Scientific.

Before using the T-200B please study:

- Section 2, Cautionary Statements
- Section 7.5, Wiring

More details are available in the remaining sections.

## **2. Cautionary Statements**

- Although the T-200B is designed to be a rugged and reliable device for field use, care should be taken when handling or moving it to avoid damage.
- There are no user-serviceable parts and any attempt to disassemble the device will void the warranty.

## **3. Initial Inspection**

- Upon receipt of the T-200B, inspect the packaging and contents for damage. File any damage claims with the shipping company. Immediately check package contents against the shipping documentation. Contact Campbell Scientific about any discrepancies.

- The model number and cable length are printed on a label at the connection end of the cable. Check this information against the shipping documents to ensure the expected product and cable length are received.
- The T-200B is shipped with the 455060 signal interface(s), 455020 transient arrestor(s), level, siphon pump, vibrating wire sensor(s), support chains, screws, and outer housing.
- Calibration Certificate.

## 4. Overview

The sensor has a protective housing with a WMO standard 200 cm<sup>2</sup> inlet. Inside the inlet is a container for collecting precipitation. The amount of precipitation is measured by using vibrating wire load sensors.

The collection container is suspended from three points, each supporting 1/3 of the weight. The use of the three sensor configuration ensures the continuation of data recording even if one of the sensors fails. It also ensures that the total amount of precipitation is measured even if there is a deviation from the horizontal plane.

Precipitation collected in the container is weighed with a vibrating wire load sensor, which gives a frequency output. The frequency will be a function of the applied tension on the wire. From this, the amount of precipitation can be computed. The frequency is recorded as a square-shaped 0-5 V signal. This signal can easily be transmitted and interfaced to most data acquisition systems. There are no mechanical moving parts, eliminating other possible sources of error.

The sensor collection containers have a maximum capacity of:

- 600 mm = 12 L
- 1000 mm = 20 L
- 1500 mm = 30 L

Antifreeze topped by a thin layer of low viscosity oil must be added to the container to melt solid precipitation and impede evaporation. No electrical heating is required, thus eliminating a common source of error.

The T-200B must be mounted to a pedestal. We recommend either the galvanized steel 1m or 2.5 m Geonor pedestal. The choice of pedestal will depend on the expected snow pack at the site.

Using the 1 m pedestal and having the foundation flush with the ground, the inlet of the T200B will be as follows:

- 600 mm capacity - 1.75 m above ground
- 1000 mm capacity - 1.75 m above ground
- 1500 mm capacity - 2.05 m above ground

Additionally, an Alter wind screen is required. We recommend the 470200 Geonor 1.2 m (4') diameter Alter wind screen. It is mounted around the precipitation sensor to minimize the effect of wind on the precipitation

measurement. The 470220 Geonor 2.4 m diameter (8') Alter wind screen is available if extra protection is required.

The gauge and the 470200 Alter wind screen are mounted to the pedestal. The 470220 Alter wind screen attaches to the 470200 and requires additional footings to secure vertical members.

Conductor Interface Cables are required to connect the instrument to the datalogger, transient arrestors, and signal interfaces.

- **3 Sensor Configuration**

The FIN6COND-L (Campbell Scientific) connects the gauge (transient arrestors) to the 455060 signal interface.

2 wires from the FIN6COND-L (Campbell Scientific) to a transient arrestor and the 455060 signal interface.

3 x FIN4COND-L (Campbell Scientific) are required; one for each 455060 signal interface connection to the datalogger.

- **1 Sensor Configuration**

The FIN2COND-L (Campbell Scientific) connects the gauge (transient arrestors) to the 455060 signal interface.

A FIN4COND-L (Campbell Scientific) is required to connect the 455060 signal interface to the datalogger.

## 5. Specifications

### 5.1 T-200B-series Precipitation Sensors

<b>Capacity:</b>	600 mm 1000 mm 1500 mm
<b>Collection Area:</b>	200 cm <sup>2</sup>
<b>Sensitivity:</b>	0.05 mm (600 mm) 0.075 mm (1000 mm) 0.1 mm (1500 mm)
<b>Accuracy:</b>	0.1% full scale
<b>Repeatability:</b>	0.1 mm (600 mm) 0.1 mm (1000 mm) 0.15 mm (1500 mm)
<b>Power Draw:</b>	3.4 mA per vibrating wire 6-7 mA on warm-up
<b>Operating Range:</b>	-40° to +60°C

<b>Temperature Drift:</b>	0.001%FS/°C
<b>Materials:</b>	Aluminum alloy
<b>Dimensions:</b>	Ø = 390 mm; H = 760 mm (600 mm) Ø = 390 mm; H = 800 mm (1000 mm) Ø = 390 mm; H = 1000 mm (1500 mm)
<b>Mounting:</b>	Universal 3-point with leveling system incorporated in base
<b>Maximum Cable Length:</b> 1 km	
<b>Compatibility</b>	
<b>Dataloggers:</b>	CR200(X) series CR800 series CR1000 CR3000 CR5000 CR510 CR10(X) CR23X

## 6. Installation

### Note

---

Ensure you have your Calibration Certificate prior to setup

---

It is always recommended to pre-configure and test the system before taking it to the field. Issues that are unresolved before placing instrumentation in the field will usually be more difficult to resolve.

### 6.1 Siting

#### Note

---

The T-200B must be kept above the snow pack

---

The T-200B should be mounted in a relatively level spot, representative of the surrounding area. For accurate measurements, the T-200B sensor must be sheltered from the wind with an Alter wind screen, and above the snow pack. A minimum of 45° from the top of the inlet must be clear of obstructions.

The pedestal can be installed in rock, soil, or attached to a structure. The pedestal must be rigid to prevent movement and vibration, which can be caused by frost heave, loosening of the soil, or wind.

### 6.2 Mounting

We recommend the T-200B be mounted on a galvanized steel 1 m or 2.5 m Geonor pedestal, depending on the depth of the snow pack. The foundation must be at least 0.6 m x 0.6 m (2' x 2') for the 1.2 m (4') diameter Alter wind screen. A larger sized foundation is required for the 2.4 m (8') Alter wind screen. The depth of either foundation must meet local building code requirements.

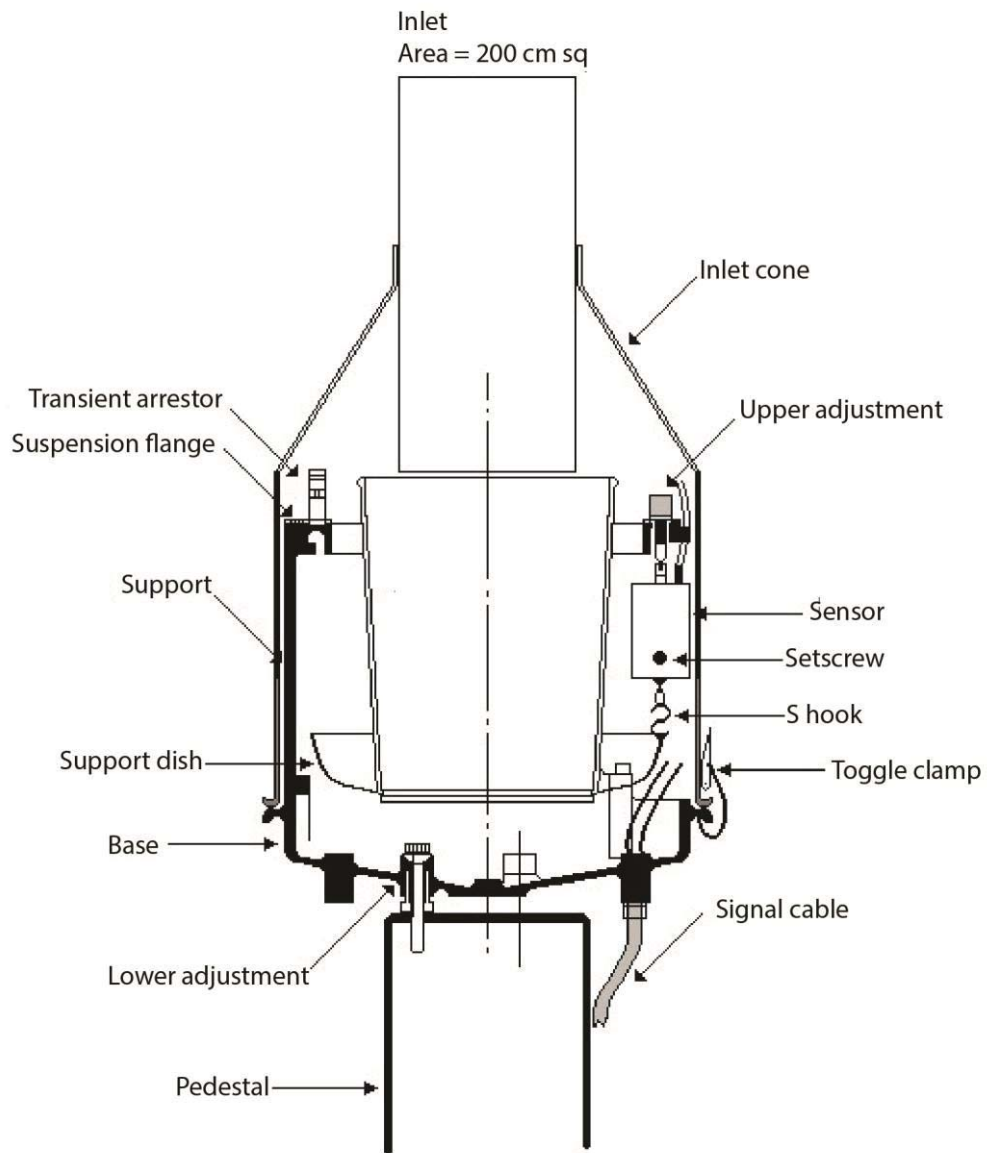

FIGURE 6—1. Cross-section of T-200B Precipitation Gauge

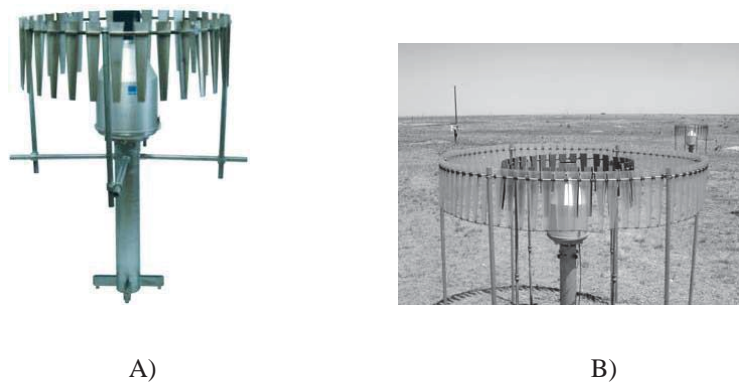

FIGURE 6—2. A) T-200B with 1.2 m diameter Alter wind screen, mounted to pedestal. B) T-200B with 2.4 m Alter wind screen.

## 6.3 Attaching Pedestal to Foundation

### 6.3.1 Concrete Foundation

**Note**

---

A stable pedestal is required for accurate data. Any movement of the sensor will affect data

---

The concrete foundation block must remain steady; movement of the sensor may lead to errors in the data. The size and depth of the foundation depend mostly on the frost depth and strength of soil. Be sure to excavate deep enough to avoid frost heave or dynamic forces caused by wind, etc. As a general guideline, excavate 600 to 1000 mm, but refer to local building code to determine best practice. The height of the foundation can extend from flush with the ground to any required height.

The foundation must be at least 600 mm x 600 mm to support the 4' diameter Alter wind screen, and larger for the 8' diameter Alter wind screen. See Figure 6-3.

The 4 anchor bolts must be set vertically, and should be oriented in north-south, and east-west directions, with a 225 mm distance between bolts. Use a wooden template of the foundation block to assist positioning the anchor bolts (see Figure 6-3).

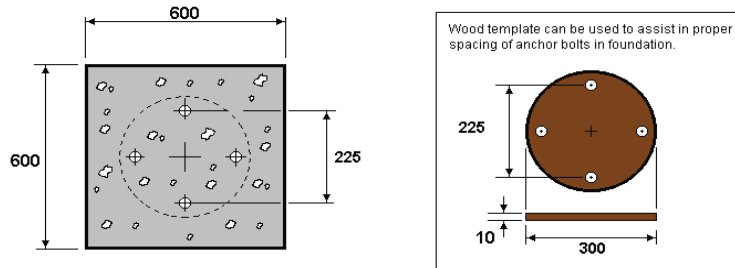

FIGURE 6—3. 600 mm x 600 mm foundation block showing 4 anchor bolts, with a 225 mm distance between bolts.

### 6.3.2 Rock Foundation

On a rock surface, drill holes for anchor bolts. Grout the anchor bolts in place at a minimum depth of 200 mm. Make sure there is a sufficient thread (at least 150 mm) to mount the pedestal and clamping nuts.

Anchor bolts should be 20 mm (3/4") or 7/8" diameter galvanized or stainless steel threaded anchor bolts with a minimum length of 375 mm. Be sure to leave at least 150 mm of exposed thread above the foundation surface.

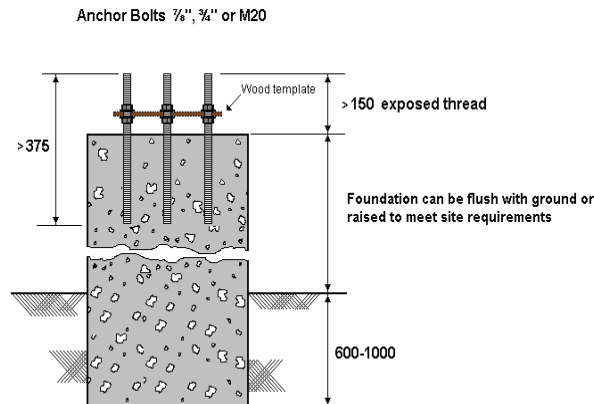

FIGURE 6—4. At least 375 mm anchor bolts penetrating foundation block

### 6.4 Mounting the Pedestal

Mount the reaction nut, lock washer, washer on the anchor bolt, approximately 25 mm (1") above the surface. Do not let the pedestal rest on the base. Using the level, adjust the level of the 4 nuts.

When mounting the pedestal, make sure the mounting holes for the sensor form a triangle pointed south (see Figure 6-5). Level the pedestal, and install upper washers, lock washers, and nuts on anchor bolts. Tighten and check that the pedestal is rigid and level. Make adjustments as necessary.



FIGURE 6—5. Orientation of mounting holes on pedestal

## 6.5 Precipitation Sensor Installation

### 6.5.1 Remove Gauge Cover

Remove cover by releasing the 3 clamps at the base, and lift the cover straight up to clear the frame.



FIGURE 6—6. Gauge cover. Close-up of clamp

### 6.5.2 Placing Sensor on the Pedestal

Align support holes at the base of the sensor with the mounting holes on top of the pedestal. This places one sensor at the northern point.



FIGURE 6—7. Sensor frame on pedestal with proper orientation

### 6.5.3 Inserting Mounting Bolts

Insert the M8 bolts through the black washers into the support holes in the base and screw into pedestal. Do not tighten bolts; the bolts must be loose to allow for levelling the sensor. Level the sensor by adjusting the levelling screw found under the sensor. Once the sensor is level, tighten the 3 mounting bolts.

### 6.5.4 Install Sensor(s) and Support Chains

---

**Note** The sensor has a setscrew on the side to protect it. Loosen or remove the screw for the sensor to work

---

For the one sensor configuration, install the sensor at the northern support point. Install support chains in the other two support points. For the three sensor configurations, install the sensors and record their location. Make sure the wires from the sensors are on the same side as the hole in the rim.

Connect S-hooks at the bottom of the sensors and chains to support the dish through the pre-drilled holes. Level the support dish by turning the black knurl nuts on the sensors and chains.

### 6.5.5 Install Container in Support Dish

---

**Note** The support dish must be free to swing in all directions. Resistance will contribute to errors

---

Carefully place the container in the support dish, ensuring it fits tightly. To ensure similar installation when the container is removed and replaced, mark the support point locations on the container. Make sure the container is level, by using the level provided. Black knurl nuts can be adjusted accordingly.

### 6.5.6 Antifreeze Requirements

To keep collected precipitation in a liquid state, an antifreeze blend must be used. If the precipitation freezes, sublimation may occur and the container may be damaged.

The capacity of the collected precipitation decreases when antifreeze is added; the antifreeze becomes part of the total volume collected. A blend of propylene glycol and methanol (40/60) is recommended. This blend is used to make the density of the antifreeze similar to water, in order to prevent stratification, which leads to the formation of ice. Table 6-1 shows the amount of antifreeze needed to keep the collected precipitation from freezing at various temperatures.

<b>TABLE 6-1. Antifreeze Solution                      Propylene glycol (40%) / Methanol (60%)</b>		
<b>Antifreeze as % total capacity</b>	<b>Freezing Point (°F)</b>	<b>Freezing Point (°C)</b>
0	32	0
10	26	-3
20	20	-7
30	10	-12
36	0	-18
40	-5	-20
43	-10	-23
48	-20	-29
52	-30	-34
55	-40	-40
58	-50	-46
60	-60	-51

### 6.5.7 Oil to Eliminate Evaporation

---

**Note** To eliminate evaporation, it is essential to use oil

---

Add 0.4 L low viscosity oil to the bucket (all sizes). We recommend Low Pour Hydraulic Oil. Oil must not become viscous in anticipated temperature ranges. We recommend changing oil at least once a year to prevent deterioration, which can result in the evaporation of collected precipitation.

### 6.5.8 Setscrew

---

**Note** We recommend keeping the setscrew in place until assembly/maintenance is complete

---

The transducer setscrew can be loosened or removed. When loosening the setscrew, unscrew at least 4 revolutions to keep it clear of the vibrating wire. Be sure to secure the setscrew if left in place.

### 6.5.9 Replace Sensor Cover

Replace sensor cover and snap the 3 clamps into place.

## 6.6 Alter Wind Screen Installation

---

**Note** Install the Alter wind screen so that the blades are approximately 13 mm above the T-200B inlet

---

Tools required for installation of the Alter wind screen

- Level
- Pipe wrench
- Allen key (supplied)

A wind screen is required to prevent the undesirable effects of wind turbulence around the gauge.

The Geonor pedestal (1 m or 2.5 m) has wind screen mounts. Using the Geonor Alter wind screen ensures proper installation at the specified 13 mm above the sensor inlet.

If using the 2.4 m (8') diameter Alter wind screen, cement foundations need to be installed (see Figure 6-8, below). We suggest installing the pedestal first. Use the horizontal sections with the Kee-Klump to hold 4 of the vertical posts in place while the cement cures. Do not forget to slide the inner Kee-Klump on the horizontal section first.

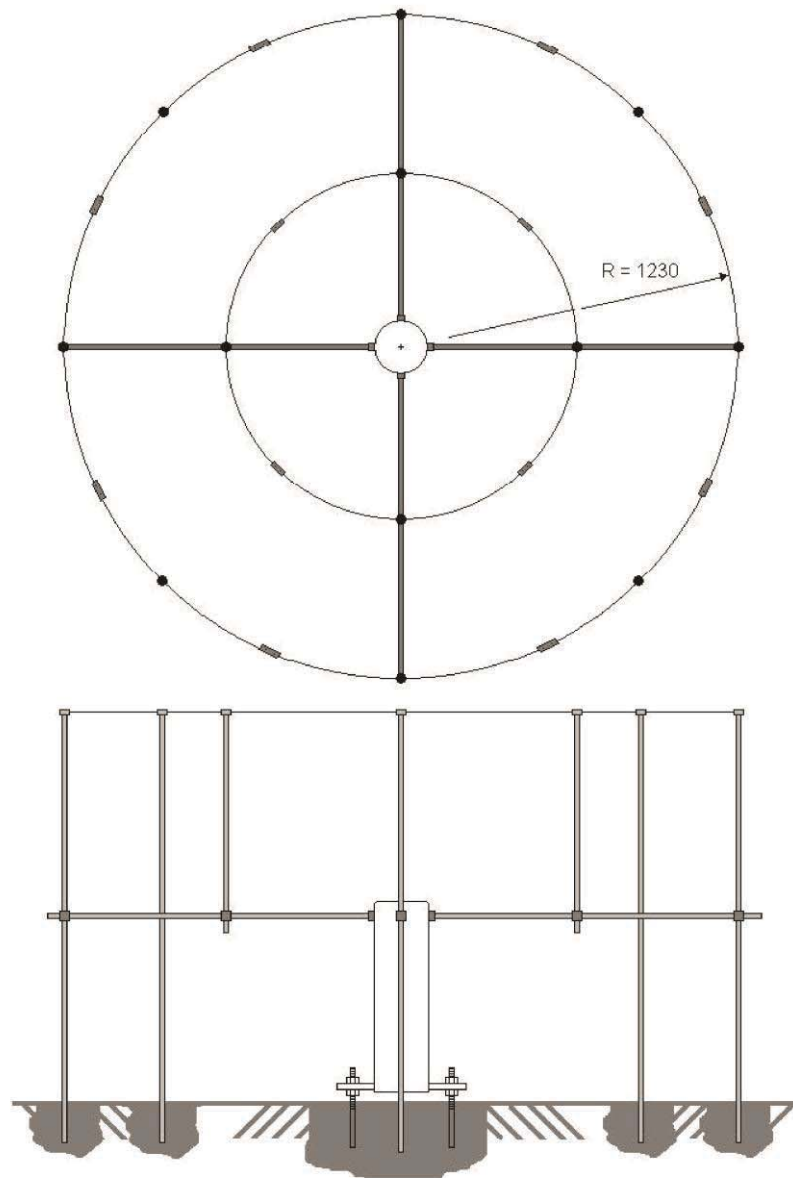
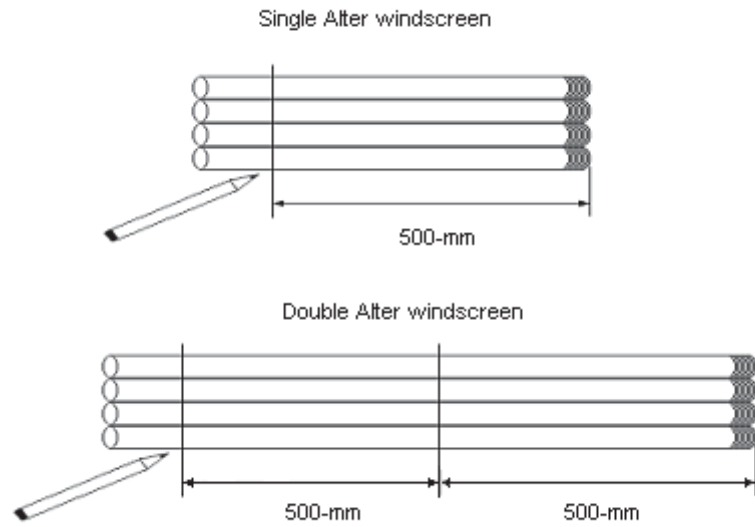

FIGURE 6—8. Geonor inner and outer Alter wind screen with pedestal

Use the following steps to install Alter wind screens:

1. Make a mark 500 mm from the threaded end on the horizontal pipes for the single Alter wind screen (1.2 m or 4' diameter), and 1000 mm for the outer Alter wind screen (2.4 m or 8' diameter).



2. Mount the connectors for the ring segment on the vertical sections of the pipe. To indicate the level of the Kee-Klamp, mark 817 mm below the connector by wrapping tape around the pipe several times. The connectors for the outer Alter wind screen can be mounted later.

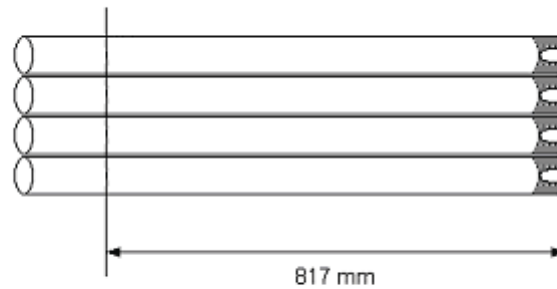

3. Insert horizontal tubes into the threaded fittings on the pedestal. Tighten with pipe wrench.

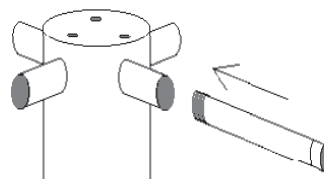

4. Slide the Kee-Klamps on so that the inside edge lines up with the 500 mm mark, and 1000 mm mark where applicable.



5. Align the clamps vertically. Tighten the nut with the Allen key supplied. Adjustments will be made later.

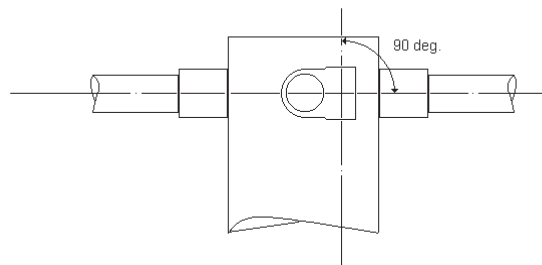

6. Insert vertical pipes for the 1.2 m (4') diameter Alter wind screen in Kee-Klamp with connector for ring at top. The tape will rest on the Kee-Klamp.

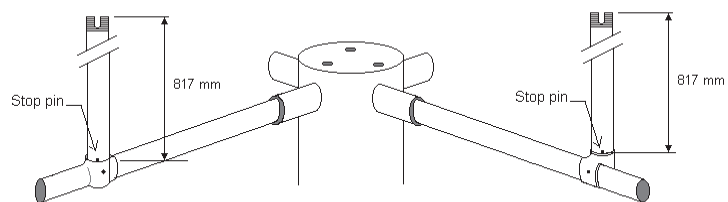

7. Lay ring segments of the 1.2 m (4') diameter Alter wind screen out. Attach ring connector to the end of each segment. Slide the blades and spacers on, in the order shown below. Keep the channels of the blades facing outward. Connect the segment to make a complete circle.

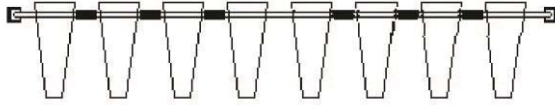

8. Place the ring in the slots on the vertical pipes.

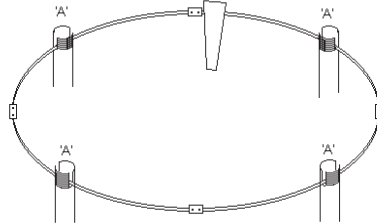

9. Install PVC caps to hold ring firmly in place.



10. Make adjustments

11. Arrange the 8 ring segments for the 2.4 m (8' diameter) Alter wind screen and follow steps to install blades, spacers, and ring connector (like in Step 7).

12. With 3 or more people, the 8 segments needed to form the complete circle can be connected, and put into place. If not, connect 4 segments to make a half circle, and connect the two halves.

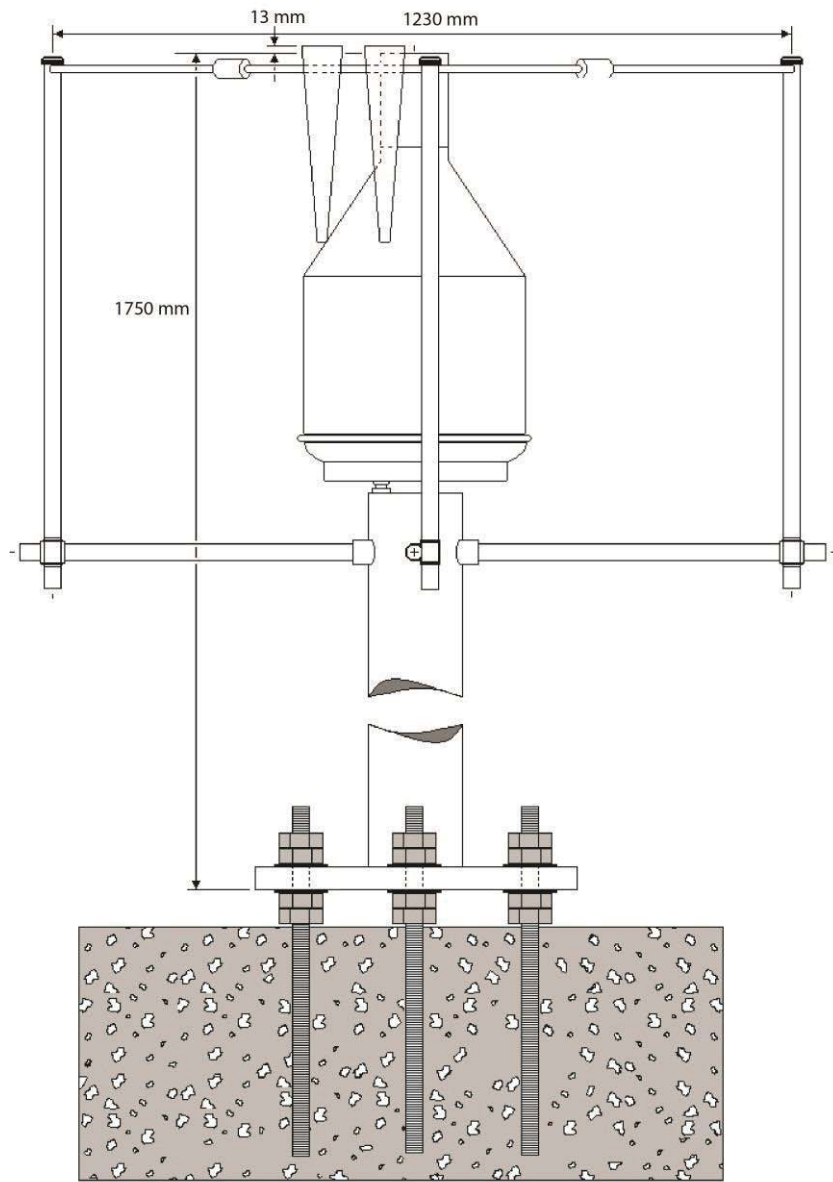

FIGURE 6—9. T-200B Precipitation Gauge with 1 m pedestal and 1.2 m Alter wind screen

## 7. Operation

### 7.1 Wiring

#### 7.1.1 Connecting Sensor to Transient Arrestor on Bucket Support Rim

**Note**

---

Leave enough slack in the wire so that it feeds straight up through the hole in the rim, and keeps the sensor still

---

1. Align the wire coming from the top of the sensor with the opening in the support rim. The wire will come straight up through the rim. Do not bend the wire more than shown.

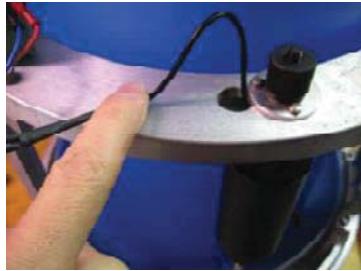

2. Connect the wire to the green transient arrestor box on the support rim.

**TABLE 7-1. Transducer / 455020 Transient Arrestor (on bucket support rim)**

Transducer	455020
Red (+)	6
Black (-)	4
	2 – no connection

Use wire clips or cable ties to secure wire to the rim.

#### 7.1.2 Connecting Wires from Transient Arrestor to Sensor Interface

Wires must be properly shielded, and be suitable to the environment in which they will be exposed. Campbell Scientific Canada can supply any cable length required.

1. Pass the cable through the strain-relief connector supplied through the base of the sensor.
2. Strip wires to appropriate length, if using a multi-pair cable
3. Run wires up the support through the opening in the rim to the transient arrestor

4. Connect wires as shown in Table 7-2

<b>TABLE 7-2. 455020 Transient Arrestor / 455060 Signal Interface (in datalogger enclosure)</b>	
<b>455020 Transient Arrestor</b>	<b>455060 Signal Interface</b>
5	A
3	B (next to A)
1 – no connection	
* also connect shield wire (clear) to B on 455060	

5. Repeat for each sensor

6. Remove slack and tighten strain-relief connector

If using a datalogger, we suggest grounding the shielding at the datalogger, not at the transient arrestor.

### 7.1.3 For Period Average Measurement

<b>TABLE 7-3. 455060 Signal Interface / Datalogger</b>	
<b>455060 Signal Interface</b>	<b>Datalogger</b>
E	Single-Ended Channel
F	AG
Either C terminal	SW12
B (next to V)	G

See programming examples in Sections 7.3.1 (1 sensor), and 7.3.2 (3 sensors).

### 7.1.4 For Pulse Count Measurement

<b>TABLE 7-4. 455060 Signal Interface / Datalogger</b>		
<b>455060 Signal Interface</b>	<b>Datalogger (CR800, CR1000, CR3000)</b>	<b>Datalogger (all others)</b>
V	Pulse or control port	Pulse port
B (next to V)	G	G
Either C terminal	SW12	SW12

See programming example in Section 7.3.3

## 7.2 Connecting the Datalogger or Manual Read-out Unit

The sensor is audible when power is supplied to it. Each transducer is slightly different, but the approximate range is from 1000 Hz (empty container) to 3000 Hz (full container).

1 kg or 1 L of water represents 50 mm of precipitation.

To calculate the amount of precipitation in mm from frequency, use the following equation:

$$P = (A (f - f_0) + B (f - f_0)^2) \times 10$$

Where:

P = precipitation (mm)

f = frequency reading (Hz)

A = calibration constant – given

B = calibration constant – given

f<sub>0</sub> = frequency with empty bucket at calibration (Hz) – given

Each sensor comes with its specific own Calibration Certificate.

## 7.3 Programming

The following program examples highlight two methods of making measurements with the T-200B-series of precipitation gauges. The measurement types include either a Period Average or a Pulse Count. Campbell Scientific recommends both types, and the selection used is typically based on channel availability on the datalogger.

As described in the three examples, it is recommended that measurements be taken every 5 seconds during the last 5 minutes of the each hour. However, these intervals can be adjusted as required. In each example an average and standard deviation is calculated for the depth of precipitation in millimetres. These values are output both hourly and daily.

### Note

---

Calibration constants must be added to the program for each sensor included with the T-200B. These constants can be found on the Calibration Certificate(s) included with the T-200B. It is also recommended to record the sensor serial numbers in the program for reference

---

### 7.3.1 T-200B 1 Sensor – Period Average Measurement Example

```
'Sample program for Geonor T-200B - 1 sensor version
'Period average measurement

'This program measures a Geonor T-200B weighing gauge for the last five minutes
'of every hour.
'The average and standard deviation of the depth values is calculated and recorded in
'hourly and daily output data tables.

'ENTER SENSOR SERIAL NUMBERS
'T-200B - SN XXXXX

'ENTER SENSOR SPECIFIC CALIBRATION CONSTANTS
Const Geonor_f0 = 1050
Const Geonor_A = 1.7E-2
Const Geonor_B = 9.2E-6

'Declare Public Variables and Units
'Datalogger panel temperature
Public PTemp
Units PTemp = degC

'Datalogger power supply voltage
Public Batt_Volt
Units Batt_Volt = V

'Raw frequency from the transducer
Public Geonor_Freq
Units Geonor_Freq = Hz

'Unprocessed depth from the transducer
Public Geonor_Depth_Raw
Units Geonor_Depth_Raw = mm

'Processed depth values for the Geonor gauge
Public Geonor_Processing_5min(2)
Alias Geonor_Processing_5min(1) = Geonor_Depth_Average
Alias Geonor_Processing_5min(2) = Geonor_Depth_StdDev
Units Geonor_Processing_5min(1) = mm

'This flag controls when the Geonor is turned on and measured
'Automatically turns on for the last 5 minutes of each hour, and can be turned on
'manually outside of that time for testing purposes
Public Measure_Geonor_Flag As Boolean

'This variable is for the warm-up delay of the sensor
Dim Geonor_warmup

'Define Geonor Processing Table
'This table is used to calculate the average and standard deviation of the depth values
DataTable (Geonor_processing,1,1)
  DataInterval (0,5,Min,10)
  Average (1,Geonor_Depth_Raw,IEEE4,False)
  StdDev (1,Geonor_Depth_Raw,FP2,False)
EndTable

'Define Output Data Tables
DataTable(Hourly,1,-1)
  DataInterval(0,1,hr,10)
  Sample(1,Geonor_Depth_Average,IEEE4)
  Sample(1,Geonor_Depth_StdDev,FP2)
  Sample(1,Geonor_Freq,IEEE4)
EndTable

DataTable(Daily,1,-1)
  DataInterval(0,1,day,10)
  Sample(1,Geonor_Depth_Average,IEEE4)
```

```

Sample(1,Geonor_Depth_StdDev,FP2)
Sample(1,Geonor_Freq,IEEE4)
EndTable

'Main Program
BeginProg
Scan (5,Sec,0,0)
  PanelTemp (PTemp,_60Hz)
  Battery (Batt_Volt)

  'Set flag to true power on and measure the Geonor 5 minutes before the top of the hour
  If TimeIntoInterval(55,60,min) Then
    Measure_Geonor_Flag = true
  EndIf

  If Measure_Geonor_Flag = true Then
    'Power on sensor
    SW12(1)

    'Start 15 second warmup delay
    Geonor_warmup = Timer (1,Sec,0)

    'Start measuring the gauge after 15 second warm-up
    If Geonor_warmup >= 15 Then
      'Measure Geonor sensor using Period Average (single ended channel - e.g. SE1)
      PeriodAvg (Geonor_Freq,1,mV250,1,0,1,1000,1000,1,0)

      'Convert to Depth using the calibration equation [mm]
      Geonor_Depth_Raw = (Geonor_A * (Geonor_Freq - Geonor_f0) + Geonor_B * (Geonor_Freq -
Geonor_f0) ^2 ) * 10

      'Call Geonor processing table
      CallTable Geonor_Processing
    EndIf
  Else
    'Power off sensor
    SW12(0)
    'Reset warm-up timer
    Geonor_warmup = Timer(1,Sec,3)
  EndIf

  'At the top of each hour, do the following:
  'set flag to false to power down and stop measuring the Geonor,
  'and retrieve the average and standard deviation values
  If TimeIntoInterval(0,60,min) Then
    Measure_Geonor_Flag = false
    GetRecord (Geonor_Processing_5min,Geonor_Processing,1)
  EndIf

  'Call output data tables
  CallTable Hourly
  CallTable Daily

NextScan
EndProg

```

### 7.3.2 T-200B 3 Sensor – Period Average Measurement Example

```

'Sample program for Geonor T-200B - 3 sensor version

'This program measures a Geonor T-200B weighing gauge for the last five minutes
'of every hour.
'The average and standard deviation of the depth values is calculated and recorded in
'hourly and daily output data tables.

'ENTER SENSOR SERIAL NUMBERS

```

```

'T-200B-1 (T1) - SN XXXXX
'T-200B-2 (T2) - SN XXXXX
'T-200B-3 (T3) - SN XXXXX

'ENTER SENSOR SPECIFIC CALIBRATION CONSTANTS
Const T1_f0 = 1050
Const T1_A = 1.7E-2
Const T1_B = 9.2E-6

Const T2_f0 = 1050
Const T2_A = 1.7E-2
Const T2_B = 9.2E-6

Const T3_f0 = 1050
Const T3_A = 1.7E-2
Const T3_B = 9.2E-6

'Declare Public Variables and Units
'Datalogger panel temperature
Public PTemp
Units PTemp = degC

'Datalogger power supply voltage
Public Batt_Volt
Units Batt_Volt = V

'Raw frequencies from the individual transducers
Public T1_Freq, T2_Freq, T3_Freq
Units T1_Freq = Hz
Units T2_Freq = Hz
Units T3_Freq = Hz

'Unprocessed depths from the individual transducers
Public T1_Depth_Raw, T2_Depth_Raw, T3_Depth_Raw
Units T1_Depth_Raw = mm
Units T2_Depth_Raw = mm
Units T3_Depth_Raw = mm

'Processed depth values for the individual transducers
Public Geonor_Processing_5min(6)
Alias Geonor_Processing_5min(1) = T1_Depth_Average
Alias Geonor_Processing_5min(2) = T2_Depth_Average
Alias Geonor_Processing_5min(3) = T3_Depth_Average
Alias Geonor_Processing_5min(4) = T1_Depth_StdDev
Alias Geonor_Processing_5min(5) = T2_Depth_StdDev
Alias Geonor_Processing_5min(6) = T3_Depth_StdDev
Units Geonor_Processing_5min(1) = mm

'Processed overall depth values for the Geonor gauge
Public Geonor_Depth_Average
Public Geonor_Depth_StdDev
Units Geonor_Depth_Average = mm
Units Geonor_Depth_StdDev = mm

'This flag controls when the Geonor is turned on and measured
'Automatically turns on for the last 5 minutes of each hour, and can be turned on
'manually outside of that time for testing purposes
Public Measure_Geonor_Flag As Boolean

'This variable is for the warm-up delay of the sensor
Dim Geonor_warmup

'Define Geonor Processing Table
'This table is used to calculate the averages and standard deviations of the
'individual depth values
DataTable (Geonor_processing,1,1)
  DataInterval (0,5,Min,10)
  Average (1,T1_Depth_Raw,IEEE4,False)

```

```

Average (1,T2_Depth_Raw,IIEEE4,False)
Average (1,T3_Depth_Raw,IIEEE4,False)
StdDev (1,T1_Depth_Raw,FP2,False)
StdDev (1,T2_Depth_Raw,FP2,False)
StdDev (1,T3_Depth_Raw,FP2,False)
EndTable

'Define Output Data Tables
DataTable(Hourly,1,-1)
DataInterval(0,1,hr,10)
Sample(1,Geonor_Depth_Average,IIEEE4)
Sample(1,Geonor_Depth_StdDev,FP2)
Sample(1,T1_Depth_Average,IIEEE4)
Sample(1,T2_Depth_Average,IIEEE4)
Sample(1,T3_Depth_Average,IIEEE4)
Sample(1,T1_Depth_StdDev,FP2)
Sample(1,T2_Depth_StdDev,FP2)
Sample(1,T3_Depth_StdDev,FP2)
Sample(1,T1_Freq,IIEEE4)
Sample(1,T2_Freq,IIEEE4)
Sample(1,T3_Freq,IIEEE4)
EndTable

DataTable(Daily,1,-1)
DataInterval(0,1,day,10)
Sample(1,Geonor_Depth_Average,IIEEE4)
Sample(1,Geonor_Depth_StdDev,FP2)
Sample(1,T1_Depth_Average,IIEEE4)
Sample(1,T2_Depth_Average,IIEEE4)
Sample(1,T3_Depth_Average,IIEEE4)
Sample(1,T1_Depth_StdDev,FP2)
Sample(1,T2_Depth_StdDev,FP2)
Sample(1,T3_Depth_StdDev,FP2)
Sample(1,T1_Freq,IIEEE4)
Sample(1,T2_Freq,IIEEE4)
Sample(1,T3_Freq,IIEEE4)
EndTable

'Main Program
BeginProg
Scan (5,Sec,0,0)
  PanelTemp (PTemp,_60Hz)
  Battery (Batt_Volt)

  'Set flag to true power on and measure the Geonor 5 minutes before the top of the hour
  If TimeIntoInterval(55,60,min) Then
    Measure_Geonor_Flag = true
  EndIf

  If Measure_Geonor_Flag = true Then
    'Power on sensor
    SW12(1)

    'Start 15 second warmup delay
    Geonor_warmup = Timer (1,Sec,0)

    'Start measuring the gauge after 15 second warm-up
    If Geonor_warmup >= 15 Then
      'Measure sensor T1 using Period Average (single ended channel - SE1)
      PeriodAvg (T1_Freq,1,mV250,1,0,1,1000,1000,1,0)
      'Convert to Depth using the calibration equation [mm]
      T1_Depth_Raw = (T1_A * (T1_Freq - T1_f0) + T1_B * (T1_Freq - T1_f0) ^2 ) * 10

      'Measure sensor T2 using Period Average (single ended channel - SE2)
      PeriodAvg (T2_Freq,1,mV250,2,0,1,1000,1000,1,0)
      'Convert to Depth using the calibration equation [mm]
      T2_Depth_Raw = (T2_A * (T2_Freq - T2_f0) + T2_B * (T2_Freq - T2_f0) ^2 ) * 10
    EndIf
  EndIf
EndProg

```

```

'Measure sensor T3 using Period Avg (single ended channel - SE3)
PeriodAvg (T3_Freq,1,mV250,3,0,1,1000,1000,1,0)
'Convert to Depth using the calibration equation [mm]
T3_Depth_Raw = (T3_A * (T3_Freq - T3_f0) + T3_B * (T3_Freq - T3_f0) ^ 2 ) * 10

'Call Geonor processing table
CallTable Geonor_Processing
EndIf
Else
'Power off sensor
Sw12(0)
'Reset warm-up timer
Geonor_warmup = Timer(1,Sec,3)
EndIf

'At the top of each hour, do the following:
'set flag to false to power down and stop measuring the Geonor,
'and retrieve the average and standard deviation values
If TimeIntoInterval(0,60,min) Then
Measure_Geonor_Flag = false
GetRecord (Geonor_Processing_5min,Geonor_processing,1)
EndIf

'Calculate the overall average and standard deviation for the Geonor gauge
Geonor_Depth_Average = (T1_Depth_Average + T2_Depth_Average + T3_Depth_Average) / 3
Geonor_Depth_StdDev = SQR( (T1_Depth_StdDev^2 + T2_Depth_StdDev^2 + T3_Depth_StdDev^2) /
3 )

'Call output data tables
CallTable Hourly
CallTable Daily

NextScan
EndProg

```

### 7.3.3 T-200B Pulse Count Measurement Example

```

'Sample program for Geonor T-200B - 1 sensor version
'Period average measurement

'This program measures a Geonor T-200B weighing gauge for the last five minutes
'of every hour.
'The average and standard deviation of the depth values is calculated and recorded in
'hourly and daily output data tables.

'ENTER SENSOR SERIAL NUMBERS
'T-200B - SN XXXXX

'ENTER SENSOR SPECIFIC CALIBRATION CONSTANTS
Const Geonor_f0 = 1050
Const Geonor_A = 1.7E-2
Const Geonor_B = 9.2E-6

'Declare Public Variables and Units
'Datalogger panel temperature
Public PTemp
Units PTemp = degC

'Datalogger power supply voltage
Public Batt_Volt
Units Batt_Volt = V

```

```

'Raw frequency from the transducer
Public Geonor_Freq
Units Geonor_Freq = Hz

'Unprocessed depth from the transducer
Public Geonor_Depth_Raw
Units Geonor_Depth_Raw = mm

'Processed depth values for the Geonor gauge
Public Geonor_Processing_5min(2)
Alias Geonor_Processing_5min(1) = Geonor_Depth_Average
Alias Geonor_Processing_5min(2) = Geonor_Depth_StdDev
Units Geonor_Processing_5min(1) = mm

'This flag controls when the Geonor is turned on and measured
'Automatically turns on for the last 5 minutes of each hour, and can be turned on
'manually outside of that time for testing purposes
Public Measure_Geonor_Flag As Boolean

'This variable is for the warm-up delay of the sensor
Dim Geonor_warmup

'The first PulseCount instruction of each hour does not provide a valid output. This flag
'prevents the first output from being used in any calculations for precipitation depth.
Dim FirstPulseCount As Boolean

'Define Geonor Processing Table
'This table is used to calculate the average and standard deviation of the depth values
DataTable (Geonor_processing,1,1)
  DataInterval (0,5,Min,10)
  Average (1,Geonor_Depth_Raw,IIEEE4,FirstPulseCount)
  StdDev (1,Geonor_Depth_Raw,FP2,FirstPulseCount)
EndTable

'Define Output Data Tables
DataTable(Hourly,1,-1)
  DataInterval(0,1,hr,10)
  Sample(1,Geonor_Depth_Average,IIEEE4)
  Sample(1,Geonor_Depth_StdDev,FP2)
  Sample(1,Geonor_Freq,IIEEE4)
EndTable

DataTable(Daily,1,-1)
  DataInterval(0,1,day,10)
  Sample(1,Geonor_Depth_Average,IIEEE4)
  Sample(1,Geonor_Depth_StdDev,FP2)
  Sample(1,Geonor_Freq,IIEEE4)
EndTable

'Main Program
BeginProg

  Scan (5,Sec,0,0)
    PanelTemp (PTemp,_60Hz)
    Battery (Batt_Volt)

    'Set flag to true power on and measure the Geonor 5 minutes before the top of the hour
    If TimeIntoInterval(55,60,min) Then
      Measure_Geonor_Flag = true
      FirstPulseCount = true
    EndIf

    If Measure_Geonor_Flag = true Then
      'Power on sensor
      SW12(1)

      'Start 15 second warmup delay
      Geonor_warmup = Timer (1,Sec,0)
    EndIf
  EndScan
EndProg

```

```

'Start measuring the gauge after 15 second warm-up
If Geonor_warmup >= 15 Then
'Measure Geonor sensor using PulseCount (pulse channel or control port - e.g. P1)
PulseCount (Geonor_Freq,1,1,0,1,1.0,0)
'Convert to Depth using the calibration equation [mm]
Geonor_Depth_Raw = (Geonor_A * (Geonor_Freq - Geonor_f0) + Geonor_B * (Geonor_Freq -
Geonor_f0) ^2 ) * 10
EndIf
Else
'Power off sensor
SW12(0)
'Reset warm-up timer
Geonor_warmup = Timer(1,Sec,3)
EndIf

'Call Geonor processing table
CallTable Geonor_Processing

If Geonor_warmup >= 15 Then
FirstPulseCount = false
EndIf

'At the top of each hour, do the following:
'set flag to false to power down and stop measuring the Geonor,
'and retrieve the average and standard deviation values
If TimeIntoInterval(0,60,min) Then
Measure_Geonor_Flag = false
GetRecord (Geonor_Processing_5min,Geonor_Processing,1)
EndIf

'Call output data tables
CallTable Hourly
CallTable Daily

NextScan
EndProg

```

## 8. Troubleshooting and Maintenance

### 8.1 Tools

Tools required:

- Screw driver 4 mm blade
- Hammer
- Adjustable wrench (0 – 27 mm)
- Waste container for disposal of antifreeze (at least 12 L)
- Funnel
- 1 L measuring cylinder

Tools supplied:

- Siphon pump
- Level

### 8.2 Service Interval

At a minimum, inspection is recommended twice a year. The sensor should also be serviced when the container needs to be emptied.

Remove the cover (see Section 6.5.1) and tighten transducer setscrew to avoid damaging the vibrating wire.

It may be easier to service the sensor by removing the Alter wind screen from 3 of the 4 posts.



FIGURE 8—1. Removing the Alter wind screen from 3 of 4 posts

## 8.2.1 Cleaning the Container

### Note

---

If the oil in the container does not need to be replaced there is no need to remove it

---

Use the siphon pump to remove liquid from the the container. Place the shorter end at the bottom of the bucket. Holding the receptacle at a lower level than the bucket pump the siphon will start to flow. Once the flow has started there is no need to pump, simply wait until you have removed the proper amount. You can also empty the bucket by hand. Be careful not to overload the VW load cell, or subject it to any shock.

Clean the container, and add antifreeze mixture and oil, as required. Replace carefully in the weighing dish aligning the black dot on the rim of the bucket, with the black dot on the support rim.

### Note

---

Loosen the setscrew on the transducer

---

Replace the gauge cover, and lock the 3 clamps.

## 8.3 Checking Sensor Function

### 8.3.1 Empty Bucket Check

1. Level the bucket accurately

2. Check the frequency of the empty bucket ( $f_0$ -value) using a datalogger or a Geonor P-520N portable counter
3. Compare the empty bucket  $f_0$ -value with  $f_0$ -value on the Calibration Certificate for the transducer. If the difference is equal to or less than 10 Hz, no adjustment is necessary. If the difference exceeds 10 Hz, a new value for constant A should be calculated. Use the new  $f_0$ -value and the new A in your calculations.

**Formula for Calculating a New Constant A with the new  $f_0$**

$$A' = A + 2B(f_0' - f_0)$$

Where  $A'$  and  $f_0'$  are new values, and  $A$ ,  $B$  and  $f_0$  are the original calibration values.

### 8.3.2 Full Bucket Check

1. Fill the container with 1 kg of water. If the water is free of air, it equals 1 L of water. Tap water can contain considerable amounts of air. Boiling the water for 10 min will remove most of the air. 1 kg of water represents exactly 50 mm of precipitation.
2. Recalibrate the sensor if it differs by more than 0.5% from the value on the Calibration Certificate.

## 8.4 Removing and Replacing the Transducer

**Note**

---

When installing a new or recalibrated sensor, use the new values for A, B, and  $f_0$ : provided on the Calibration Certificate

---

1. Remove gauge cover
2. Tighten setscrew
3. Carefully remove container
4. Disconnect electrical leads from transient arrestor
5. Unhook the S-hook from the support dish
6. Hold the sensor and remove black knurled nut from the top of the adjustment screw
7. Remove the sensor from the square guide in the support rim

Install a new sensor in the reverse order

## **8.5 Rust Protection Maintenance**

For added protection, apply two layers of rust-preventing coating such as paint, zinc-galvanizing spray, or similar on all threaded parts of the pedestal and Alter wind screen.

# Appendix A. Alter Wind Screen Diagrams

## A.1 Precipitation Gauge Wind Shield Assembly

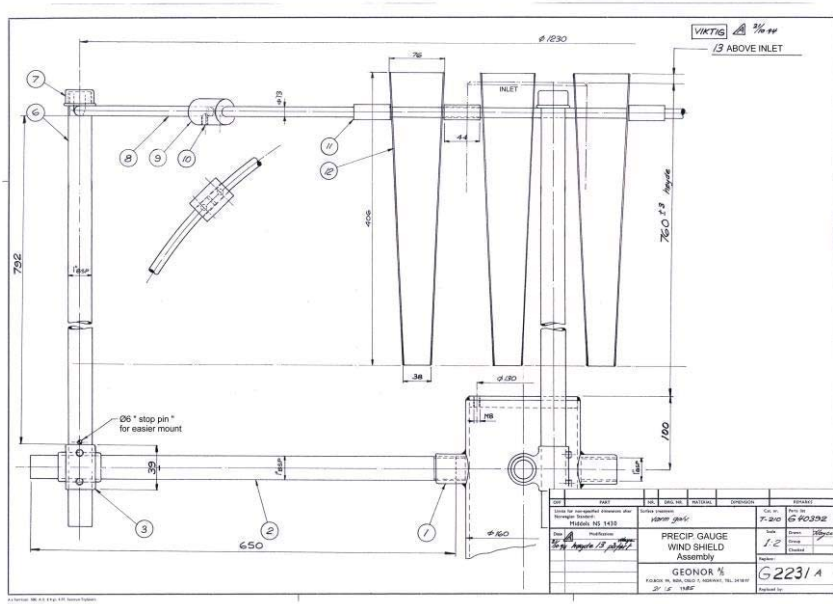

## A.2 Precipitation Gauge Wind Shield Segment

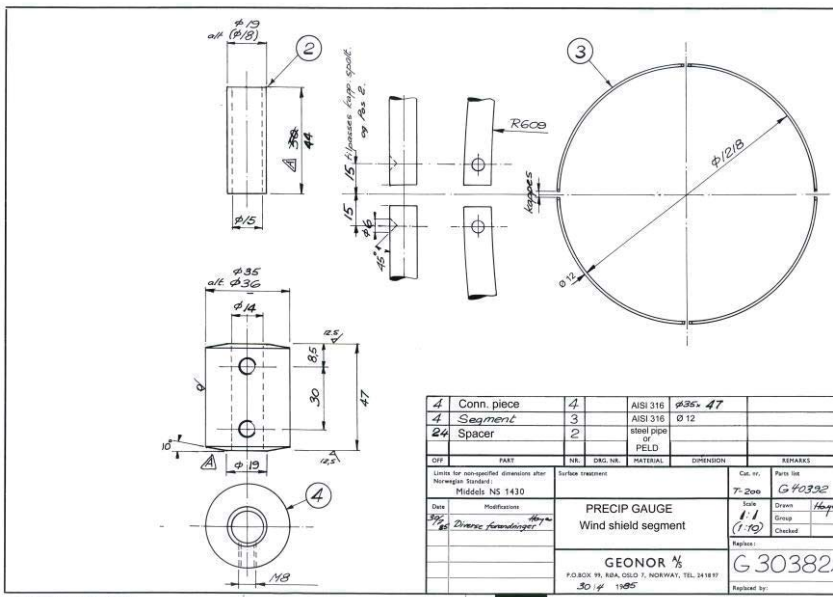

### A.3 Alter Wind Screen Blade

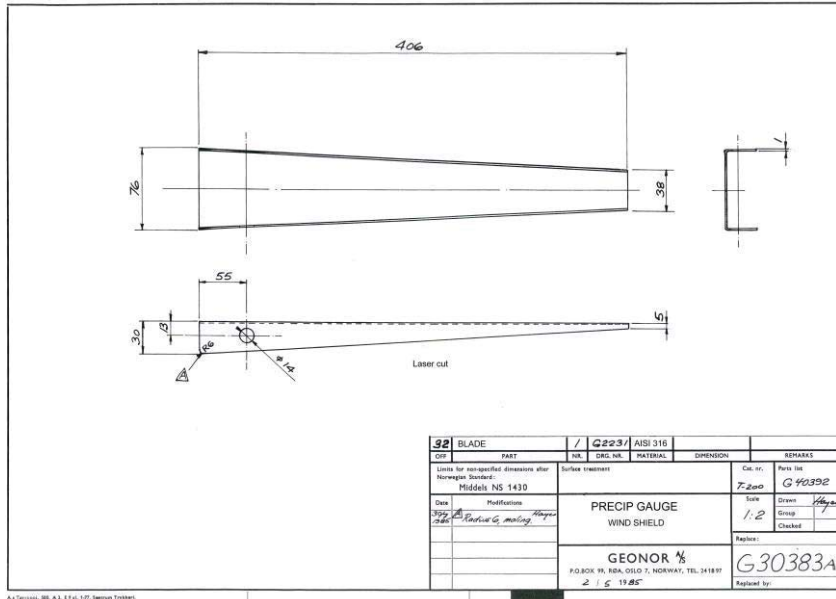

### A.4 Precipitation Gauge Pedestal

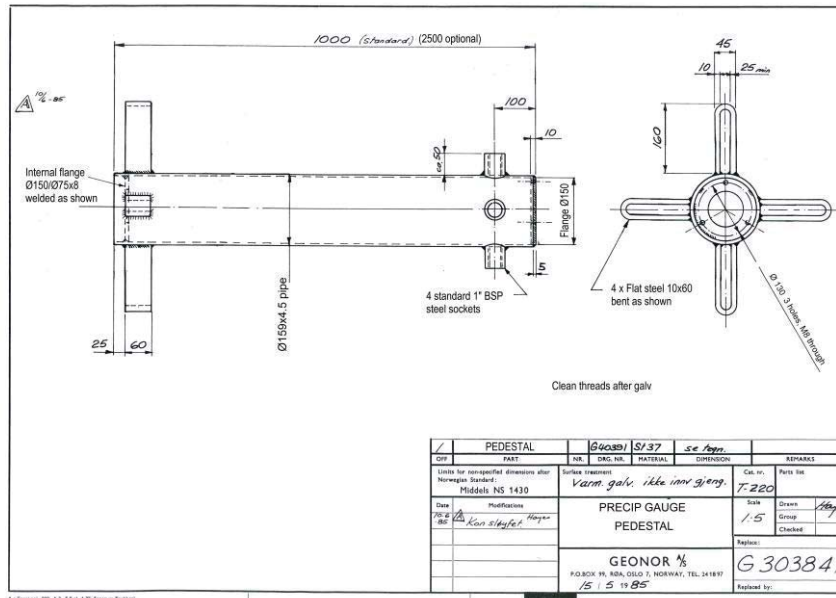



**CAMPBELL<sup>®</sup>  
SCIENTIFIC**

Campbell Scientific (Canada) Corp. | 14532 131 Avenue NW | Edmonton AB T5L 4X4 | 780.454.2505 | [www.campbellsci.ca](http://www.campbellsci.ca)  
AUSTRALIA | BRAZIL | CANADA | COSTA RICA | FRANCE | GERMANY | SOUTH AFRICA | SPAIN | UNITED KINGDOM | USA