

A MULTIPOINT SNOW DEPTH MEASUREMENT SYSTEM

Byung Moo Kim⁽¹⁾, Chun Woo Lee⁽¹⁾, Chang Joo Lee⁽²⁾, and Jiyoung Choi⁽³⁾

⁽¹⁾ Weatherpia Co. Ltd., 7 Boramero 5ga-gil, Gwank-gu Character-Greenville, Suite 1113, Seoul, Korea

T: +82-2-876-0407 F: +82-876-0408 email: 2bmkim@gmail.com (BM Kim) 2005u@naver.com (CW Lee)

⁽²⁾ Dongyang Mirae University, Dept. of Information & Communication, 445 Gyeongin-ro, Guro-gu, Seoul, Korea

T: +82-2-2610-1794 F: +82-2-2610-1854 email: cjlee@dongyang.ac.kr

⁽³⁾ Korea Meteorological Administration, 61 Yeouidaebang-ro 16-gil, Dongjak-gu, Seoul, Korea

T: +82-2-2181-0729 F: +82-2-841-7045 email: chjy1052@korea.kr <mailto:cjlee@dongyang.ac.kr>

ABSTRACT

The multipoint scanning scheme is an ideal solution for laser based measurement of snow depth. However, due to the complexity and high cost of implementation and operation of such systems, very few have been introduced in real fields. A compact automated snow depth measurement system with multipoint scanning capability has been developed and tested during two winter seasons in real fields. This system employs a custom designed laser distance meter and a unique mechanical structure combined with intelligent algorithms to efficiently scan multiple points on a target area for accurate and reliable snow depth measurements. Field test results with typical events during 2013-2014 winter season are presented to demonstrate how the new multipoint scanning snow gauge has improved performance in various aspects of snow depth measurement. Besides increased sensitivity and consistency of measurements, the proposed solution effectively filters out erroneous samples and improves detection of events such as new snowfalls. In addition to automated measurement results by four experimental systems located at two sites, data collected by manual observations, captured images by cameras, and ancillary meteorological data were used to compare and analyze the automatic snow depth measurements data.

I. INTRODUCTION

For the past years, various automatic snow depth measurement systems or gauges have been deployed and tested at different places to take advantages of their efficiency and more objective measurement results. But, expansion of such deployment and utilization of these automatic snow gauges has been limited due to challenges in the real fields including the following two:

First, certain technologies don't provide enough accuracy and consistency in measuring depth of snow and/or detecting new snowfall events especially when there are influencing factors such as temperature and difference in the type/density of snow.

Secondly, even though certain technologies such as the laser measurement technology offer high precision and accuracy required for automatic measurement of snow depth, many test results have revealed issues caused by measuring only a single point. It has been discussed in many research works that snow depths can vary significantly inside a target area, and it would actually be necessary to measure at different locations simultaneously to determine a meaningful average value. [1][4] Therefore there have been various suggestions that it would be favorable if the laser gauge could scan the beam over a larger area or several measurement points, but, they also mentioned that it would be a challenge for manufacturers to build such a scanning laser snow depth gauge in a cost effective way.

The research work presented in this paper has been started to solve this problem with a practical multipoint scanning laser gauge scheme. This presentation will discuss the concept of the practical multipoint laser snow gauge and the results from its field test during 2013-2014 winter season.

II. EQUIPMENT

Theory of Operation

Figure 1 shows SDMS-10, the first version of our multipoint scanning snow gauge used for field tests in this research. As shown in Figure 1, the snow gauge scans the laser beam on a circular path on the surface of snow and measures distance from each point on the path and provides the average of the depths at these points.

A unique mechanical structure was designed and structured to provide a cost effective and simple solution for a 2-D multipoint snow gauge. In this mechanical structure, a laser distance meter is attached to a motor in a slightly tilted (slanted) fashion so that, as the motor turns, the transmitted laser signal from the laser distance meter points at different spots on a circular path on the surface of snow. This scheme allows snow depth measurements on multiple points scattered along the circular shape on the surface of snow in a simple way. The size of the circular shape on the surface of snow varies depending on the distance between the laser distance meter and the surface of snow and the angle between the laser beam and the shaft of the motor.

Figure 2 shows how the direction of a laser signal from the laser distance meter and the reflected signal are changed as the motor rotates due to tilted attachment of the laser distance meter to the shaft of the motor.

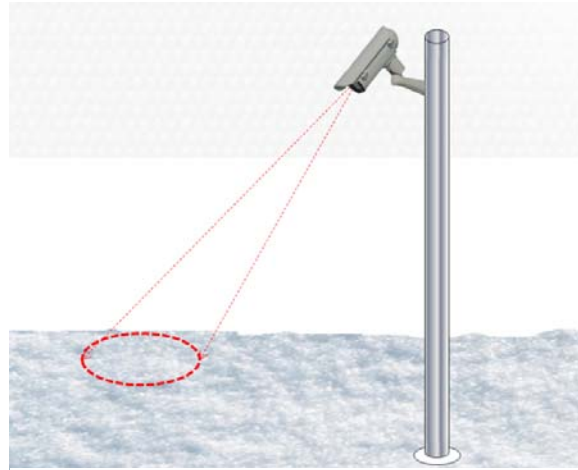

Figure 1 SDMS-10, the first version of our multipoint scanning snow depth gauge used for the field tests

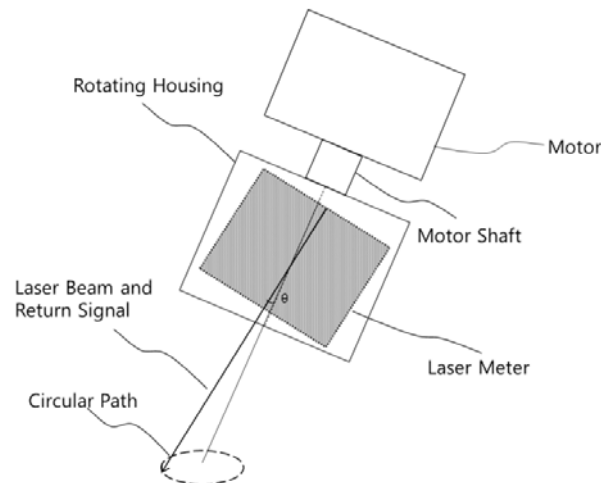

Figure 2 The laser distance meter attached to the shaft of a motor tilted by an angle, θ

Figure 3 is a diagram showing a single laser beam projected by and reflected back to the laser distance meter from a spot on the surface of the snow at a given time t . If the measured distance from the laser distance meter to the surface of snow is $L_s(t)$ at a certain time t , and $L_g(t)$ is the distance to the ground level, and $\theta(t)$ is the tilt angle at time t , then the depth of the snow is derived as follows:

Depth of snow at t , $d(t) = (L_g(t) - L_s(t)) \times \sin [\theta(t)]$

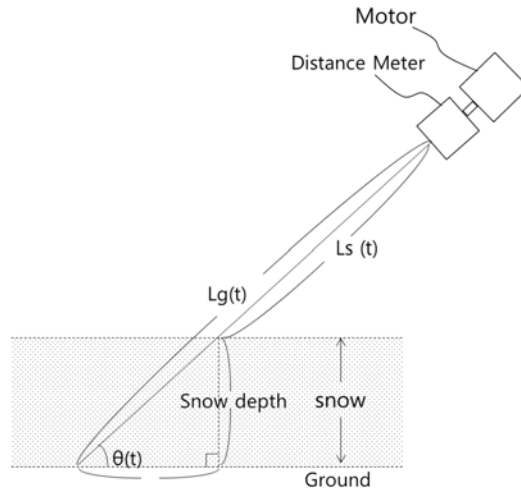

Figure 3 A single laser beam and the return signal for distance measurement at a given time t

For measurement of the next points on the circular path, as shown in Figure 4, the controller of the snow gauge rotates the motor by an angle, Φ , and repeats the above measurement and calculation. The system repeats the same step for $t = 0$ to $t = N - 1$ until it finishes the intended number of measurements, N , for the round. If the degree of rotation between two neighboring points is given by Φ , and the total rotation of a round is 360 degrees, Φ is given as by $\Phi = \frac{360}{N}$, or $\Phi * N = 360$. Figure 4 shows how measurements are done for all the points for $t = 0$ to $N - 1$, ($t\Phi$ in circular angle).

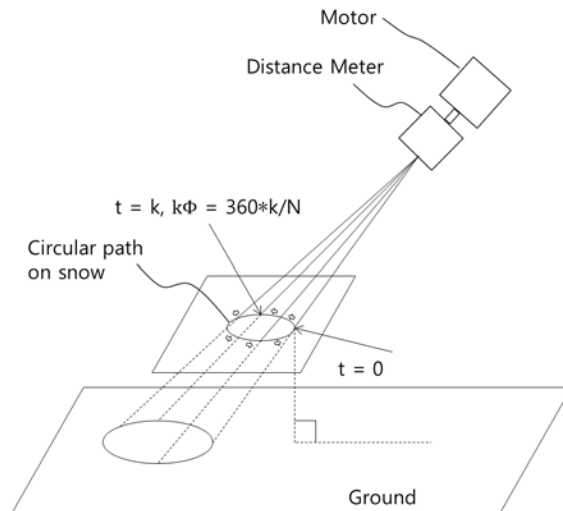

Figure 4 A round of measurements along a circular shape

At each time t (circular angle $t\Phi$),

$d(t) = (L_g(t) - L_s(t)) * \sin [\theta(t)]$ where $t = 0$ to $N - 1$, where,

$N =$ number of samples along the circular path on the target surface, and $L_g(t)$ for

$t = 0$ to $N-1$ (circular angle $\phi = 0$ to 360) and $\theta(t)$ are already determined by a calibration procedure.

Once a round of measurements is completed, the processing module filters out abnormal data and take an average and determine the current snow depth based on a set of rules and history data. The system may repeat the steps several times to increase reliability of the final data, and the system stores measurement data in its local storage and/or uploads them to the remote server for further analysis and presentation on its website.

SDMS-20

The system uses a custom designed laser distance meter, a special mechanism and other hardware to make the end product small and light while keeping the total solution cost effective even with the complicated multipoint scanning capability. Figure 5 shows the latest version of our snow gauge head with size of 8cm x 8cm x 15cm and weight of 1.5kg. The details on how to implement the multipoint scanning snow gauge are beyond the scope of this presentation and will be discussed on a different occasion.

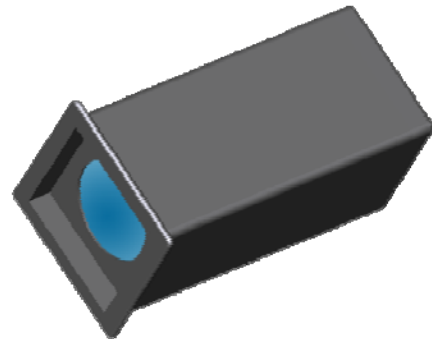

Figure 5 SDMS-20, a smaller and lighter version of SDMS-10 with more features (Size: 8cm x 8cm x 15cm Weight: 1.5 kg)

III. FIELD TEST SETUP

Field Test Sites

Field tests of the multipoint snow gauges during winter 2013-2014 have been performed at four different sites in Korea as listed in Table 1. The main factors considered for selection of these sites were the availability of other references at the sites and distinct difference in snow precipitation patterns. Based on the criteria, two locations were selected. One of these locations in the northern part of the country has heavy snow in winter and snow depth reaches two meters easily. And the other one is located in the southern part of the country, and it has more frequent snow, but, snow melts relatively quickly and doesn't accumulate much. As shown in Table 1, we've deployed two snow gauges at each of these locations.

Site	Location	Climate characteristics	Reference Zero-Level
1	Gochang	Warm and frequent snow	Snow plate
2	Gochang	Warm and frequent snow	Natural ground
3	Daekwanryeong Observatory	Cold, heavy snow and strong wind	Natural ground
4	Daekwanryeong (CPRC)	Cold, heavy snow	Grass

Table 1 Four field test sites

Installation

The snow gauges were collocated with other existing snow gauges and mounted on poles at heights of approximately two (2) meters above ground. For each site, the inclination angle was between 30° - 45° off the vertical line to make sure that the target area is at an enough distance from the installation structure or the equipment. We've observed that an inclination angle anywhere between 20° and 50° works well with the multipoint snow gauge. All four snow gauges were configured to measure 36 points on circular paths to determine the average snow depth.

Site 1 was setup with a wooden snow plate for the zero-level reference, and Site 2 and Site 3 had the zero-level reference on the bare ground. At Site 4, we used the natural grass as the zero-level for the multipoint measurement. Figure 6 shows the setup for the field test equipment at Site1 and Site 2, Figure 7 shows the setup for Site 3 and Site 4.

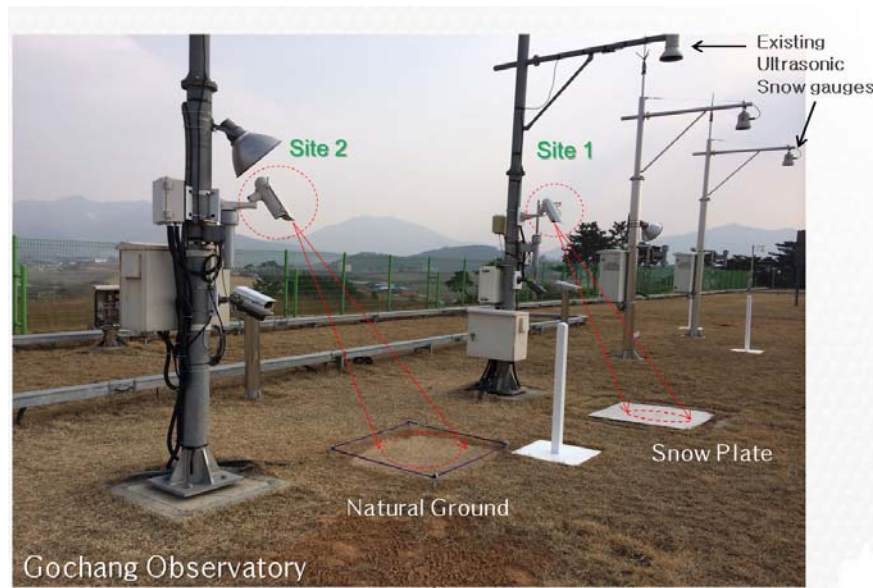

Figure 6 Site 1 and 2 at Gochang Observatory in southern part of Korea



Figure 7 Site 3 and 4 at Daekwanryeong area in north-eastern part of Korea

Data Collection and Processing

As a multipoint snow gauge performs measurements at the target areas, it first captures raw data at the sample points along the circular shaped path, and then it applies filtering and processing algorithms to get meaningful average snow depth data.

Measurements and uploads have been executed every 1 or 2 minutes. Both raw data and results of data processing along with other environmental information data such as air temperature have been uploaded to the main server for further processing and presentation to our website. We've used official measurement data by the observatories at the sites as a reference.

IV. TEST RESULTS

Multipoint Scanning vs. Single Point Measurement

Figure 8 through Figure 10 show snow depths at all 36 points on the scanning paths on the ground or the surface of snow at site 3 at 11:00AM on February 6 through February 8 in 2014. These test results clearly illustrate why a multipoint scanning snow gauge can outperform a single point laser snow gauge and provide more meaningful representative snow depth data for a target location.

The measurement data in Figure 8 was captured right after an automatic ground-level adjustment. One can assume that all points would be at the zero-level, but, in reality, the measurement depths at the points were between -2 mm and 2mm. The errors or deviations are partly due to irregular scattering or reflection of the laser signal and partly due to the error added by the laser distance meter itself. As there was more precipitation and the snow depth reached 7.3 cm, the error became bigger and some point showed 8.2cm and 6.4cm with a maximum difference of 1.8cm. When the snow depth reached 41.1cm, the difference between the points reached almost 3cm. If we measured only on point on the snow, any arbitrary one of these points would have been the representative snow depth on the site.

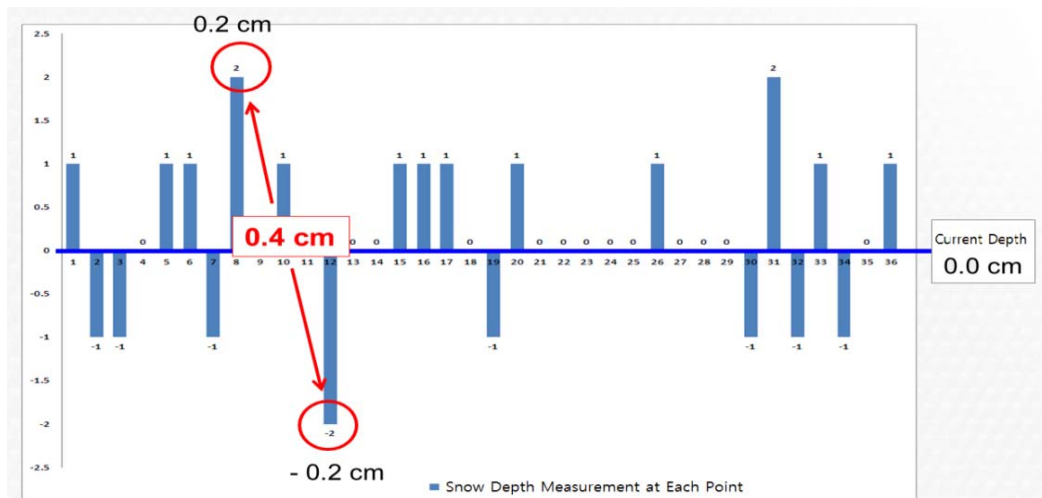

Figure 8 Measurements at 36 points at the average depth = 0 cm, Site 3 at 11:00 am on 2/6/2014

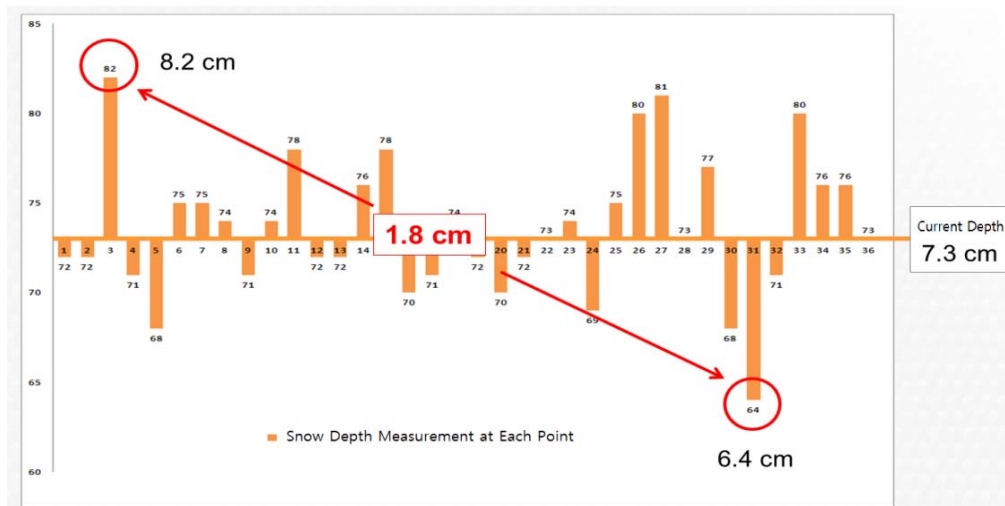

Figure 9 Measurements at 36 points at the average depth = 7.3cm, Site 3 at 11:00 am on 2/7/2014

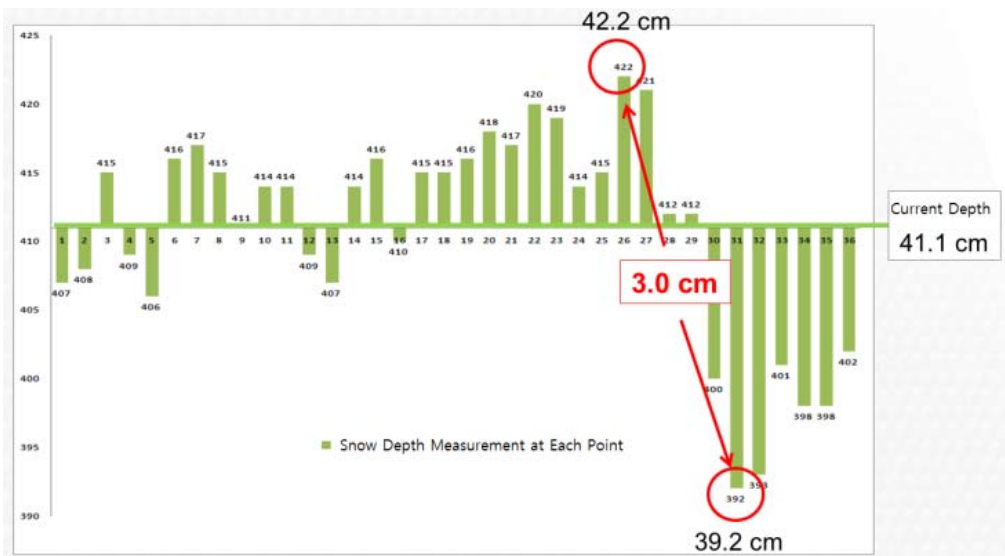

Figure 10 Measurements at 36 points at the average depth = 41.1cm, Site 3 at 11:00 am on 2/8/2014

Case Studies

In this this section, three distinct snowfall events during the field test period are presented.

(1) Heavy snow fall (7 - 8 February, 2014) at site 3 and 4

This snowfall event was recorded at site 3 on February 7 and 8, 2014, the first two days of the record high snowfall in the region. The automatic measurement data by the snow gauge was compared with the manual measurement data, and, as an additional reference, we've installed a scale and recorded reading of the scale using an IP camera. As show in Figure 11, the measurement data from the snow gauge matched the results of manual measurement by officials at the sites and captured data from the camera. Manual measurements were done on a different spot with a snow plate and a scale a few meters apart from our gauge.

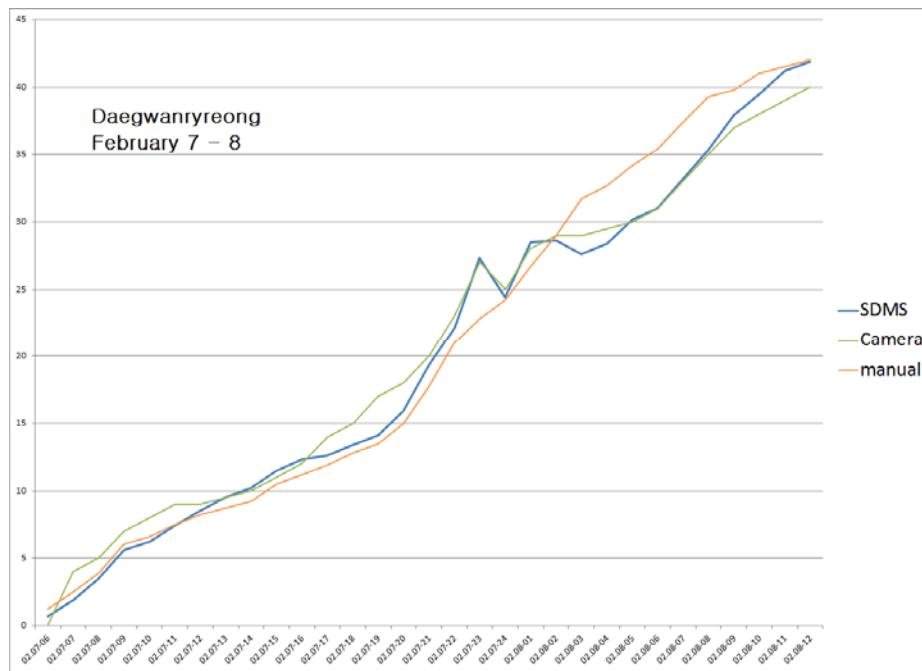

Figure 11 Measurements at site 3 on 2/7/2014 and 2/8/2014 unit: mm

(2) New snow fall (20 Jan, 2014) at Site 1 and 2

As shown in Figure 12, new snowfall was observed and recorded around at 18:50 on Jan 20, 2014. Due to the different types of the zero-level reference, two sites showed different performance in detecting the new snowfall. Detection of the new snowfall by the snow gauge at Site 1 installed with a snow plate didn't happen until there was 0.2 - 0.3 cm of snow. But, as shown in the data and the captured image, the snow gauge at Site 2 (bare ground) detected the new snowfall almost immediately at 18:48.

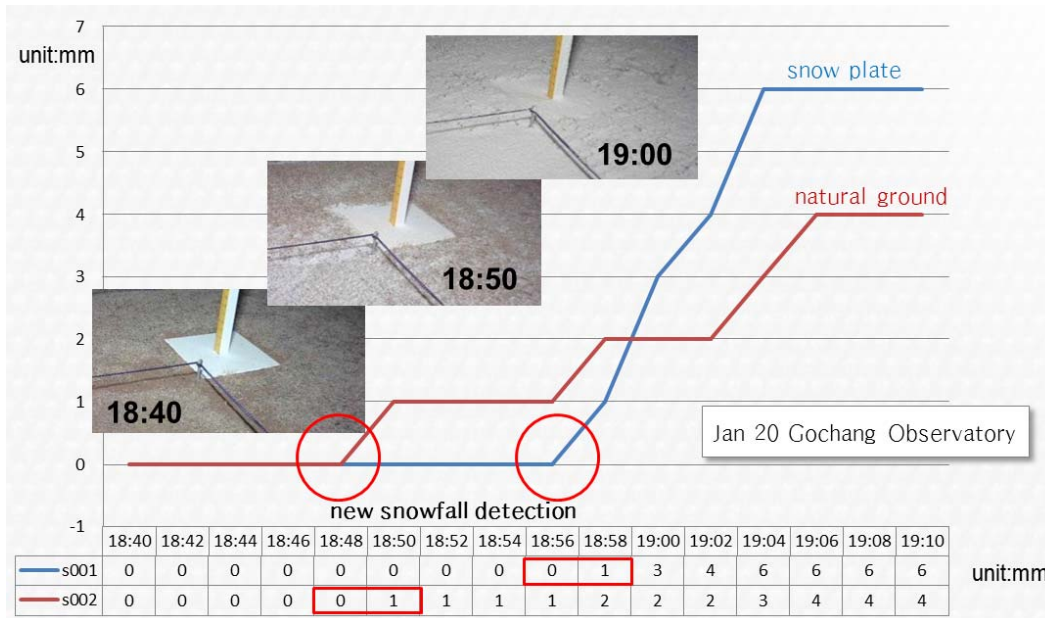

Figure 12 Detection of new snowfall with and without a snow plate

The snow plate used for Site 1 is a bright colored wooden plate, and we suspect that the signal reflected from the snow plate can be stronger than the signal reflected from the snowflakes especially at onset of new snowfall. When this happens, the distance measured by the gauge can be bigger than actual distance resulting in negative snow depth values at certain points affecting the final average. This phenomenon is depicted in Figure 13.

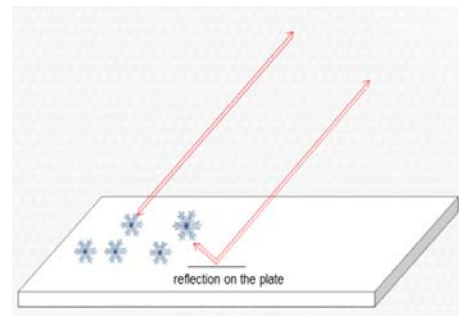

Figure 13 different reflection paths of measuring laser signal with a snow plate

As discussed in [1], most snow gauges can measure larger snow depths with adequate accuracy. But, they have difficulties in measuring small snow depths and detecting onset of snowfall. And, it's difficult to measure snow depth in millimeter accuracy because of various factors like size of snowflake and condition of the ground. But, even with consideration of these factors, the multipoint snow gauge was able to detect new snowfall as quickly enough as the snow depth reaches few mm.

(3) Additional snow fall detection (21 Jan, 2014) at site 3

Figure 14 shows additional snowfall at site 3 and 4 on top of existing snow of approximately 7 cm. We've used this event to evaluate performance of the snow gauge in detecting of new snowfall on top of existing snow. The snowfall was immediately detected and new precipitation was recorded properly. We believe there had been error no more than a couple of mm in detecting new snowfall in this case. This result is in line with the results of new snowfall detection performance with natural ground/earth.

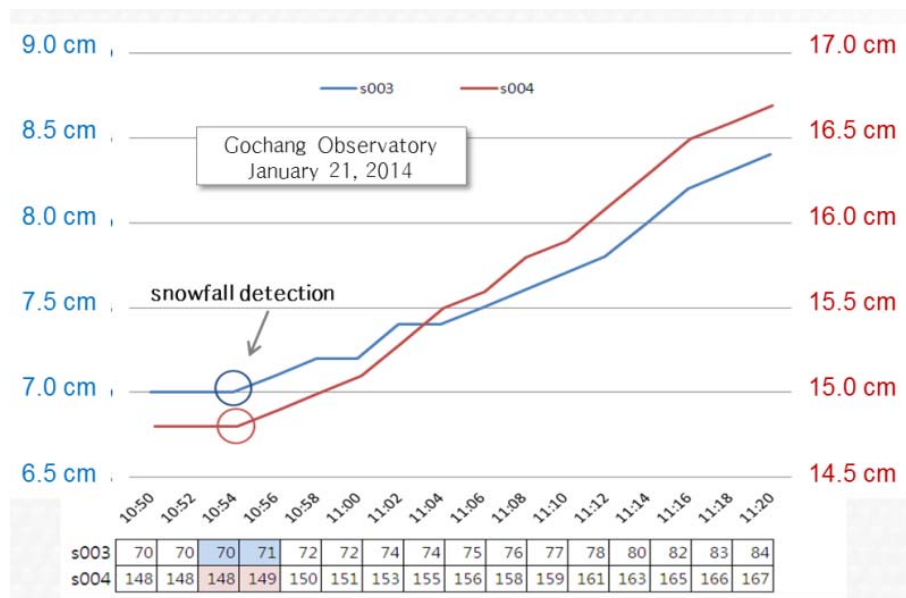

Figure 14

Snow Plates

Snow plates are commonly used to set the ground level for snow depth measurement. It's especially important when the measurements are done manually. Different snow plates are recommended to best emulate the natural ground level or grass in terms of keeping consistency in the depth of snow as snowfall accumulates or snow melts. Lanzinger and Theel presented design of snow grids and snow plates made of GRP optimized with respect to undisturbed deposition of snow, comparable to that on natural snow or grass surfaces [2]. One can hope that, at the end, an automatic snow gauge would be able to measure snow depth

on natural ground or grass without any snow plates. But, when automatic snow gauges are deployed in real fields, there are issues like growing weeds and change of the ground level due to frost or freezing. Therefore there are certain cases we need to have snow plates or grids even with multipoint scanning snow gauges which are less sensitive to the type of ground/earth.

Auto-zero Level Algorithm

There are other challenges in fully automatic generation of snow depth data of good quality in real fields. One of those challenges is to provide an effective auto-zero level function. Marijun de Haij mentioned that the distance to the zero level of the natural ground surface varies strongly in time. In certain cases, frost on the ground lifts the surface level under very cold conditions in the order of 1-2 cm. [3] This has been observed at all of our field test sites too.

We've developed auto-zero level algorithms and applied them to all the sites. Site 1 with a wooden snow plate has shown perfect performance with the auto-zero level calibration algorithms. Site 2 and 3 with natural ground/earth have shown acceptable auto-zero level performance as well. But, we had challenges with site 4 with grass because the zero level formed by the grass changes significantly in short time. When we changed parameters for the auto-zero level beyond certain thresholds, it lowered the sensitivity of new snowfall detection in certain cases.

V. SUMMARY

In this research, a multipoint laser snow depth gauge has been tested, and impacts of multipoint scanning to snow depth measurement have been analyzed and represented.

- As expected by many research work performed by different meteorological authorities, the multipoint scanning snow gauge scheme outperformed single point laser snow gauges and other types in terms of its accuracy and consistency.
- Test results have been compared with other measurements results at the site, and the results reasonably matched official manual measurement data and additional observation data by cameras.
- It's been observed that, when the multipoint scanning scheme is used, the accuracy/threshold of new snow fall detection can be as low as few millimeters.
- The new multipoint snow gauge solution didn't require significant cost increase when it's compared with single point laser snow gauges.
- The multipoint scanning scheme provides reasonable results at an inclination angle between 20° - 50° off the vertical line. This makes installation and operation of the gauge easier and more practical.
- Due to its multipoint nature, the multipoint scheme works well with natural ground with a proper auto-zero level function enabled.
- The multipoint scanning scheme enhanced the auto-zero capability in many cases.

ACKNOWLEDGEMENTS

This work was supported by the "Program for promotion of meteorological industry and development of application technologies" of Korea Meteorological Industry Promotion Agency (KMIPA) and Korea Meteorological Administration (KMA).

REFERENCES

- [1] Lanzinger, E. and Theel, M.: Improving reliability and sensitivity of a laser snow depth gauge. Presentation at TECO 2010, Helsinki, 30 August - 1 September 2010.

- [2] Lanzinger, E. and Theel, M.: Optimized snow plates and snow grids for automatic and manual snow depth measurements. Poster at TECO 2010, Helsinki, 30 August - 1 September 2010.
- [3] Marijun de Haij: Pre-operational field test of a laser snow depth sensor. Poster Presentation at TECO 2012, Brussels, Belgium, 16-18 October 2012.
- [4] Marijin de Haij: Field test of the Jenoptik SHM30 laser snow depth sensor. KNMI Technical Report; TR-325, De Bilt, December 2010 – June 2011