

INSTRUCTION MANUAL



IRGASON[®] Integrated CO₂/H₂O Open-Path Gas Analyzer and 3D Sonic[®] Anemometer

Revision: 10/13



Copyright © 2010-2013
Campbell Scientific, Inc.

Warranty

“PRODUCTS MANUFACTURED BY CAMPBELL SCIENTIFIC, INC. are warranted by Campbell Scientific, Inc. (“Campbell”) to be free from defects in materials and workmanship under normal use and service for twelve (12) months from date of shipment unless otherwise specified in the corresponding Campbell pricelist or product manual. Products not manufactured, but that are re-sold by Campbell, are warranted only to the limits extended by the original manufacturer. Batteries, fine-wire thermocouples, desiccant, and other consumables have no warranty. Campbell's obligation under this warranty is limited to repairing or replacing (at Campbell's option) defective products, which shall be the sole and exclusive remedy under this warranty. The customer shall assume all costs of removing, reinstalling, and shipping defective products to Campbell. Campbell will return such products by surface carrier prepaid within the continental United States of America. To all other locations, Campbell will return such products best way CIP (Port of Entry) INCOTERM® 2010, prepaid. This warranty shall not apply to any products which have been subjected to modification, misuse, neglect, improper service, accidents of nature, or shipping damage. This warranty is in lieu of all other warranties, expressed or implied. The warranty for installation services performed by Campbell such as programming to customer specifications, electrical connections to products manufactured by Campbell, and product specific training, is part of Campbell's product warranty. **CAMPBELL EXPRESSLY DISCLAIMS AND EXCLUDES ANY IMPLIED WARRANTIES OF MERCHANTABILITY OR FITNESS FOR A PARTICULAR PURPOSE.** Campbell is not liable for any special, indirect, incidental, and/or consequential damages.”

Assistance

Products may not be returned without prior authorization. The following contact information is for US and international customers residing in countries served by Campbell Scientific, Inc. directly. Affiliate companies handle repairs for customers within their territories. Please visit www.campbellsci.com to determine which Campbell Scientific company serves your country.

To obtain a Returned Materials Authorization (RMA), contact CAMPBELL SCIENTIFIC, INC., phone (435) 227-9000. After an applications engineer determines the nature of the problem, an RMA number will be issued. Please write this number clearly on the outside of the shipping container. Campbell Scientific's shipping address is:

CAMPBELL SCIENTIFIC, INC.

RMA# _____
815 West 1800 North
Logan, Utah 84321-1784

For all returns, the customer must fill out a "Statement of Product Cleanliness and Decontamination" form and comply with the requirements specified in it. The form is available from our web site at www.campbellsci.com/repair. A completed form must be either emailed to repair@campbellsci.com or faxed to (435) 227-9106. Campbell Scientific is unable to process any returns until we receive this form. If the form is not received within three days of product receipt or is incomplete, the product will be returned to the customer at the customer's expense. Campbell Scientific reserves the right to refuse service on products that were exposed to contaminants that may cause health or safety concerns for our employees.

Table of Contents

PDF viewers: These page numbers refer to the printed version of this document. Use the PDF reader bookmarks tab for links to specific sections.

1. Introduction	1
2. Cautionary Statements.....	1
3. Initial Inspection	2
4. Overview	2
5. Specifications	2
5.1 Measurements	2
5.2 Output Signals.....	5
5.3 Physical Description.....	5
5.4 Power Requirements During Power-up and Operation	7
6. Installation.....	7
6.1 Orientation	7
6.2 Mounting.....	7
6.3 Wiring and Connections.....	11
7. Settings.....	15
7.1 Factory Defaults	16
7.2 Bandwidth	16
7.3 SDM Address	16
7.4 Unprompted Output	17
7.5 Unprompted Output Rate	17
7.6 RS-485 Baud Rate.....	17
7.7 Analog Output.....	17
7.8 ECMon Update Rate	17
7.9 Temperature Sensor	17
7.10 Fixed Temperature Value.....	17
7.11 Pressure Sensor	18
7.11.1 Pressure Gain	18
7.11.2 Pressure Offset.....	18
7.11.3 Fixed Pressure Value	18
7.12 Pressure Differential Enable.....	18
7.13 Heater Control.....	18
7.14 ECMon.....	19
7.15 Device Configuration Utility.....	21

8. EC100 Outputs	22
8.1 SDM Output	22
8.2 USB or RS-485 Output.....	22
8.3 Analog Outputs.....	24
9. Maintenance	25
9.1 Routine Maintenance.....	25
9.2 Wick Maintenance.....	25
9.2.1 Sonic Wicks	25
9.2.2 Gas Analyzer Wicks.....	27
9.3 Gas-Analyzer Window Cleaning.....	28
9.4 Zero and Span.....	28
9.5 Replacing Desiccant and Scrubber Bottles.....	33
9.6 Factory Recalibration	34
10. Datalogger Programming	35
10.1 EC100() Instruction.....	35
10.2 EC100Configure() Instruction.....	38
10.2.1 <i>ConfigCmd 11</i> Zero-and-span Control	40
10.2.2 <i>ConfigCmd 18</i> Heater Voltage	40
10.3 Example CRBasic Program.....	41
11. Theory of Operation.....	42
11.1 IRGASON Sonic Anemometer	42
11.1.1 Wind Speed.....	42
11.1.2 Temperature	43
11.2 IRGASON Gas Analyzer	44
11.3 Theory References.....	45

Appendices

A. Filter Bandwidth and Time Delay.....	A-1
B. Equations.....	B-1
C. Material Safety Data Sheets (MSDS)	C-1
C.1 Magnesium Perchlorate MSDS	C-1
C.2 Decarbite MSDS.....	C-2

Figures

5-1. IRGASON dimensions, side view	6
5-2. IRGASON dimensions, front view.....	6
6-1. Exploded view of mounting the IRGASON	9
6-2. EC100-enclosure mounting bracket mounted on a vertical mast (left) and a tripod leg (right)	10
6-3. Exploded view of mounting the EC100 enclosure	10
6-4. Mounting the IRGASON Temperature Probe	11

6-5.	EC100 electronics front panel with enhanced barometer. At left, as received from Campbell Scientific. At right, all wiring and connections complete.	12
6-6.	Base of EC100 enclosure	13
6-7.	Sensor connections to EC100.....	13
7-1.	Main window of ECMon software.....	20
7-2.	Setup window in ECMon	21
8-1.	An example of USB data output in terminal mode	23
9-1.	Proper location of the sonic top wick (left) and bottom wick (right) ..	26
9-2.	PN 28902 CSAT3 Sonic Wick Spares Kit contents.....	27
9-3.	Proper location of the gas analyzer top wick (left) and bottom wick (right).....	28
9-4.	The zero-and-span shroud mounted on the zero-and-span stand. The top tube is the gas intake, the black cable is the temperature thermistor, and the short bottom tube is the gas exhaust.	30
9-5.	ECMon zero-and-span window.....	31
9-6.	Replacing the desiccant and CO2 scrubber bottles	34
A-1.	Frequency and amplitude response of EC100 filter at various bandwidths.....	A-2
A-2.	Frequency response comparison of the EC100 10 Hz bandwidth and a 50 ms moving average	A-3

Tables

6-1.	EC100 SDM Output to a Campbell Scientific CR1000, CR3000, or CR5000 Datalogger.....	14
7-1.	Factory Default Settings.....	16
8-1.	USB and RS-485 Output Elements	23
8-2.	Multipliers and Offsets for Analog Outputs.....	25
9-1.	Rain Wick Replacement Parts.....	27
10-1.	Output Modes for EC100 Instruction	36
10-2.	Bits in the Sonic Diagnostic Flag.....	36
10-3.	Bits in the Gas Diagnostic Flag.....	37
10-4.	<i>ConfigCmd</i> Values for Setting and Retrieving Settings	39
A-1.	Filter Time Delays for Various Bandwidths	A-3
B-1.	of Equation Variables and Constants	B-1

IRGASON[®] Integrated CO₂/H₂O Open-Path Gas Analyzer and 3D Sonic Anemometer

1. Introduction

The IRGASON, U.S. Des. Patent No. D680455, is an in-situ, open-path, mid-infrared absorption gas analyzer integrated with a three-dimensional sonic anemometer. The gas analyzer provides measurements of absolute densities of carbon dioxide and water vapor, while the sonic anemometer measures orthogonal wind components.

Before using the IRGASON please study:

- Section 2, *Cautionary Statements*
- Section 3, *Initial Inspection*
- Section 6, *Installation*

More details are available in the remaining sections.

2. Cautionary Statements

- **DANGER:**
 - The scrubber bottles (see Section 9.5, *Replacing Desiccant and Scrubber Bottles*) contain the strong oxidizing agents sodium hydroxide (caustic soda, NaOH) and anhydrous magnesium perchlorate (Mg(ClO₄)₂).
 - Avoid direct contact with the chemicals.
 - Ensure your work area is well ventilated and free of reactive compounds, including liquid water.
 - Store used chemical bottles in a sealed container until disposal.
 - Dispose of chemicals and bottles properly.
 - Materials Safety Data Sheets (MSDS) are provided in Appendix C. MSDS are updated periodically by chemical manufacturers. Obtain current MSDS at www.campbellsci.com.
- **WARNING:**
 - Do not carry the IRGASON by the arms or the strut between the arms. Always hold it by the block, where the upper and lower arms connect.
 - Handle the IRGASON carefully. The optical source may be damaged by rough handling, especially while the analyzer is powered.
 - Over-tightening bolts will damage or deform the mounting hardware.
- **CAUTION:**
 - Grounding the EC100 measurement electronics is critical. Proper grounding to earth (chassis) will ensure maximum ESD (electrostatic discharge) protection and improve measurement accuracy.

- Do not connect or disconnect the gas analyzer or sonic connectors while the EC100 is powered.
- The SDM, USB, and RS-485 output options include IRGASON diagnostic data. Be aware that the absence of diagnostic data in the analog output option could make troubleshooting difficult and may lead to the user not being aware of potential problems with the instrumentation (see Section 8, *EC100 Outputs*).
- Resting the analyzer on its side during the zero-and-span procedure may result in measurement inaccuracy.
- When cleaning the gas-analyzer window, make sure the alcohol and any residual water completely evaporate before proceeding with the zero-and-span procedure (see Section 9.3, *Gas-Analyzer Window Cleaning*).

3. Initial Inspection

Upon receipt of the IRGASON, inspect the packaging and contents for damage. File damage claims with the shipping company.

4. Overview

The IRGASON is an in-situ, open-path, mid-infrared absorption analyzer integrated with a three-dimensional sonic anemometer. The gas analyzer provides measurements of absolute densities of carbon dioxide and water vapor, while the sonic anemometer measures orthogonal wind components.

The IRGASON is measured and controlled by the EC100 electronics, which synchronizes gas and wind data, essential for valid flux calculations using the eddy-covariance method. The EC100 electronics also uses inputs from an included temperature thermistor probe and a barometer. “IRGASON” and “EC100” are often used interchangeably in this manual.

The IRGASON has been optimized for remote eddy-covariance- flux applications, addressing issues of aerodynamics, power consumption, spatial displacement, and temporal synchronicity. Specifically, its unique design contains no obstructions surrounding the sample volume; it operates with only 5 Watts of power at room temperature; it has no spatial displacement between the sample volumes of the gas analyzer and the sonic anemometer; and the EC100 synchronously samples data from the gas analyzer and sonic anemometer.

5. Specifications

5.1 Measurements

Features

- To compute carbon dioxide and water vapor fluxes using the eddy-covariance method, the IRGASON measures:
 - absolute carbon dioxide
 - water vapor densities
 - three-dimensional wind speed
 - sonic air temperature
 - air temperature
 - barometric pressure

These measurements are required to compute carbon dioxide and water vapor fluxes using the:

- Standard outputs:
 - u_x, u_y, and u_z orthogonal wind components
 - sonic temperature (based on the measurement of c, the speed of sound)
 - sonic diagnostic flags
 - CO₂ density, H₂O density
 - gas analyzer diagnostic flags
 - air temperature, air pressure
 - CO₂ signal strength, H₂O signal strength
 - Air temperature and air pressure are auxiliary sensor inputs

Datalogger compatibility: CR1000
CR3000
CR5000

Measurement

Rate: 100 Hz
Output bandwidth²: 5, 10, 12.5, 20, or 25 Hz
Output rate²: 10, 25 or 50 Hz

Operating temperature: -30° to 50°C

Gas analyzer

Measurement precision¹

CO₂ density: 0.2 mg·m⁻³ (0.15 μmol·mol⁻¹)
H₂O density: 0.00350 g·m⁻³ (0.006 mmol·mol⁻¹)

Factory calibrated range

CO₂: 0 to 1000 μmol·mol⁻¹
H₂O: 0 mmol·mol⁻¹ to 37°C dewpoint
Analyzer temp: -30° to 50°C
Baro pressure: 70 to 106 kPa

CO₂ performance

Zero max drift³: ±0.55 mg·m⁻³·°C⁻¹ (±0.3 μmol·mol⁻¹·°C⁻¹)
Gain Drift: ±0.1% of reading·°C⁻¹ (maximum)
Sensitivity to H₂O: ±1.1 x 10⁻⁴ μmol CO₂·mol⁻¹ H₂O (max)

H₂O performance

Zero max drift³: ±0.037 g·m⁻³·°C⁻¹ (±0.05 mmol·mol⁻¹·°C⁻¹)
Gain Drift: ±0.3% of reading·°C⁻¹ (maximum)
Sensitivity to CO₂: ±0.1 mol H₂O·mol⁻¹ CO₂ (maximum)

Sonic measurement precision⁴

u_x: 1 mm·s⁻¹
u_y: 1 mm·s⁻¹
u_z: 0.5 mm·s⁻¹
Sonic temperature: 0.025°C

Sonic accuracy⁵

Offset error

u_x, u_y: < ±8 cm·s⁻¹
u_z: < 4 cm·s⁻¹

Gain error

Wind vector ±5° horizontal: < ±2% of reading
Wind vector ±10° horizontal: < ±3% of reading
Wind vector ±20° horizontal: < ±6% of reading

Sonic reporting range

Full scale wind: ±65.553 m/s
Sonic temperature: -50° to +60°C

Auxiliary sensors⁶

Barometer

Basic barometer

Accuracy

-30 to 0°C: ±3.7 kPa at -30°C, falling linearly to ±1.5 kPa at 0°C

0° to 50°C: ±1.5 kPa

Measurement rate: 10 Hz

Optional enhanced barometer:

Manufacturer: Vaisala

Model: PTB110

Accuracy

-30 to 0°C: ±0.15 kPa

Measurement rate: 1 Hz

IRGASON temperature sensor:

Manufacturer: BetaTherm

Model: 100K6A1A Thermistor

Accuracy: ±0.15°C (-30° to 50°C)

¹ noise rms, assumes:

- 25°C
- 85 kPa
- 14 g·m⁻³ H₂O
- 597 mg·m⁻³ CO₂
- 25 Hz bandwidth.

² user selectable

³ -30° to 50°C

⁴ noise rms

⁵ assumes:

- -30° to +50°C
- wind speed <30 m·s⁻¹
- azimuth angles between ±170°

⁶ refer to manufacturer's product brochure or manual for details

5.2 Output Signals

Features

- EC100 electronics outputs data using:
 - CS SDM
 - RS-485
 - USB
 - Analog out

Digital

SDM (Synchronous Device for Measurement)¹

Data type: FLOAT

RS-485

Data type: ASCII

Output Rate: 5 to 50 Hz

Baud rate: 1200 to 230400 bps

USB

Data type: ASCII

Output rate: 10, 25 or 50 Hz

Analog (two outputs for CO₂ and H₂O densities)

Voltage range: 0 mV to 5000 mV

Resolution: 76 μV (16 bit)

Update rate: 100 Hz

Accuracy (at 25°C): ±3 mV

CO₂ density equation: $\text{mg}\cdot\text{m}^{-3} = 0.38632 \cdot (\text{mV}_{\text{out}}) - 102.59$

Full scale range: -103 to 1829 mg·m⁻³

H₂O density equation: $\text{g}\cdot\text{m}^{-3} = 0.00865 \cdot (\text{mV}_{\text{out}}) - 2.26$

Full scale range: -2 to 41 g·m⁻³

¹ Synchronous Device for Measurement. A Campbell Scientific, Inc. proprietary serial interface for datalogger to peripheral and sensor communication. See Section 8.1, *SDM Output* for details.

² user selectable

5.3 Physical Description

Optical path length: 15.37 cm (6.05 in)

Sonic path length: 10.0 cm

Sonic path angle from vertical: 30°

Spatial separation between gas analyzer and sonic volumes: 0 cm

Dimensions

IRGASON

Length: 51.5 cm (20.3 in)

Height: 31.1 cm (12.2 in)

Cable Length: 3 m (9.8 ft)

EC100 Enclosure: 24.1 x 35.6 x 14 cm (9.5 x 14.0 x 5.5 in)

Weight

IRGASON with Cable: 2.8 kg (6.1 lbs)

EC100 with Enclosure: 3.2 kg (7 lbs)

5.4 Power Requirements During Power-up and Operation

Power requirement	
Source:	10 to 16 Vdc
Load	
at 25°C:	420 mA
at 25°C in power-down mode¹:	250 mA

¹ sonic anemometer fully powered and gas analyzer in stand-by

6. Installation

6.1 Orientation

During operation, the IRGASON should be leveled and pointed into the prevailing wind to minimize flow distortions from the instrument arms and other supporting structures. Leveling can be done using the leveling bubble on top of the instrument block. In the proper orientation, the product label will read right-side-up, with the upper arm (source) of the gas analyzer directly above the lower arm (detector).

6.2 Mounting

The IRGASON is supplied with mounting hardware to attach it to the end of a horizontal pipe with a diameter of 1.31 in., such as the Campbell Scientific CM202, CM204, or CM206 crossarm. The following steps describe the normal mounting procedure. Refer to FIGURE 6-1.

1. Secure the chosen crossarm to a tripod or other vertical structure using a CM210 Crossarm-to-Pole Mounting Kit (pn 17767).
2. Point the horizontal arm into the direction of the prevailing wind and tighten the nuts and bolts.

WARNING

Do not carry the IRGASON by the arms or the strut between the arms. Always hold it by the block, where the upper and lower arms connect.

3. Bolt the IRGASON mounting bracket (pn 27496) to the CM250 Leveling Mount (pn 26559) (see FIGURE 6-1).
4. Install the IRGASON to the mounting bracket by inserting the mounting bolt and pin into the corresponding holes. Tighten the bolt. Make sure the analyzer is vertically oriented so the label is right-side-up and the upper arm (source) is directly above the lower arm (detector).
5. Mount the IRGASON assembly by fitting the boom adapter over the end of the crossarm. Tighten the set screws on the boom adapter with a 3/16 inch hex socket head wrench.

WARNING

Handle the IRGASON carefully. The optical source may be damaged by rough handling, especially while the analyzer is powered.

6. If the assembly is not level, slightly loosen the bolt that holds the mounting bracket on the boom adapter and adjust the assembly until the leveling bubble on top of the IRGASON block is within the bullseye. Retighten the bolt.

7. Attach the EC100 enclosure to the mast, tripod leg, or other part of the mounting structure. To do this, attach the EC100-enclosure mounting bracket (pn 26604) to the pipe by loosely tightening the u-bolts around the pipe. The u-bolts are found in the mesh pocket inside the EC100 enclosure. If the pipe does not run vertically (for example, if the enclosure is being attached to a leg of a tripod), rotate the bracket to the side of the pipe. The enclosure must hang upright. Make angle adjustments as needed by loosening the four nuts and rotating the bracket plates relative to one another. If the necessary angle cannot be achieved in the given orientation, the four nuts may be removed and the top plate indexed by 90° to allow the bracket to travel in the other direction (see FIGURE 6-2). Once adjusted, tighten all the nuts. Finally, attach the EC100 enclosure to the bracket by loosening the bolts on the back of the enclosure, hanging the enclosure on the mounting bracket (it should slide into place and be able to securely hang from the bracket), and tightening the bolts (see FIGURE 6-3).

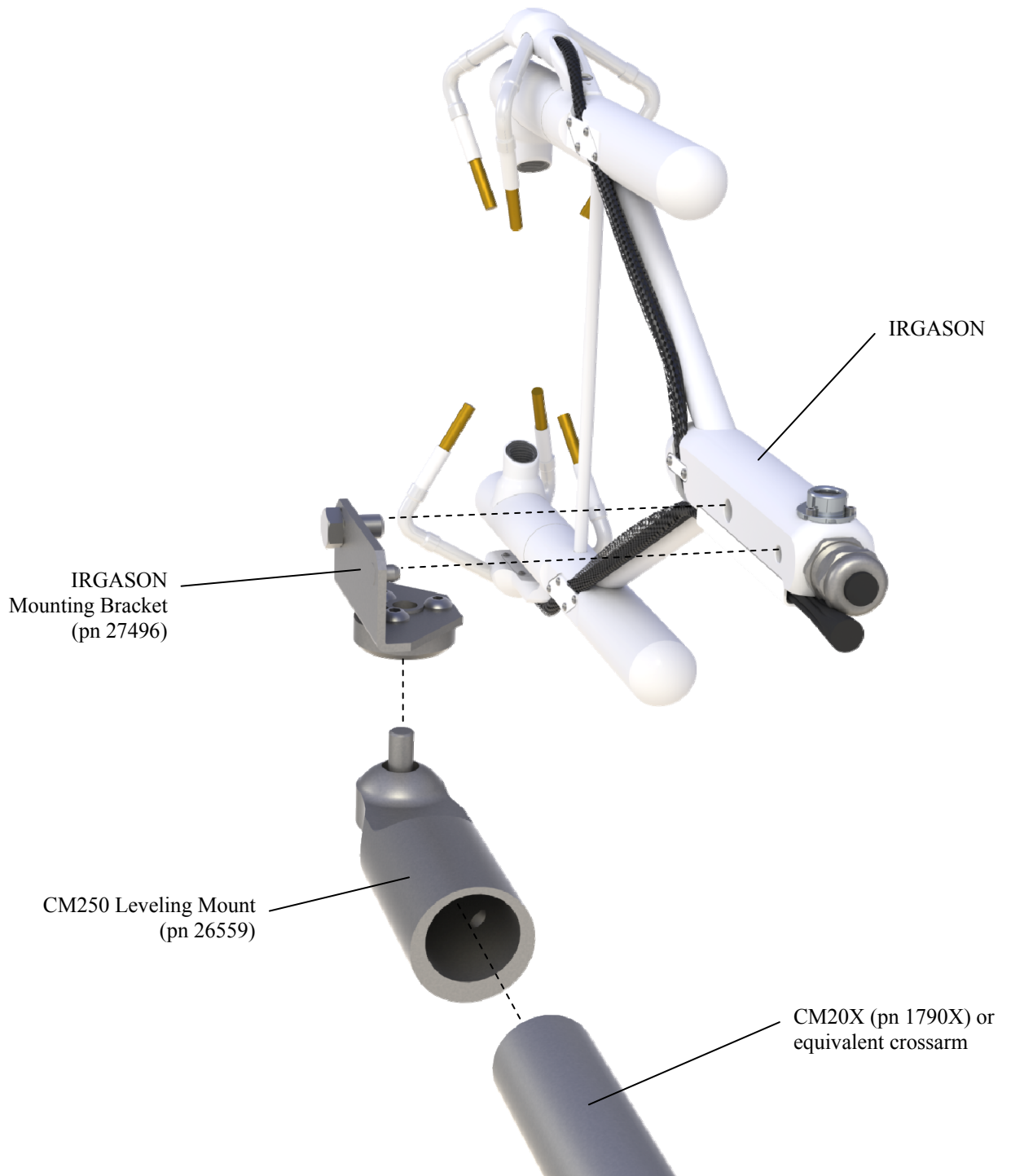

FIGURE 6-1. Exploded view of mounting the IRGASON

WARNING

Over-tightening bolts will damage or deform the mounting hardware.

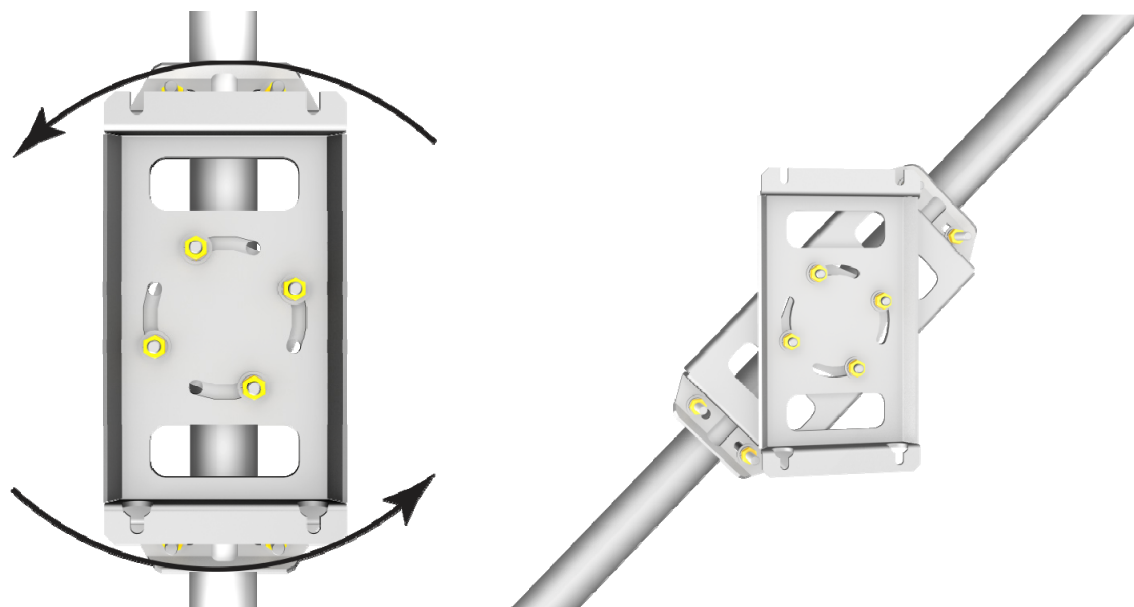

FIGURE 6-2. EC100-enclosure mounting bracket mounted on a vertical mast (left) and a tripod leg (right)

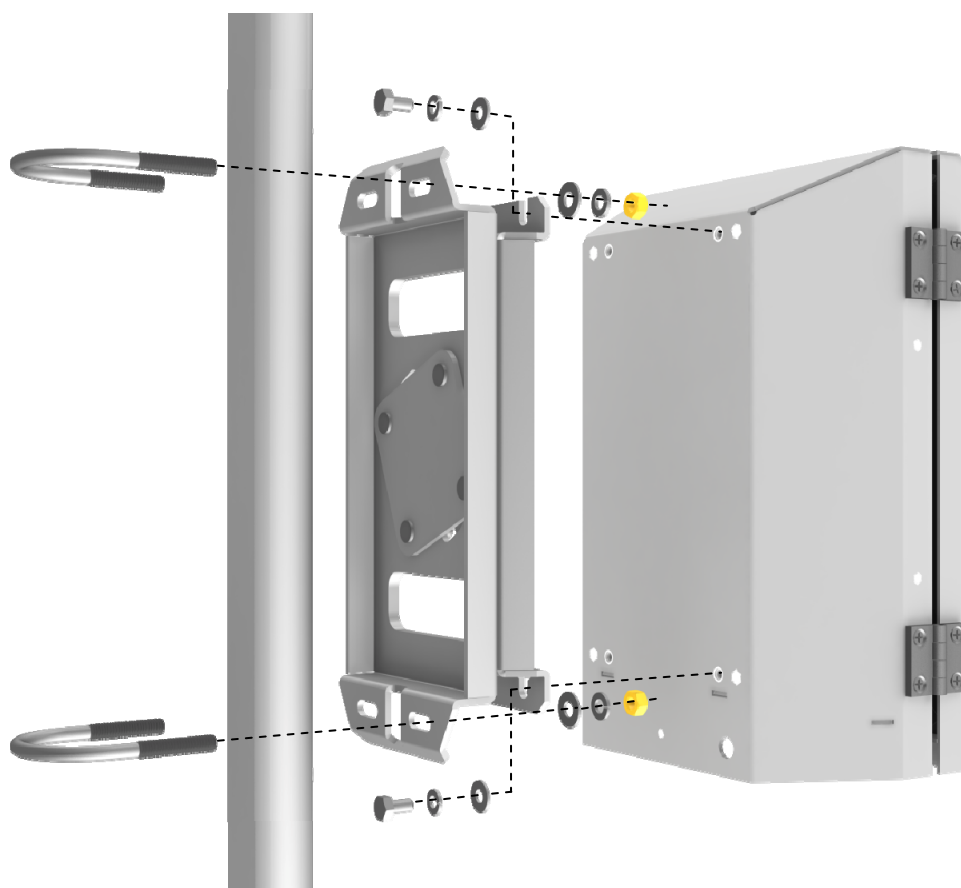

FIGURE 6-3. Exploded view of mounting the EC100 enclosure

8. Mount the IRGASON temperature probe so that it measures temperature at the same height as the sample volume of the IRGASON. To do this, first attach the R.M. Young 41303-5A 6-Plate Solar Radiation Shield (pn 4020) to the mast with the included u-bolt. Next, insert the end of the probe into the hole on the bottom of the shield. Tighten the screws to hold the probe in place. See FIGURE 6-4. For more detailed information about the temperature probe installation and specifications, refer to the *Model 107 Temperature Probe* manual, which is available at www.campbellsci.com.
9. Remove the EC100- enclosure desiccant from the plastic bag and place it in the mesh pocket of the enclosure. Attach the humidity indicator card to the inside of the enclosure.

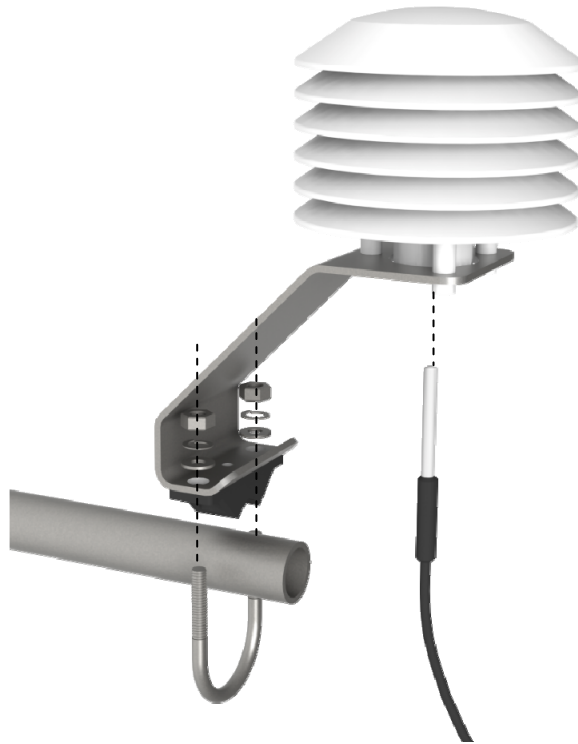

FIGURE 6-4. Mounting the IRGASON Temperature Probe

6.3 Wiring and Connections

FIGURE 6-5, FIGURE 6-6, and FIGURE 6-7 show the EC100 electronics panel, the bottom of the EC100 enclosure, and sensor connections to the EC100, respectively. Refer to these figures during wiring and connecting.

1. Find the thicker black cable coming from the block of the IRGASON. This is the IRGASON gas-analyzer cable. Connect this cable to the EC100 electronics by removing the black-rubber cable entry plug (pn 26224) on the bottom right of the EC100 enclosure. (This plug can be stored in the mesh pocket of the enclosure). Next, insert the cable entry plug that is attached to the cable into the vacant slot. Push the connector at the end of the cable onto its mating connector (labeled *Gas Analyzer*) and

tighten the thumbscrews (see FIGURE 6-5). The gas analyzer cable is approximately 3 meters in length.

2. Connect the IRGASON sonic cable. Similar to (a), begin by removing the black- rubber cable-entry plug found on the bottom left of the EC100 enclosure. Insert the cable entry plug on the cable into the slot and connect the male end to the female connector labeled *Sonic Anemometer* on the EC100 electronics (see FIGURE 6-5). The sonic cable is approximately 3 meters in length.

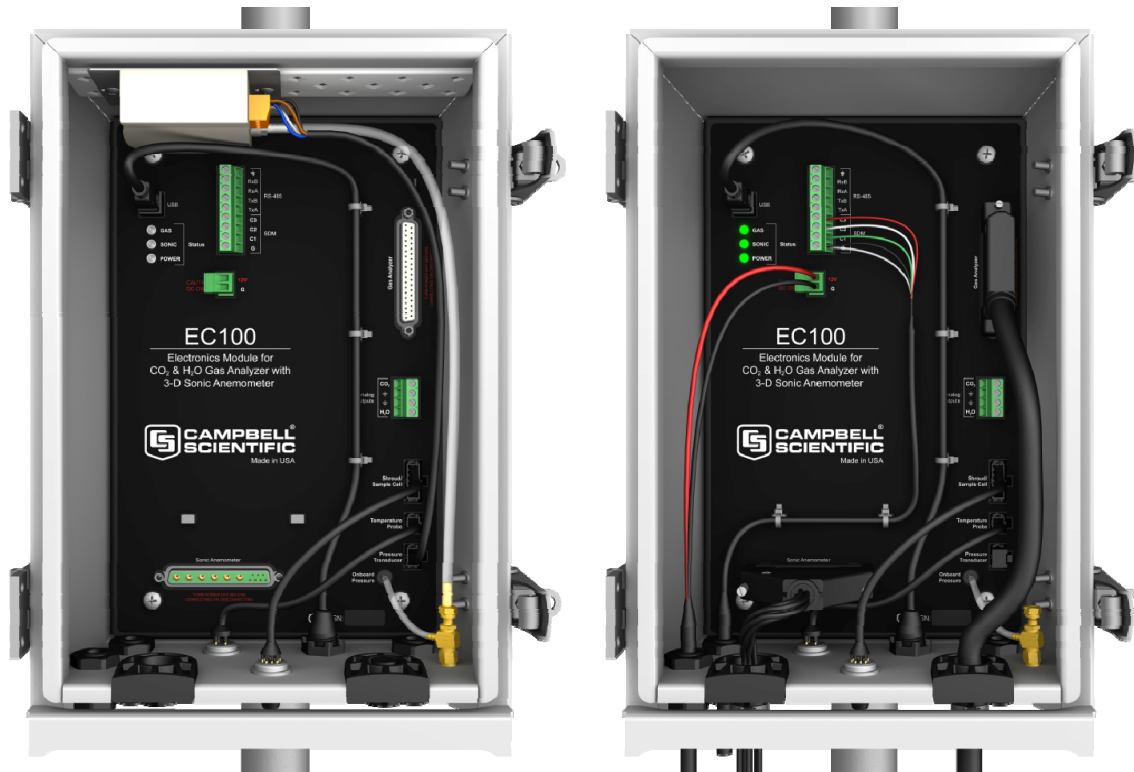

FIGURE 6-5. EC100 electronics front panel with enhanced barometer. At left, as received from Campbell Scientific. At right, all wiring and connections complete.

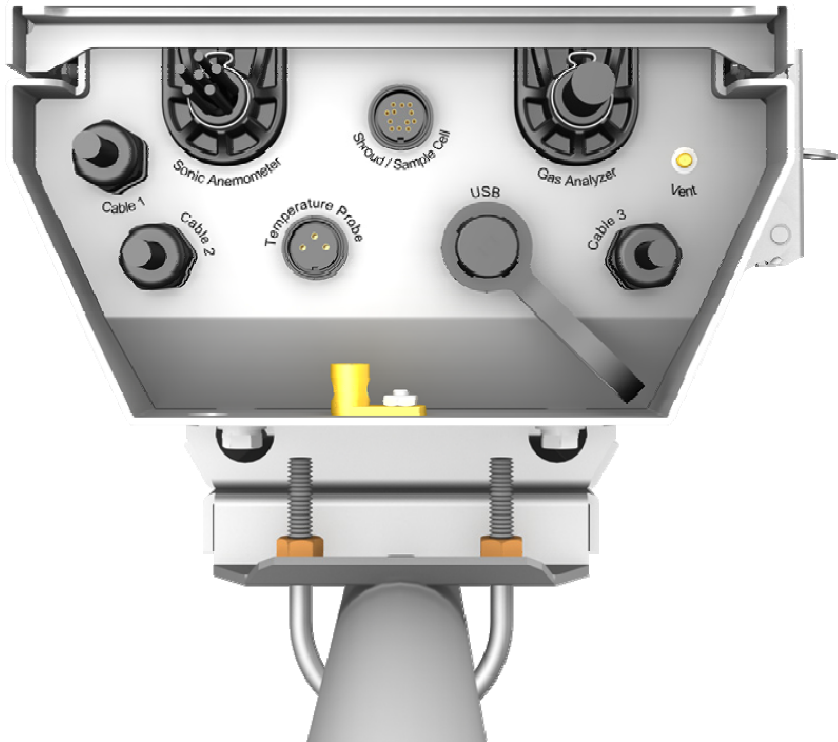

FIGURE 6-6. Base of EC100 enclosure

NOTE

Unique calibration information is stored in the gas and sonic connectors of the IRGASON rather than in the EC100. This means that any IRGASON may be used with any EC100.



FIGURE 6-7. Sensor connections to EC100

3. Connect the IRGASON temperature probe. Unscrew the temperature connector cover, which is found on the base of the EC100 enclosure (see FIGURE 6-6). Insert the 3-prong probe connector into the female connector on the enclosure and screw it firmly in place. The IRGASON temperature probe cable is approximately 3 meters in length.
4. Ground the EC100 by attaching a thick wire (e.g., 12 AWG) to the grounding lug found on the base of the EC100 enclosure. The other end of the wire should be connected to earth (chassis) ground using a grounding rod. For more details on grounding, see the CR3000 datalogger manual, grounding section.

CAUTION Grounding electronics such as the EC100 is critical in a measurement system. Proper grounding to earth (chassis) will ensure maximum ESD (electrostatic discharge) protection and improve measurement accuracy.

CAUTION Do not connect or disconnect the gas analyzer or sonic connectors while the EC100 is powered.

5. Connect a communications signal cable to the EC100. Loosen the nut on one of the cable entry seals (Cable 1 or Cable 2) on the base of the EC100 enclosure, remove the plastic plug (plug may be stored in mesh pocket of enclosure), insert the cable, and retighten the nut by hand. Refer to the sections below on SDM, USB, RS-485, and Analog communications for information on required signal cable types and connections to the EC100 panel.
 - SDM communications: Use cable CABLE4CBL-L (pn 21972). “L” denotes the length of the cable, which is customer-specified at time of order. TABLE 6-1 details which color of wire in the cable should be connected to each terminal found on the SDM connector of the EC100 panel.

TABLE 6-1. EC100 SDM Output to a Campbell Scientific CR1000, CR3000, or CR5000 Datalogger

EC100 Channel	Description	Color
SDM-C1	SDM Data	Green
SDM-C2	SDM Clock	White
SDM-C3	SDM Enable	Red (or Brown)
G	Digital Ground	Black
G	Shield	Clear

- USB communications: Use the EC100 USB cable (pn 26561) to connect a PC to the base of the EC100 enclosure.
- RS-485 communications: use cable CABLE3TP-L (pn 26987) for lengths less than 500 ft. The connector on the EC100 panel labeled RS-485 displays which terminals are for receiving and transmitting.

- Analog output: use cable CABLE4CBL-L (pn 21972) or CABLE2TP-L (pn 26986-L). Once again, the customer specifies the length of this cable at time of order. The connector labeled *Analog Outputs* on the EC100 panel indicates where each wire should be connected (CO₂ voltage signal, H₂O voltage signal, and two ground connections).
6. Wire power and ground (i.e., power reference) cable CABLEPCBL-L (pn 21969-L) to the EC100. Feed the cable through one of the cable port openings in the base of the EC100 enclosure and attach the ends into the green EC100 power connector (pn 3768). Plug the connector into the female power connector on the EC100 panel. Ensure that the power and ground ends are going to the appropriate terminals labeled 12V and ground, respectively.
 7. Connect the power cable to a power source. The power and ground ends may be wired to the 12V and G ports, respectively, of a Campbell Scientific datalogger or to another 12 Vdc source.
 8. Once power is applied to the EC100, three status LEDs on the EC100 panel will illuminate. The power LED is green and the sonic and gas LEDs are orange until the unit has warmed up and is ready to make measurements at which time the LEDs become green. If, after several minutes, the LEDs turn red, a diagnostic flag has been detected. Check the individual diagnostic bits to determine the specific fault. Diagnostics may be monitored using the Status Window of ECMon, the user interface software included with the IRGASON (see Section 7, *Settings*), or with a datalogger (see Section 10, *Datalogger Programming*). The diagnostics may reveal that the unit needs service such as cleaning the optical windows on the gas analyzer, clear the sonic transducers of ice or debris, etc. (see Section 9, *Maintenance*).

7. Settings

Operation of the IRGASON can be customized by changing settings. Factory defaults work well for most applications, but the user may adjust the settings with a PC using either the Campbell Scientific ECMon software (see Section 7.14, *ECMon*) or DevConfig (see Section 7.15, *Device Configuration Utility*), or with a datalogger using the **EC100Configure()** instruction (see Section 10.2, *EC100Configure() Instruction*).

7.1 Factory Defaults

TABLE 7-1 shows the default value for each setting described in the following sections.

TABLE 7-1. Factory Default Settings	
Bandwidth	20 Hz
SDM Address	1
Unprompted Output	disabled
RS-485 baud rate	115200 bps
Unprompted Output Rate	10 Hz
Analog Output	disabled
ECMon Update Rate	10 Hz
Temperature Sensor	Auto-Select (IRGASON Temp Sensor)
Pressure Sensor	EC100 Basic or EC100 Enhanced (depending on order)
Pressure Differential Enable	Auto-Select (Disabled for IRGASON)
Heater Control	Disabled

7.2 Bandwidth

The EC100 has a user-selectable low-pass filter to select the bandwidth (5, 10, 12.5, 20, or 25 Hz). Setting the bandwidth to a lower value will reduce noise. However, it must be set high enough to retain the high-frequency fluctuations in CO₂ and H₂O, or else the high frequency contributions to the flux will be lost. The factory default bandwidth of the EC100 is 20 Hz, which is sufficient for most flux applications. Lower bandwidth settings may be used for higher measurement heights, which inherently have lower-frequency content. Refer to Appendix A, *Filter Bandwidth and Time Delay* for more information on the digital filter options.

If a spectral analysis is being done to evaluate the experimental setup, the bandwidth should be set to the Nyquist frequency, which is half the datalogger sample rate (for SDM output) or half the unprompted output rate (for USB and RS-485 output). This ensures that the data will not be under-sampled and that higher-frequency variations will not be aliased to lower frequencies. Note that if too small a bandwidth is selected, high-frequency fluxes may be under-measured.

7.3 SDM Address

This parameter must be set to use SDM output from the EC100. See Section 8.1, *SDM Output* for details on using SDM output.

Each SDM device on the SDM bus must have a unique address. The IRGASON has a factory default SDM address of 1, but it may be changed to

any integer value between 0 and 14. The value 15 is reserved as an SDM-group trigger.

7.4 Unprompted Output

If the EC100 is to output data as USB or RS-485 (see Section 8.2, *USB or RS-485 Output*), this setting must be set to **USB Port** or **RS485**, respectively. The factory default is to disable the unprompted output and assume data are to be logged via SDM (see Section 8.1, *SDM Output*).

Only one unprompted-output type (i.e., USB or RS-485) may be selected at a given time. The rate at which the EC100 outputs these data is determined by the **Unprompted Output Rate** setting.

7.5 Unprompted Output Rate

This setting determines the output rate for unprompted output (USB or RS-485; see Section 8.2, *USB or RS-485 Output*). If the unprompted output is disabled, this parameter is not used. The factory-default output rate is 10 Hz, but it may be set to 10, 25, or 50 Hz.

7.6 RS-485 Baud Rate

If the unprompted output mode is set to RS-485, this parameter determines the baud rate. Otherwise, this setting is not used. The RS-485 baud rate defaults to 115200 bps, although the user may enter another value.

7.7 Analog Output

The EC100 has two analog outputs for CO₂ and H₂O densities (see Section 8.3, *Analog Outputs* for more information). These outputs may be enabled or disabled with this setting. The default is for analog output to be disabled. Note that the analog output does not include sonic data.

7.8 ECMon Update Rate

This setting determines the rate at which data are sent over the USB connection to the PC while running ECMon. The default setting of 10 Hz should be adequate in most situations.

7.9 Temperature Sensor

This setting configures the EC100 electronics to integrate with the IRGASON. The IRGASON measures ambient air temperature using a thermistor temperature sensor. With **Auto-Select** selected, the EC100 will detect that the IRGASON is connected and will report ambient air temperature measurements from the thermistor.

To diagnose problems with the temperature measurement, a fixed temperature value may be used, or the temperature sensor may be selected manually.

7.10 Fixed Temperature Value

If the **Temperature Sensor** setting is **None**, the IRGASON will use the value of this setting for the sample temperature. This mode is intended for

troubleshooting only. In normal operation, **Temperature Sensor** is set to **Auto-Select**, and this setting is not used.

7.11 Pressure Sensor

This setting identifies which barometric pressure sensor is used. The EC100 always includes the basic barometer, but it may be ordered with the optional enhanced barometer (model CS106). This setting defaults to **EC100 Enhanced** if the CS106 is ordered and to **EC100 Basic** otherwise.

There are two other possible settings for **Pressure Sensor**. First, the user may supply a different pressure sensor. In this case, the setting should be changed to **User Supplied**, with the appropriate values for gain and offset entered (see below).

The final option is to select **None** for **Pressure Sensor**. The EC100 will use a fixed (see below) value for pressure. This mode is intended for troubleshooting only.

7.11.1 Pressure Gain

If **Pressure Sensor** is set to **User Supplied**, this setting gives the gain factor (kPa/V) used to convert measured voltage to pressure. Normally, **Pressure Sensor** is set to **EC100 Basic** or **EC100 Enhanced**, and this setting is not used.

7.11.2 Pressure Offset

If **Pressure Sensor** is set to **User Supplied**, this setting gives the offset (kPa) used to convert measured voltage to pressure. Normally, **Pressure Sensor** is set to **EC100 Basic** or **EC100 Enhanced**, and this setting is not used.

7.11.3 Fixed Pressure Value

If **Pressure Sensor** is **None**, the EC100 will use the value of this setting for the barometric pressure. This mode is intended for troubleshooting only. In normal operation, this setting is not used.

7.12 Pressure Differential Enable

This setting should remain disabled. It is used only for closed-path analyzers.

7.13 Heater Control

When enabled, this setting applies a voltage between 0 and 4500 mV to heaters near the optical windows of the analyzer. Heated windows inhibit the formation of condensation, such as dew and frost, and help the analyzer recover more quickly when precipitation has blocked the optical path. Use this setting with caution. Excessive heating may lead to density fluctuations and subsequent flux measurement errors. More information about heater control, and specifically using a datalogger for control, may be found at the end of Section 10.2, *EC100Configure() Instruction*.

7.14 ECMon

Settings for the IRGASON are easily verified or changed using the Windows PC support software ECMon (**E**ddy **C**ovariance **M**onitor), which is found on the *IRGASON, EC150 & EC155 Support CD* (pn 27007) or at www.campbellsci.com.

Before installing ECMon, read the file titled *_Read_me.txt* found on the *IRGASON, EC150 & EC155 Support CD*. This file directs the user to install USB drivers (also found on the support CD), which are required for communications between the PC and the EC100 via the EC100 USB cable (pn 26561). Some newer PC operating systems will automatically find and download the USB drivers from the internet when the USB cable is connected to the PC. Once the drivers are installed, download and run the ECMon.exe install file. Launch ECMon, and connect the EC100 electronics to the PC with the included EC100 USB cable (pn 26561). The USB connection for the EC100 electronics is found on the base of the enclosure (see FIGURE 6-7). Once connected, select the appropriate communications port in the ECMon main page and click **Connect** (see FIGURE 7-1). Next, click on the **Setup** button. All of the preceding settings are now available for editing (see FIGURE 7-2).

Besides changing settings, ECMon is a useful tool for common tasks such as:

- Monitoring real-time data from the IRGASON from the main window
- Performing manual zero and span of the instrument (see Section 9.4, *Zero and Span*)
- Troubleshooting and monitoring diagnostics using the **Status** window.

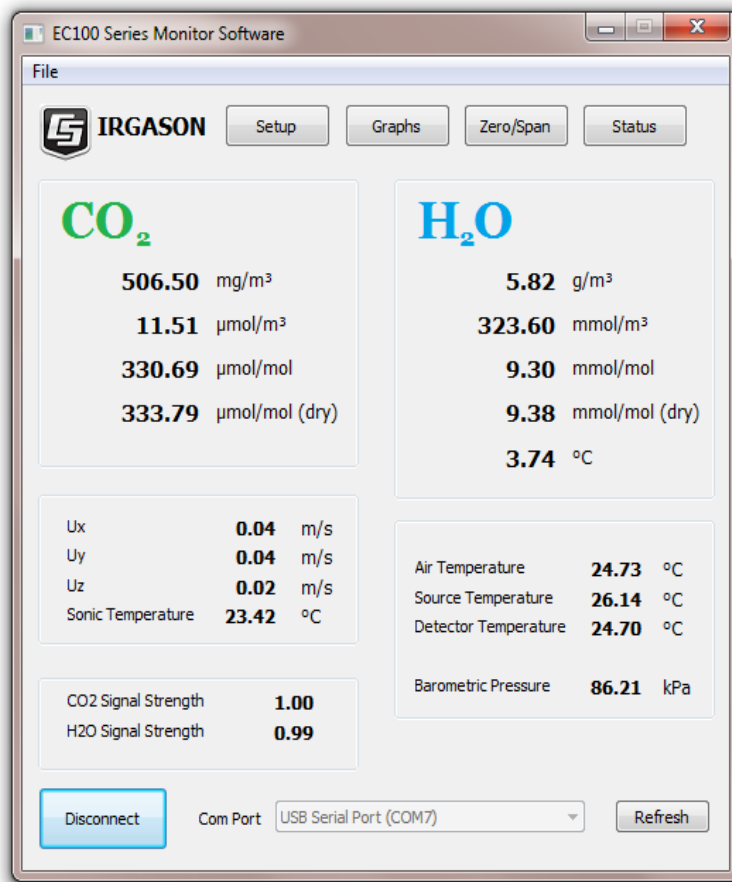

FIGURE 7-1. Main window of ECMon software

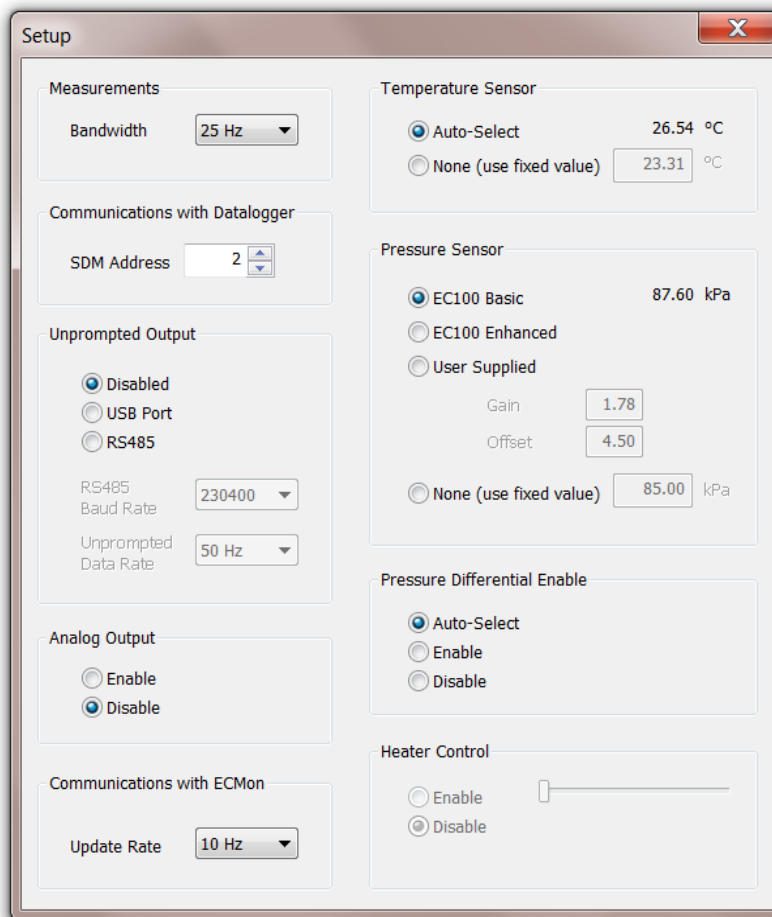

FIGURE 7-2. Setup window in ECMon

7.15 Device Configuration Utility

DevConfig software (**Device Configuration Utility**) may also be used to change settings, although ECMon is generally preferred because of its more user-friendly interface. DevConfig may be downloaded from the *IRGASON, EC150 & EC155 Support CD* (pn 27007), or may be downloaded free of charge from the Campbell Scientific website www.campbellsci.com. DevConfig requires a USB driver to communicate with the EC100, similar to ECMon. See Section 7.14, *ECMon* for notes on installing a USB driver.

After launching DevConfig, select “EC100” from the list of device types. The EC100 electronics should be connected to the PC with the EC100 USB cable (pn 26561) and the appropriate USB port selected before connecting. Once connected, the settings tab displays all the current settings. The **Apply** button must be clicked to save any changes.

DevConfig is also used to send an updated operating system to the EC100 electronics. The **Send OS** tab gives directions on this procedure.

8. EC100 Outputs

The EC100 is the IRGASON electronics module that measures the sensors and controls the system. It outputs data in one of four types: SDM, USB, RS-485, or analog. In general, Campbell Scientific recommends that SDM be used if a Campbell Scientific datalogger is responsible for data collection. However, RS-485 output is recommended if cable lengths exceed 100 meters. If a PC is being used as the collection vehicle, USB and RS-485 are suitable outputs. Analog output may also be used; however, only CO₂ density and H₂O density will be output. Information regarding each output type is provided in the following sections.

8.1 SDM Output

SDM (Synchronous Device for Measurement) is a proprietary Campbell Scientific communication protocol that allows synchronized measurement and rapid communication between a Campbell Scientific datalogger and multiple devices, including the IRGASON. Although nearly all Campbell Scientific dataloggers support SDM, only the CR1000, CR3000, and CR5000 dataloggers support the IRGASON.

To use SDM data output, connect an SDM-communications cable from the EC100 (see Section 6.3, *Wiring and Connections*) to a CR1000, CR3000, or CR5000 datalogger. On CR1000 dataloggers, the SDM protocol uses ports C1, C2, and C3. These are multipurpose ports that are SDM-activated when an SDM instruction is used in the datalogger's program. On CR3000 and CR5000 dataloggers, the SDM protocol uses SDM-dedicated ports SDM-C1, SDM-C2, and SDM-C3.

Each SDM device on the SDM bus must have a unique address. The IRGASON has a factory default SDM address of 1, but it may be changed to any integer value between 0 and 14 (see Section 7.2, *Bandwidth*).

The sample rate for SDM output is determined by the inverse of the datalogger scan interval, as set by the user in the datalogger program. Data are output from the EC100 when a request is received from the logger, that is, a *prompted* output mode. The number of data values sent from the EC100 to the datalogger is also set by the user in the datalogger program. CRBasic, the programming language used by Campbell Scientific dataloggers, uses the **EC100()** instruction to get data from an IRGASON. This instruction is explained in detail under Section 10.1, *EC100() Instruction*.

8.2 USB or RS-485 Output

In contrast to the SDM output mode, which is prompted by a datalogger, data can also be output from the EC100 via USB or RS-485 in an unprompted mode. In this case, the EC100 sends out data without initiation from the receiving device at a rate determined by the EC100. Only one unprompted output type, USB or RS-485, may be selected at a given time. RS-485 output is recommended if cable lengths exceed 100 meters. If a Campbell Scientific datalogger is not being used to collect the data from the IRGASON, either unprompted mode is recommended.

To use USB or RS-485 output, connect a USB or RS-485 cable from the EC100 to the receiving device (see Section 6.3, *Wiring and Connections*), and configure the settings (see Section 7, *Settings*).

The **Unprompted Output** setting must be set to **USB** or **RS-485**.

If **RS-485** is selected, the **RS485 Baud Rate** must be set.

The **Unprompted Output Rate** must be set to the desired output rate.

All output data are formatted as comma delimited ASCII. Each record terminates with a carriage return and line feed. TABLE 8-1 lists the elements in each output array, and FIGURE 8-1 shows an example USB data feed in terminal mode.

Data Element	Description	Units/comments
1	U _x	m/s
2	U _y	m/s
3	U _z	m/s
4	Sonic temperature	°C
5	Sonic diagnostic flag	
6	CO ₂ density	mg/m ³
7	H ₂ O density	g/m ³
8	Gas diagnostic flag	
9	Air temperature	°C
10	Air pressure	kPa
11	CO ₂ signal strength	Nominally 0.0 to 1.0
12	H ₂ O signal strength	Nominally 0.0 to 1.0
13	Not used	
14	Counter	Arbitrary
15	Signature	Arbitrary in hexadecimal

```
Terminal
0.06839,-0.06224,-0.02411,22.46829,0,974.604,6.063,0,20.578,87.568,0.924,0.881,0.081,145948,31c2
0.06837,-0.06242,-0.02403,22.50268,0,974.850,6.064,0,20.575,87.569,0.924,0.881,0.081,145963,91ea
0.06840,-0.06241,-0.02407,22.49048,0,974.671,6.067,0,20.581,87.567,0.924,0.881,0.081,145978,df30
0.06837,-0.06238,-0.02408,22.44196,0,974.606,6.064,0,20.578,87.567,0.924,0.881,0.081,145993,bbe6
0.06830,-0.06261,-0.02400,22.46109,0,974.561,6.064,0,20.572,87.568,0.924,0.881,0.080,146008,e80d
0.06824,-0.06271,-0.02410,22.51471,0,974.700,6.066,0,20.571,87.567,0.924,0.881,0.080,146023,4d22
```

FIGURE 8-1. An example of USB data output in terminal mode

The final data element in each row or output array is the signature. The signature is a four character hexadecimal value that is a function of the sequence and number of bytes in the output array. The recording device (i.e., PC or datalogger) calculates its own signature using each transmitted byte until encountering the transmitted signature. The computed signature and the transmitted signature are compared. If they match, the data were received correctly. This is very similar to a cyclic redundancy check (CRC).

In most situations, a PC begins by reading the ASCII data and extracting the last four ASCII characters and casting them as Long data type. The signature is then calculated on the science data sent from the IRGASON, starting with CO₂ and ending on the counter. All the characters after the counter are not part of the signature. Once the signature is computed using the following algorithm, it is compared to the transmitted signature. If signatures do not match, the data should be disregarded.

Following is an example implementation of Campbell Scientific's signature algorithm in the programming language C. To generate the signature of an output array of bytes, the "seed" needs to be initialized to 0xaaaa and a pointer passed to the first byte of the output array. The number of bytes in the output array should be entered in as the "swath". The returned value is the computed signature.

```
//signature(), signature algorithm.
// Standard signature is initialized with a seed of 0xaaaa.
// Returns signature.
unsigned short signature( unsigned char* buf, int swath,
unsigned short seed ) {
unsigned char msb, lsb;
unsigned char b;
int i;
msb = seed >> 8;
lsb = seed;
for( i = 0; i < swath; i++ ) {
b = (lsb << 1) + msb + *buf++;
if( lsb & 0x80 ) b++;
msb = lsb;
lsb = b;
}
return (unsigned short)((msb << 8) + lsb);
}
```

8.3 Analog Outputs

If analog output is enabled, the EC100 will output two analog signals that correspond to CO₂ density and H₂O density. These signals range from 0 to 5000 mV. TABLE 8-2 gives the multipliers and offsets for the analog outputs. Note that the analog outputs contain no sonic data.

CAUTION

Be aware that the absence of diagnostic data in analog output could make troubleshooting difficult if the user is not aware of potential problems with the instrumentation.

Density (mg m ⁻³)	Voltage Output Multiplier (mg m ⁻³ V ⁻¹)	Offset (mg m ⁻³)
CO ₂	386.32	-102.59
H ₂ O	8.65	-2.26

9. Maintenance

IRGASON operation requires six maintenance tasks:

- routine maintenance
- wick maintenance
- analyzer window cleaning
- zero and span
- replacing the analyzer desiccant / scrubber bottles
- factory recalibration

9.1 Routine Maintenance

Periodically do the following:

- Check the humidity indicator card in the EC100 enclosure. If the highest dot has turned pink, replace or recharge the desiccant bags. Replacement desiccant may be purchased (pn 6714) or old desiccant packs may be recharged by heating in an oven. See the manual *ENC10/12*, *ENC12/14*, *ENC14/16*, *ENC16/18*, available at www.campbellsci.com, for more details on recharging desiccant bags.
- Make sure the LED Status Lights on the EC100 panel are green. If not, verify that all connections are secure and that the instruments are powered. Also check the individual diagnostic bits for the specific fault. See TABLE 10-2, *Bits in the Sonic Diagnostic Flag* and TABLE 10-3, *Bits in the Gas Diagnostic Flag*.

9.2 Wick Maintenance

9.2.1 Sonic Wicks

The IRGASON cannot measure wind when water droplets completely obscure the face of the sonic transducers. If the site experiences frequent rainfall, using wicks on the sonic transducers may be desirable. The wicks help remove water. Under some conditions, however, droplets may build up and remain on the transducer faces. As soon as the water droplets evaporate or are removed, the IRGASON will again measure wind. Remove the water droplets by dabbing a cotton swab or tissue on the faces of the transducers. The user must use discretion to determine if wicks are necessary. If wicks are not used, gently remove the wicks from the sonic transducers, taking care not to damage or peel the matching layer (rubber tips) from the brass housing of the transducers.

Remove the wicks during the winter. The wicks will accumulate snow or freezing rain, resulting in blockage of the sonic signals. The CSAT3 Sonic Wick Spares Kit (pn 28902) consists of three top wicks, three bottom wicks, adhesive, and an installation tool (see FIGURE 9-2). The installation tool is used by placing a wick over the angled end of the tool, placing the straight end of the tool gently against the transducer face, and sliding the wick down the tool onto the transducer. When installing wicks, be sure they are located in the proper position. The top wick must be flush with the transducer face, with the wick tail located at the lowest point of the transducer (see FIGURE 9-1). The end of the bottom transducer wick must extend above the transducer face by one-half to one mesh line (see FIGURE 9-1). Secure the wicks to the transducer with a drop of adhesive which is provided in the CSAT3 Sonic Wick Spares Kit (pn 28902). Take care that the adhesive is not deposited on the transducer face.

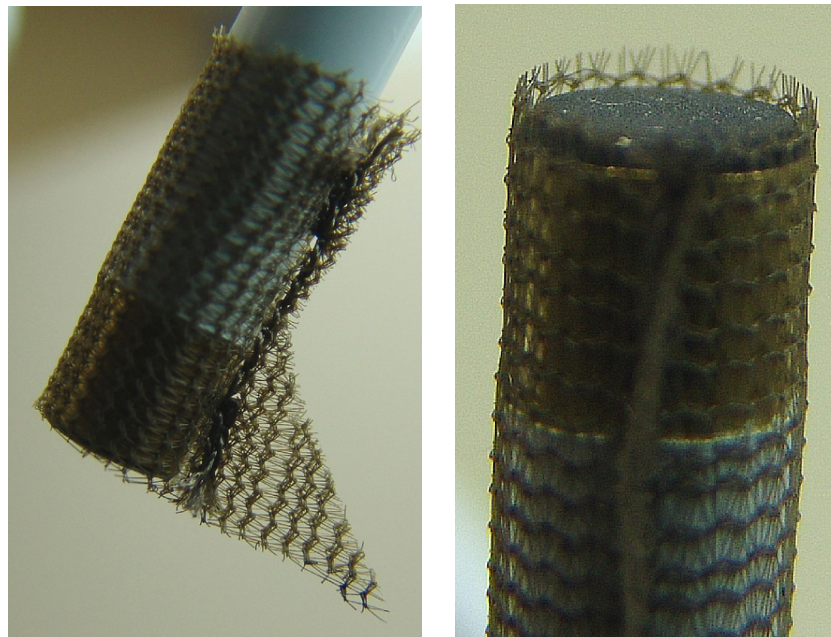

FIGURE 9-1. Proper location of the sonic top wick (left) and bottom wick (right)

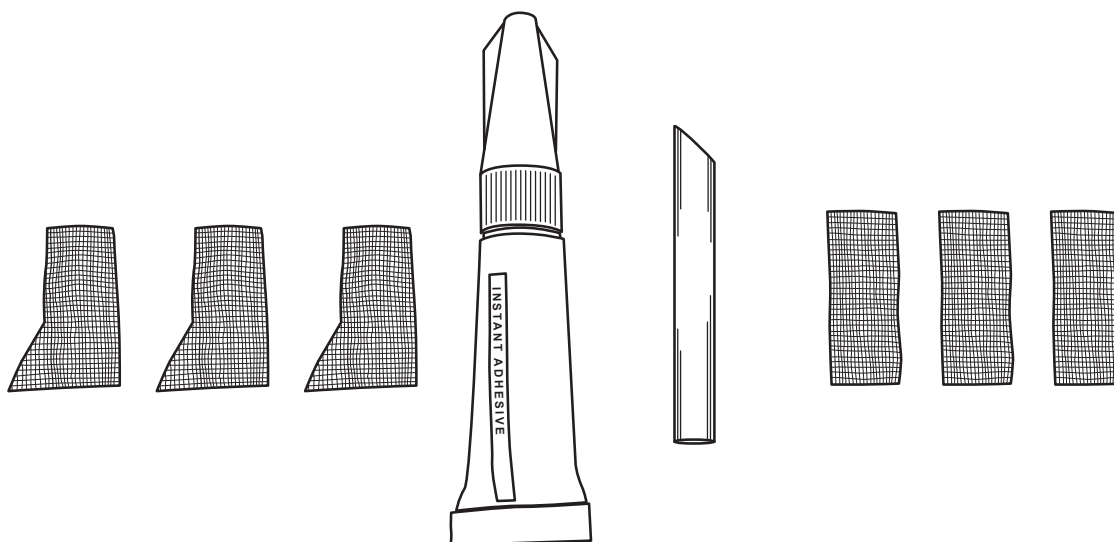

FIGURE 9-2. PN 28902 CSAT3 Sonic Wick Spares Kit contents

9.2.2 Gas Analyzer Wicks

IRGASON gas analyzer windows are polished and slanted at an angle to prevent water from collecting on their surfaces. However, due to increased surface tension at the interface with the snout, water can pool at the edges and partially block the optical path and attenuate the signal. To minimize the occurrence of such events and the resulting data loss, consider using wicks. The weave of the wick fabric promotes capillary action that wicks the water away from the edge of the windows. The seam and the straight edge of the wicks are permeated with a rubberized compound to prevent them from shifting during operation.

Proper installation of the wicks is critical. They should not block or encroach on the optical path. Before installation, record signal strengths for both H₂O and CO₂. Following installation, these values should be unchanged.

Wicks are available as listed in TABLE 9-1.

TABLE 9-1. Rain Wick Replacement Parts		
Wick	Campbell Scientific, Inc Part Number	Campbell Scientific Description
Bottom Wick	28652	FAB EC150/IRGASON RAIN WICK BOTTOM
Top Wick	28653	FAB EC150/IRGASON RAIN WICK TOP

The top wick has a short seam which has to be aligned with the short side of the top snout. The angled edge of the wick must closely follow the edge of the window without encroaching on the optical path (see FIGURE 9-3, *Proper location of the sonic top wick and bottom wick*). The bottom wick is installed in a similar manner, except the long seam should be aligned with the long side

of the bottom snout. Once in place, the wicks should fit snugly over the cylindrical part of the snout without any creases or wrinkles.

The wicks are constructed with a UV-resistant fabric and should function over long time periods. Nevertheless, they should be inspected periodically. Check for contamination from dust, pollen, pitch or other debris. If needed, wash them in warm water with mild detergent or replace them. When performing the zero-and-span procedure, the wicks should be removed before installing the zero-and-span shroud.

Remove the wicks during the winter. The wicks will accumulate snow or freezing rain, resulting in blockage of the optical path. Besides the wicks, controlling the heaters in the snouts is another method the user may consider in preventing data loss during precipitation and condensation events. The heaters can be controlled statically using the **Setup** window in ECMon or dynamically using a datalogger (see Section 10.2, *EC100Configure()* Instruction for more details).



FIGURE 9-3. Proper location of the gas analyzer top wick (left) and bottom wick (right)

9.3 Gas-Analyzer Window Cleaning

The windows of the analyzer should be cleaned if the signal strength for CO₂ or H₂O drops below 0.7 or 70% of the original value. These values may be monitored in the output data, or they can be viewed with ECMon. To clean the windows, use isopropyl alcohol (2-propanol / isopropanol) and a cotton swab or a non-scratching tissue or cloth. Verify that following cleaning the signal strengths are restored to values close to 1.0.

9.4 Zero and Span

As is the case with all optical instruments, the IRGASON's gas analyzer measurements may drift slightly with exposure to natural elements. Therefore, routine maintenance requires a periodic zero-and-span procedure. The

frequency with which this should be done is heavily dependent on the environmental conditions in which the instrument is making measurements. Campbell Scientific recommends that a new instrument, or an instrument that has been moved to a new location, should have a monthly zero and span procedure performed. Additionally, it is recommended to always zero and span the analyzer after cleaning the windows (see Section 9.3, *Gas-Analyzer Window Cleaning*). After the first several zero-and-span procedures, the rate of drift in gain and offset (explained later in this section) will be better understood for the existing environmental conditions. A regimented protocol for zero and span of the instrument initially, will allow the user to assess the appropriate time interval between zero and span procedures. However, if the IRGASON is being used at a site with large seasonal changes in ambient conditions, the zero-and-span procedure should be done at least seasonally.

In situations in which spanning the instrument is extremely difficult (for example, in below freezing temperature conditions or in very remote sites), performing a monthly zero will help mitigate the drift in the analyzer's measurements.

The first part of the following procedure simply measures the CO₂ and H₂O zero and span, without making adjustments. This allows the CO₂ and H₂O gain factors to be calculated. These gain factors quantify the state of the analyzer before the zero-and-span procedure, and in theory could be used to correct recent measurements for drift. The last part of the zero-and-span procedure adjusts internal processing parameters to correct subsequent measurements.

If the zero-and-span procedure is being performed off-site (e.g., in a lab), be sure to mount the IRGASON on the lab stand (pn 27278). This will ensure the analyzer is in the correct upright orientation and has the correct optical alignment.

It is imperative that the zero-and-span procedure be done correctly and not rushed; allocate plenty of time for the procedure (at least an hour).

CAUTION

Resting the analyzer on its side during the zero-and-span procedure may result in measurement inaccuracy.

To check and then set the IRGASON zero and span, follow the steps below:

1. Remove power from the EC100.
2. If not already done, clean the windows and snouts with alcohol and a non-scratching tissue or cloth.

CAUTION

Make sure the alcohol and any residual water completely evaporate from the analyzer before proceeding with the zero-and-span procedure.

3. As shown in FIGURE 9-4, position the IRGASON zero-and-span shroud (pn 26390) over the upper and lower snouts. To do this, twist the two ends of the shroud together to minimize the length of the shroud. Make sure the rubber seals on the ends of the shroud are clean and in good condition. Position one end of the shroud over the lower snout and twist the top part

of the shroud, allowing it to extend and cover the upper snout; while doing so, avoid making contact with the sonic transducers. Continue twisting the shroud until it is fully extended and covering both snouts. Twist the shroud so that the gas tubes and temperature thermistor cable are directed towards the back of the sensor. Hang the tubes and cable over the trunk of the sensor to alleviate any strain on the optical arms. See FIGURE 9-4, *The zero-and-span shroud mounted on the zero-and-span stand.*

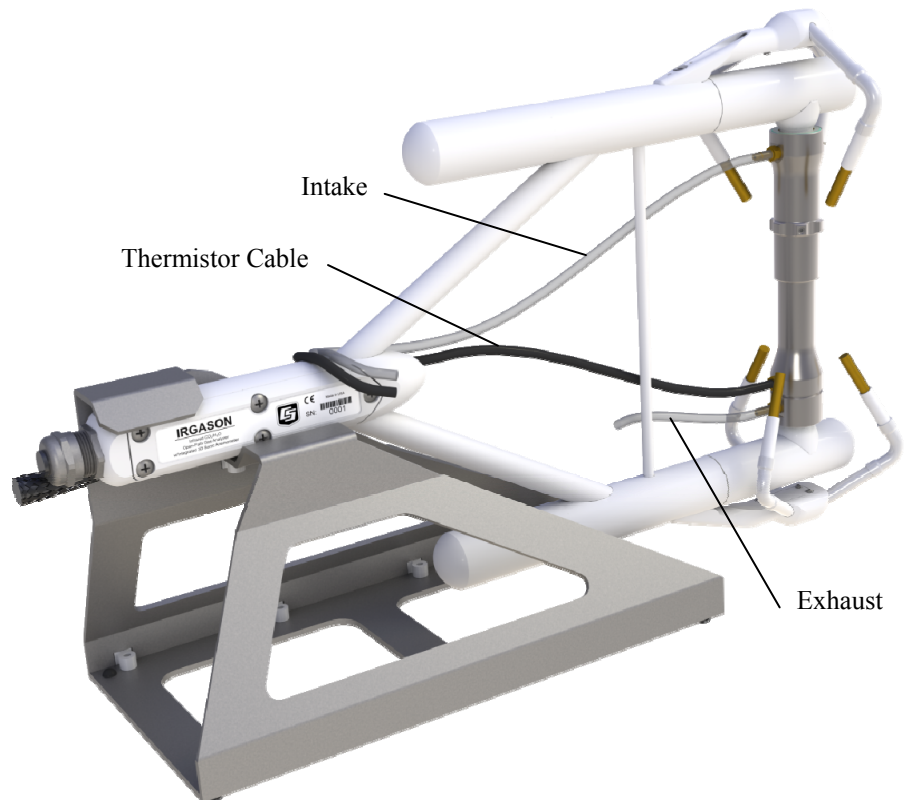

FIGURE 9-4. *The zero-and-span shroud mounted on the zero-and-span stand. The top tube is the gas intake, the black cable is the temperature thermistor, and the short bottom tube is the gas exhaust.*

4. Disconnect the IRGASON temperature sensor from the EC100 and connect the shroud temperature sensor in its place.
5. Connect the EC100 to a PC with the EC100 USB cable (pn 26561).
6. Resume power to the EC100. Wait for all the **Gas** and **Power** LED status lights on the EC100 panel to turn green.
7. Launch ECMon, select the appropriate USB port, and click **Connect**. The main screen should now be reporting real-time CO₂ and H₂O concentrations. Click **Zero/Span**. A graph will appear in the lower half of the zero-and-span window showing measured CO₂ and H₂O concentrations (see FIGURE 9-5).

8. Connect a gas tank of known CO₂ concentration to a pressure regulator, then to a flow controller, and finally to the intake of the shroud. Optimally, the concentration of span CO₂ should be near the concentration of CO₂ being measured in the field. Begin with both the pressure regulator and flow controller turned off. Then use the pressure regulator to slowly increase pressure to the recommended setting for the flow controller. Next set the flow between 0.4 and 0.6 l/min. Watch the ECMon zero-and-span graph for the CO₂ measurement readings to stabilize (5 to 10 minutes). Once stable, write down the reported CO₂ concentration.

NOTE

Use mixtures of CO₂ and ambient air for the CO₂ span gas. The use of reference CO₂ gas mixtures in pure nitrogen will lead to errors due to a carrier gas effect on pressure-broadening of the CO₂ absorption lines since oxygen gas has a smaller line-broadening coefficient than nitrogen.

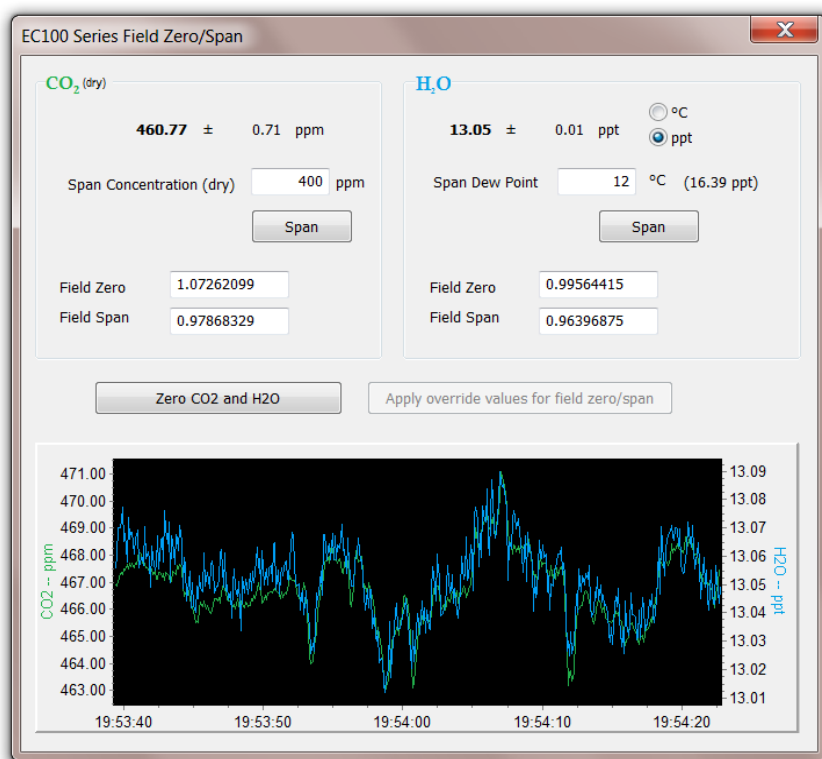

FIGURE 9-5. ECMon zero-and-span window

9. Remove the CO₂ span gas from the inlet of the shroud, and replace it with H₂O span gas from a dew-point generator or another standard reference. Because water molecules can adsorb to inside of the tubing and the shroud, it may take many minutes for the H₂O concentration to stabilize. If desired, increase the flow rate for the first several minutes to more quickly stabilize the system before returning it to between 0.4 and 0.6 l/min to make the H₂O measurement. Write down the reported H₂O concentration.

10. Remove the H₂O span gas, and connect a zero air source (no CO₂ or H₂O) to the inlet tube of the shroud. As described in step 8, use a pressure regulator and flow controller so that zero air flows through the shroud between 0.4 and 0.6 l/min. Wait for the measurement readings to stabilize (this may require several minutes) and write down the reported values for CO₂ and H₂O concentrations. If the readings remain erratic, ensure that flow of the zero air is sufficient and the shroud is correctly seated on the snouts.
11. Examine the measurements that were written down for span CO₂, span H₂O, and zero air. Compute the drift in instrument gain using the following equation:

$$gain = \frac{span_{actual}}{span_{meas} - zero_{meas}}$$

where,

- span_{actual} = known concentration of the span gas
- span_{meas} = measured concentration of the span gas
- zero_{meas} = measured concentration in zero gas.

Note that in the zero-and- span window of ECMon, span_{actual} is reported to the right of the box where the user enters the span dew-point temperature. The software calculates span_{actual} by taking into account the dew-point temperature and current ambient temperature and pressure. The equations used for this calculation may be found in Appendix B. If drift (offset or gain) for CO₂ or H₂O is excessive, it may be time to replace the desiccant and CO₂ scrubber bottles (see Section 9.5, *Replacing Desiccant and Scrubber Bottles*).

12. With zero air still flowing and measurements stabilized, click on the **Zero CO₂ and H₂O** button in the ECMon zero-and-span window.

NOTE

Air flow into the shroud should be close to the recommended rate. If the flow is too low, the shroud will not be properly flushed; if it is too high, the air pressure within the shroud will be too high, and the analyzer will not be zeroed and spanned properly.

13. Remove the zero air source and replace it with the CO₂ span gas. Allow the gas to flow through the shroud, maintaining a flow between 0.4 and 0.6 l/min. Wait for readings to stabilize.
14. In the zero-and-span window, enter the known concentration of CO₂ (in ppm) in the box labeled **Span Concentration (dry)** and press **Span**.
15. Replace the CO₂ span gas with an H₂O span gas of known dew point. Allow the gas to flow through the shroud; higher flows may be desired for a couple of minutes to more quickly establish equilibrium before resuming a flow between 0.4 and 0.6 l/min. Wait for the readings to stabilize.

16. Enter the known dew point (in C°) in the box labeled **Span Dew Point** and press **Span**.
17. The zero-and-span procedure is now complete. Remove the shroud, reconnect the IRGASON® temperature probe, and prepare the site for normal operation.

9.5 Replacing Desiccant and Scrubber Bottles

If more than two years have passed since replacing the desiccant / scrubber bottles within the IRGASON, or if the zero-and-span readings have drifted excessively (see Section 9.4, *Zero and Span*), the bottles should be replaced. To do this, twist the scrubber-bottle covers of the upper and lower arms counter-clockwise until they detach (they should loosen by hand). Remove the IRGASON chemical bottles (pn 26510) from inside the covers, and replace them with new bottles lid-first (see FIGURE 9-6). Once this is done, firmly screw the covers back on the arms. Allow the sensor to equilibrate for at least 24 hours (longer if in high humidity), and then perform a zero-and-span procedure. If readings continue to be suspect, the sensor may need factory recalibration (see Section 9.6, *Factory Recalibration*).

DANGER

The scrubber bottles contain strong oxidizing agents. Avoid direct contact with the chemicals inside the bottles. Also, ensure your work area is well ventilated and free of any reactive compounds, including liquid water. Store used chemical bottles in a sealed container until disposal.

The chemical bottles should be disposed of according to local and federal regulations. For more information, MSDS (Material Safety Data Sheets) for the chemicals are available in Appendix C and at www.campbellsci.com.

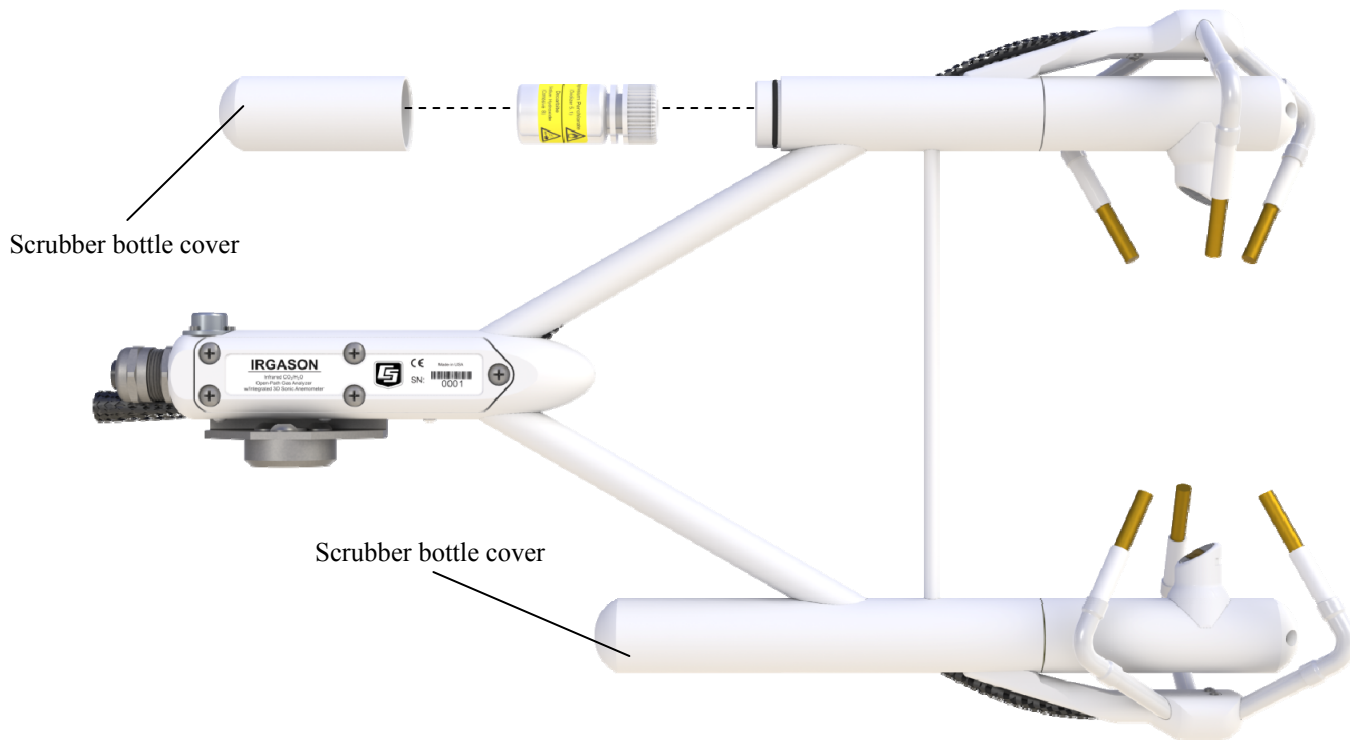

FIGURE 9-6. Replacing the desiccant and CO₂ scrubber bottles

9.6 Factory Recalibration

When the IRGASON is manufactured, the gas analyzer calibrated over a wide range of temperatures, pressures, and gas concentrations. All CO₂ calibration gases used in this process are mixtures of CO₂ in ambient air and are traceable to the WMO Mole Fraction Scale maintained by the Central Carbon Dioxide Laboratory and the Carbon Cycle Greenhouse Gases Group of the Global Monitoring Division / National Oceanographic and Atmospheric Administration in Boulder, CO, USA.

After an extended period of time in the field, the IRGASON gas analyzer may need to undergo this factory calibration again to ensure valid measurements. When recalibration is deemed necessary, contact Campbell Scientific.

The IRGASON sonic anemometer also undergoes an initial factory calibration. Usually this calibration remains valid unless a transducer fails or damage to the instrument leads to a change in geometry. The sonic anemometer requires calibration when

- it develops a wind offset greater than the specification.
- it sets diagnostic flags under dry conditions with little to no wind and with no obstruction in the ultra sonic paths.

The wind offset is tested by creating a zero wind environment by encircling the sensor with a large plastic bag (unused refuse bag), using caution not to block the sonic paths. See the manual *CSAT3 Three Dimensional Sonic Anemometer*, Section 11.2.2, *Test for Wind Offset*, available at www.campbellsci.com. When recalibration is deemed necessary, contact Campbell Scientific.

10. Datalogger Programming

The datalogger is programmed in the CRBasic language, which features two instructions for communication with the EC100 via SDM. The first instruction is **EC100()**, which reads measurement data from the EC100. The second is the **EC100Configure()**, which receives and sends configuration settings.

10.1 EC100() Instruction

The **EC100()** instruction is used to retrieve data from the IRGASON via SDM. The instruction syntax is:

EC100 (*Dest*, *SDMAddress*, *EC100Cmd*)

Dest is the input variable name in which to store data from the IRGASON. The length (i.e., number of data elements) of the input variable array will depend on the selected value for *EC100Cmd*. A value of -99999 will be loaded into *Dest*(1) if a signature error on SDM data occurs.

<i>EC100Cmd</i>	Dest Variable Length
0	8
1	12
2	13

SDMAddress defines the address of the IRGASON with which to communicate. Valid SDM addresses are 0 through 14. Address 15 is reserved for the **SDMTrigger()** instruction.

EC100Cmd is a parameter that requests data from the analyzer. The results for the command are returned in the array specified by the *Dest* parameter. A numeric code is entered to request the data, as shown in TABLE 10-1.

Output Mode	Data Field	Description	Units
0, 1, 2,	1	Ux	m/s
	2	Uy	m/s
	3	Uz	m/s
	4	Sonic Temperature	°C
	5	Sonic Diagnostic Flag	
	6	CO ₂ Density	mg/m ³
	7	H ₂ O Density	g/m ³
	8	Gas Diagnostic Flag	
1, 2	9	Air Temperature	°C
	10	Air Pressure	kPa
	11	CO ₂ Signal Strength	nominally 0.0 ≤ strength ≤ 1.0
	12	H ₂ O Signal Strength	nominally 0.0 ≤ strength ≤ 1.0
2	13	Sample Cell Pressure Differential	kPa

As shown in TABLE 10-1, all output modes give two diagnostic values: **Sonic Diagnostic Flag** and **Gas Diagnostic Flag**. The values contain a bit field with each bit representing a monitored condition. When a certain condition is detected, the corresponding bit is set. The value remains set until the event that caused the condition is no longer present. TABLE 10-2 and TABLE 10-3 describe the bits in the sonic diagnostic flag and the gas diagnostic flag, respectively.

bit	hex value	decimal	Name	Function
0	0x1	1	Low Amp	Amplitude is too low
1	0x2	2	High Amp	Amplitude is too high
2	0x4	4	Tracking	Poor signal lock
3	0x8	8	Hi 3 Axis DC	Delta temperature exceeds limits
4	0x10	16	Acquiring	Acquiring ultrasonic signals
5	0x20	32	Cal Mem Err	Sonic head calibration signature error

TABLE 10-3. Bits in the Gas Diagnostic Flag

bit	hex value	decimal	Name	Function
0	0x1	1	Bad Data	Data are suspect (there is an active diagnostic flag)
1	0x2	2	Sys Fault	General system fault
2	0x4	4	Sys Startup	Gas analyzer is starting up
3	0x8	8	Motor Speed	Motor speed outside of limits
4	0x10	16	TEC Temp	TEC temperature exceeds limits
5	0x20	32	Light Power	Source power exceeds limits
6	0x40	64	Light Temp	Invalid source temperature
7	0x80	128	Light I	Source current exceeds limits
8	0x100	256	Power Off	Gas head not powered
9	0x200	512	Chan Err	Gas input data out of sync with home pulse
10	0x400	1024	Amb Temp	Invalid ambient temperature
11	0x800	2048	Amb Press	Invalid ambient pressure
12	0x1000	4096	CO ₂ I	CO ₂ I exceeds limits
13	0x2000	8192	CO ₂ I ₀	CO ₂ I ₀ exceeds limits
14	0x4000	16384	H ₂ O I	H ₂ O I exceeds limits
15	0x8000	32768	H ₂ O I ₀	H ₂ O I ₀ exceeds limits
16	0x10000	65536	CO ₂ I ₀ Var	Moving variation in CO ₂ I ₀ exceeds limits
17	0x20000	131072	H ₂ O I ₀ Var	Moving variation in H ₂ O I ₀ exceeds limits
18	0x40000	262144	CO ₂ I ₀ Ratio	CO ₂ signal level too low
19	0x80000	524288	H ₂ O I ₀ Ratio	H ₂ O signal level too low
20	0x100000	1048576	Cal Mem Err	Gas head calibration signature error
21	0x200000	2097152	Heater Control	Heater control error
22	0x400000	4194304	Diff Pressure	Differential pressure exceeds limits

10.2 EC100Configure() Instruction

EC100Configure() provides a third option, beside the ECmon software and DevConfig utility, for retrieving and modifying settings. ECmon and Device Configuration are user-interactive, whereas the **EC100Configure()** instruction allows automated control under CRBasic datalogger programming.

EC100Configure() is a processing instruction. Whether running in pipeline mode or sequential mode, the datalogger will execute the instruction from the processing task. This functionality allows **EC100Configure()** to be placed in conditional statements. Running from the processing task has ramifications when attempting to execute **EC100Configure()** while other SDM instructions are executing in pipeline mode. **EC100Configure()** locks the SDM port during the duration of its execution. If the pipelined SDM task sequencer needs to run while the SDM is locked, it will be held off until the instruction completes. This locking will likely result in skipped scans when reconfiguring an IRGASON.

For the IRGASON to save settings, it must go through a lengthy write-read-verify process. To avoid saving the settings after each set command, the result code can be used to determine if any settings were modified from their original value. When a change is detected, the save settings command (command code 99) can then be sent to the IRGASON. The *DestSource* parameter variable should be set to 2718 to save the settings. The reception of this command is acknowledged, but since it takes up to a second to complete, a successful return code does not mean that all data were successfully written to the appropriate non-volatile memory.

The instruction syntax is:

EC100Configure (*Result*, *SDMAddress*, *ConfigCmd*, *DestSource*)

Result is a variable that contains a value indicating the success or failure of the command. A result code of 0 means the command was successful. If reading a setting, 0 in the result code means that the value in the *DestSource* variable is the value the desired setting has in the IRGASON. When writing a setting, if the result code is 0, the value and setting were compatible, but the value was not changed because it contained the same value that was sent. A result code of 1 from the set operation means that the value was valid, different, set and acknowledged. This allows CRBasic code to control whether or not to save the settings. A result code of *NAN* (i.e., not a number) indicates the setting was not changed or acknowledged, or a signature failure occurred.

SDMAddress defines the address of the IRGASON to configure. Valid SDM addresses are 0 through 14 (address 15 is reserved for **SDMTrigger()**).

ConfigCmd is a variable that indicates whether to get or set a setting. The options are listed in TABLE 10-4.

ConfigCmd Variable		Setting Description (some settings list possible values for the DestSource variable)
Set	Retrieve	
0	100	Bandwidth: 5 = 5 Hz, 10 = 10 Hz, 12 = 12.5 Hz, 20 = 20 Hz, 25 = 25 Hz
1	101	Unprompted output: 10 = 10 Hz, 25 = 25 Hz, 50 = 50 Hz
2	102	Pressure sensor: 0 = EC100 basic, 1 = user-supplied, 2 = EC100 enhanced, 3 = none (use fixed value)
3	103	Differential pressure: 0 = disable, 1 = enable
4	104	Fixed pressure value
5	105	Pressure offset
6	106	Pressure gain
7	107	Temperature sensor: 0 = IRGASON/EC150 temperature probe 1 = EC155 sample cell thermistor 2 = EC155 sample cell thermocouple 3 = None (use fixed value) 4 = Auto-select
8	108	Fixed temperature value
9	109	Unprompted output mode: 0 = Disable, 1 = USB, 2 = RS-485
10	110	RS-485 baud rate
11	111	Zero-and-span control: 0 = inactive, 1 = zero, 2 = span CO ₂ , 3 = span H ₂ O (See Section 10.2.1, <i>ConfigCmd 11 Zero-and-span Control</i>)
12	112	CO ₂ span concentration
13	113	H ₂ O span dew point temperature
14	114	CO ₂ zero
15	115	CO ₂ span
16	116	H ₂ O zero
17	117	H ₂ O span
18 or 218	118	Heater voltage (0 to 4.5375V, -1 = Off) (See Section 10.2.2, <i>ConfigCmd 18 Heater Voltage</i>)
19	119	Reserved
20	120	Analog output enable: 0 = disable, 1 = enable
21	121	Power down: 0 = Gas head on, 1 = Gas head off
99	N/A	Save settings to EEPROM memory

DestSource is a variable that will contain the value to read when getting a setting, or that will contain the value to send when writing a setting to the IRGASON.

10.2.1 ConfigCmd 11 Zero-and-span Control

To perform zeroing of CO₂ and H₂O, *ConfigCmd 11* is set to 1. After the IRGASON completes the zero, it will write the value to -1. The datalogger program can poll this value or simply wait for a period of time to allow the zeroing to complete. To perform CO₂ span, the *CO₂ Span Concentration* setting (*ConfigCmd 12*) must be written to the proper value in ppm CO₂ prior to setting the zero-and-span control setting (*ConfigCmd 11*) to 2. After the CO₂ span is completed, the value of the zero-and-span control setting will change to -2. H₂O span is similar to CO₂. First the *H₂O Span Dew Point Temperature* value (*ConfigCmd 13*) must be written to the desired value. Then the zero-and-span control setting is set to 3. After the IRGASON completes the span, the span control setting is written as -3. *ConfigCmd 14* through *17* automatically store the results of the zero-and-span procedure. Each result is a coefficient used in the gas analyzer's algorithms for calculating gas concentrations.

10.2.2 ConfigCmd 18 Heater Voltage

Normally, the **EC100Configure()** instruction is run in the processing task. Skipped scans can occur when the **EC100Configure()** instruction executes. When changing operational parameters, these skipped scans are acceptable. However, they may not be acceptable when changing the heater voltage. *ConfigCmd 218* allows **EC100Configure()** to operate in the SDM task, thus avoiding skipped scans. When using *ConfigCmd 218*, the command must be a constant and the instruction cannot be placed in a conditional statement.

The IRGASON includes heaters near the optical windows. This setting gives the voltage applied to the heater. It can be set to -1 to disable the heater, or set it to any voltage between 0 and 4.5375 V.

The heater resistance is 5 ohms, so the heater power (P_H) expressed as Watts (W) is given by:

$$P_H = \frac{V^2}{5}$$

The maximum power at 4.5375 V is 4.12 W.

Operating the heaters following a precipitation event encourages water droplets on the windows to evaporate more quickly, thus restoring signal strength. Heater usage may also be desired to prevent formation of dew and frost on the windows, which leads to invalid measurements due to differences in absorption spectra of liquid water and water vapor.

The heaters, however, should be disabled when they are not needed. Heating near the sample volume may cause air density fluctuations that can affect flux measurements. Disabling the heaters will also conserve power. Care should be taken to avoid operating the heaters if the system voltage is too low or if the ambient temperature is > 45°C. Operation at temperatures > 45°C will overload the thermoelectric coolers of the detector, as indicated by the TEC Temp diagnostic flag (see TABLE 10-3, *Bits in the Gas Diagnostic Flag*).

A datalogger may be used to dynamically control the heaters by using input from another moisture sensor such as a leaf-wetness sensor. When the sensor

output indicates moisture is present, the datalogger can send the **EC100Configure()** instruction to the IRGASON and enable the heaters.

10.3 Example CRBasic Program

```
'CR3000 Series Datalogger

Public sonic_irga(12)
Alias sonic_irga(1) = Ux
Alias sonic_irga(2) = Uy
Alias sonic_irga(3) = Uz
Alias sonic_irga(4) = Ts
Alias sonic_irga(5) = diag_sonic
Alias sonic_irga(6) = CO2
Alias sonic_irga(7) = H2O
Alias sonic_irga(8) = diag_irga
Alias sonic_irga(9) = cell_tmpr
Alias sonic_irga(10) = cell_press
Alias sonic_irga(11) = CO2_sig_strgth
Alias sonic_irga(12) = H2O_sig_strgth
Units Ux = m/s
Units Uy = m/s
Units Uz = m/s
Units Ts = C
Units diag_sonic = arb
Units CO2 = mg/m^3
Units H2O = g/m^3
Units diag_irga = arb
Units cell_tmpr = C
Units cell_press = kPa
Units CO2_sig_strgth = arb
Units H2O_sig_strgth = arb

DataTable (ts_data,TRUE,-1)
    DataInterval (0,0,mSec,10)

    Sample (12,Ux,IEEE4)
EndTable

BeginProg
    Scan (100,mSec,0,0)
        EC100 (Ux,1,1)
        CallTable ts_data
    NextScan
EndProg
```

11. Theory of Operation

11.1 IRGASON Sonic Anemometer

The CSAT3 measures wind speeds and the speed of sound by determining the time of flight of sound between pairs of transducers. However, unlike many other commercial anemometers, it does not use simple threshold detection to determine the ultrasonic times of flight. Instead, it uses advanced digital signal processing techniques to determine the arrival of the transmitted ultrasonic signal. In comparison to other systems, the digital signal processing techniques result in more accurate, lower noise measurements.

11.1.1 Wind Speed

Each axis of the sonic anemometer pulses two ultrasonic signals in opposite directions. The time of flight of the first signal (out) is given by:

$$t_o = \frac{d}{c + u_a} \quad (1)$$

and the time of flight of the second signal (back) is given by:

$$t_b = \frac{d}{c - u_a} \quad (2)$$

where t_o is the time of flight out along the transducer axis, t_b is the time of flight back, in the opposite direction, u_a is the wind speed along the transducer axis, d is the distance between the transducers, and c is the speed of sound.

The wind speed, u_a , along any axis can be found by inverting the above relationships, subtracting Eq. (2) from (1), and solving for u_a .

$$u_a = \frac{d}{2} \left[\frac{1}{t_o} - \frac{1}{t_b} \right] \quad (3)$$

The wind speed is measured on all three non-orthogonal axes to give u_a , u_b , and u_c , where the subscripts a, b, and c refer to the non-orthogonal sonic axes.

The non-orthogonal wind speed components are then transformed into orthogonal wind speed components, u_x , u_y , and u_z , with the following:

$$\begin{bmatrix} u_x \\ u_y \\ u_z \end{bmatrix} = A \begin{bmatrix} u_a \\ u_b \\ u_c \end{bmatrix} \quad (4)$$

where A is a 3 x 3 coordinate transformation matrix, that is unique for each CSAT3 and is stored in ROM memory.

11.1.2 Temperature

The sonically determined speed of sound can be found from the sum of the inverses of Eq. (1) and (2). The CSAT3 corrects online for the effect of wind blowing perpendicular to the sonic path. No additional off-line corrections are required as suggested by Liu et al., 2001.

$$c = \frac{d}{2} \left[\frac{1}{t_o} + \frac{1}{t_b} \right] \quad (5)$$

The speed of sound in moist air is a function of temperature and humidity and is given by:

$$c^2 = \gamma P / \rho = \gamma R_d T_v = \gamma R_d T (1 + 0.61q) \quad (6)$$

where γ is the ratio of specific heat of moist air at constant pressure to that at constant volume, P is pressure, ρ is air density, R_d is the gas constant for dry air, T_v is virtual temperature, T is the air temperature, and q is the specific humidity defined as the ratio of the mass of water vapor to the total mass of air (Kaimal and Gaynor, 1991; Wallace and Hobbs, 1977).

Note that γ is a function of specific humidity. It would be convenient if the effects of humidity could be consolidated into one term.

The specific heats for moist air at constant pressure and volume are given by:

$$\begin{aligned} C_p &= qC_{pw} + (1 - q)C_{pd} \\ &= C_{pd}(1 + 0.84q) \end{aligned} \quad (7a)$$

$$\begin{aligned} C_v &= qC_{vw} + (1 - q)C_{vd} \\ &= C_{vd}(1 + 0.93q) \end{aligned} \quad (7b)$$

where C_p and C_v are the specific heats of moist air at constant pressure and volume, C_{pw} and C_{vw} is the specific heat of water vapor, and C_{pd} and C_{vd} is the specific heat of dry air, respectively (Fleagle and Businger, 1980).

Substitute Eq. (7a) and (7b) into (6) and ignore the higher order terms. This yields

$$c^2 = \gamma_d R_d T_s = \gamma_d R_d T (1 + 0.51q) \quad (8)$$

where T_s is sonic virtual temperature and γ_d is the ratio of specific heat of dry air at constant pressure to that at constant volume (Fleagle and Businger, 1980; Kaimal and Gaynor, 1991; Kaimal and Businger, 1963; Schotanus et al., 1983). With Eq. (8), the effect of humidity, on the speed of sound, is included in the sonic virtual temperature.

The sonic virtual temperature, in degrees Celsius, is given by Eq. (9), where $\gamma_d = 1.4$ and $R_d = 287.04 \text{ J}\cdot\text{K}^{-1}\cdot\text{kg}^{-1}$.

$$T_s = \frac{c^2}{\gamma_d R_d} - 273.15 \quad (9)$$

11.2 IRGASON Gas Analyzer

The IRGASON gas analyzer is a non-dispersive mid-infrared absorption analyzer. Infrared radiation is generated in the upper arm of the analyzer head before propagating along a 15 cm optical path. Chemical species located within the optical beam will absorb radiation at characteristic frequencies. A mercury cadmium telluride (MCT) detector in the lower arm of the gas analyzer measures the decrease in radiation intensity due to absorption, which can then be related to analyte concentration using the Beer-Lambert Law:

$$P = P_o e^{-\epsilon cl} \quad (10)$$

where P is irradiance after passing through the optical path, P_o is initial irradiance, ϵ is molar absorptivity, c is analyte concentration, and l is pathlength.

In the IRGASON, radiation is generated by applying constant power to a tungsten lamp, which acts as a 2200 K broadband radiation source. Specific wavelengths are then selected using interference filters located on a spinning chopper wheel. For CO₂, light with a wavelength of 4.3 μm is selected, as it corresponds to the molecule's asymmetric stretching vibrational band. For H₂O, radiation at 2.7 μm , corresponding to water's symmetric stretching vibrational band, is used.

The IRGASON gas analyzer is a dual wavelength single-beam analyzer; thus, rather than using a separate reference cell and detector, the initial intensity of the radiation is calculated by measuring the intensity of nearby, non-absorbing wavelengths (4 μm for CO₂ and 2.3 μm for H₂O). These measurements account for any source and detector aging and window contamination.

The chopper wheel spins at a rate of 100 revolutions per second, and the detector is measured 512 times per revolution, resulting in a detector sampling rate of 512 kHz. The detector is maintained at -40°C using a 3-stage thermoelectric cooler and is coupled to a low-noise pre-amp module.

The EC100 electronics digitize and process the detector data (along with ancillary data such as sample temperature and pressure) to give the CO₂ and H₂O densities after each chopper wheel revolution (100 Hz). These are then filtered to the user-specified bandwidth. The EC100 also synchronously measures and processes data from the IRGASON sonic anemometer.

11.3 Theory References

- Kaimal, J. C. and Businger, J. A.: 1963, “A Continuous Wave Sonic Anemometer-Thermometer”, *J. Applied Meteorol.*, **2**, 156-164.
- Kaimal, J. C. and Gaynor, J. E.: 1991, “Another Look at Sonic Thermometry”, *Boundary-Layer Meteorol.*, **56**, 401-410.
- Fleagle, R. G. and Businger, J. A.: 1980, *An Introduction to Atmospheric Physics*, Academic Press, Inc., New York.
- Liu, H., Peters, G., and Foken, T.: 2001, “New Equations for Sonic Temperature Variance and Buoyancy Heat Flux with an Omnidirectional Sonic Anemometer”, *Boundary-Layer Meteorol.*, **100**, 459-468.
- Schotanus, P., Nieuwstadt, F. T. M., and de Bruin, H. A. R.: 1983, “Temperature Measurement with a Sonic Anemometer and its Application to Heat and Moisture Fluxes”, *Boundary-Layer Meteorol.*, **26**, 81-93.
- Wallace, J. M. and Hobbs, P. V.: 1977, *Atmospheric Science an Introductory Survey*, Academic Press, Inc., New York.

Appendix A. Filter Bandwidth and Time Delay

The EC100 measures CO₂, H₂O, 3-D wind components, and sonic temperature from the IRGASON at 100 Hz and then applies a user-selectable low-pass filter. The available filter bandwidths are 5, 10, 12.5, 20, and 25 Hz. FIGURE A-1 shows the amplitude response of these filters. The EC100 filters provide a flat pass band, a steep transition from pass band to stop band, and a well-attenuated stop band. FIGURE A-2 compares the EC100 10 Hz filter to a 50 ms moving average filter with approximately the same bandwidth.

The ideal eddy-covariance filter is one that is wide enough to preserve the low-frequency signal variations that transport flux and narrow enough to attenuate high-frequency noise. In addition, to minimize aliasing (the misinterpretation of high-frequency variation as lower-frequency variation), the measurement bandwidth must be less than half of the sample rate (datalogger scan rate). Two factors complicate choosing the ideal eddy-covariance bandwidth. First, the flux signal bandwidth varies from one installation to another, and the flux signal bandwidth varies with mean wind speed at a given installation. Second, the fast sample rate required to anti-alias a desired signal bandwidth may result in large, unwieldy data sets.

Fortunately, the covariance calculation itself relaxes the need for the ideal bandwidth. First, the time-averaged (typically thirty-minute) covariance calculations inherently reduce noise, and second, aliasing does not degrade the accuracy of covariance calculations. Therefore, the factory default for the EC100 bandwidth (20 Hz) is rather wide to preserve the signal variations that transport flux, and that bandwidth is suitable for most flux applications. Additional bandwidths are available for experimenters desiring to match the EC100 filter bandwidth to their data acquisition sample rate to avoid aliasing. In this case, the selected bandwidth should be one-half of the sample rate (datalogger scan rate), and experimenters should be careful to avoid attenuation of flux-carrying signals.

The EC100 electronics synchronously sample the gas analyzer and sonic anemometer of the IRGASON. However, experimenters wishing to synchronize their EC100 data with other measurements (e.g., energy balance sensors) in the data acquisition system must account for the time delay of the EC100 filter. TABLE A-1 shows the delay for each of the filter bandwidths. The EC100 provides a constant time delay for all spectral components within each filter's pass band.

The following examples show how to use TABLE A-1. To synchronize EC100 data to other datalogger measurements when the datalogger scan rate is 25 Hz and the EC100 bandwidth is set to 20 Hz (a 200 ms delay from TABLE A-1), delay the non-EC100 data by five datalogger scans. Similarly, for a 10 Hz datalogger scan rate and the same 20 Hz EC100 bandwidth, delay the non-EC100 data by two datalogger scans to match the EC100 data. For the best synchronicity, choose a datalogger scan interval that is an integer multiple of the EC100 filter delay.

The EC100 measures gas and wind data at 100 Hz, and 100 Hz data are down-sampled to the datalogger scan rate through SDM communications (see Section 8, *EC100 Outputs*). This process synchronizes EC100 gas and wind data with other signals measured by the datalogger to within ± 5 ms (plus or minus one-half of the inverse of 100 Hz). Alternatively, when sending data to a non-Campbell data acquisition system, the EC100 down-samples its USB and RS-485 outputs to a user-selectable rate of 10, 25, or 50 Hz. Although the gas and wind data from the EC100 remain synchronized, the user must consider the down-sampled output interval when synchronizing the EC100 data with other measurements in their system. These slower output intervals increase the asynchronicity of EC100 data with other system measurements.

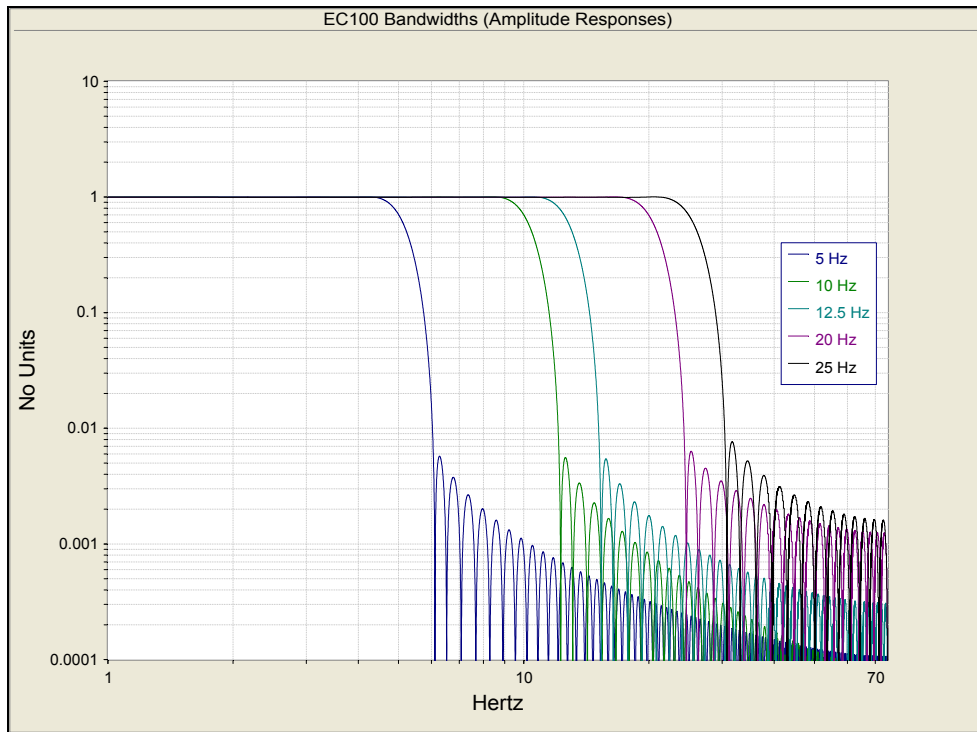

FIGURE A-1. Frequency and amplitude response of EC100 filter at various bandwidths

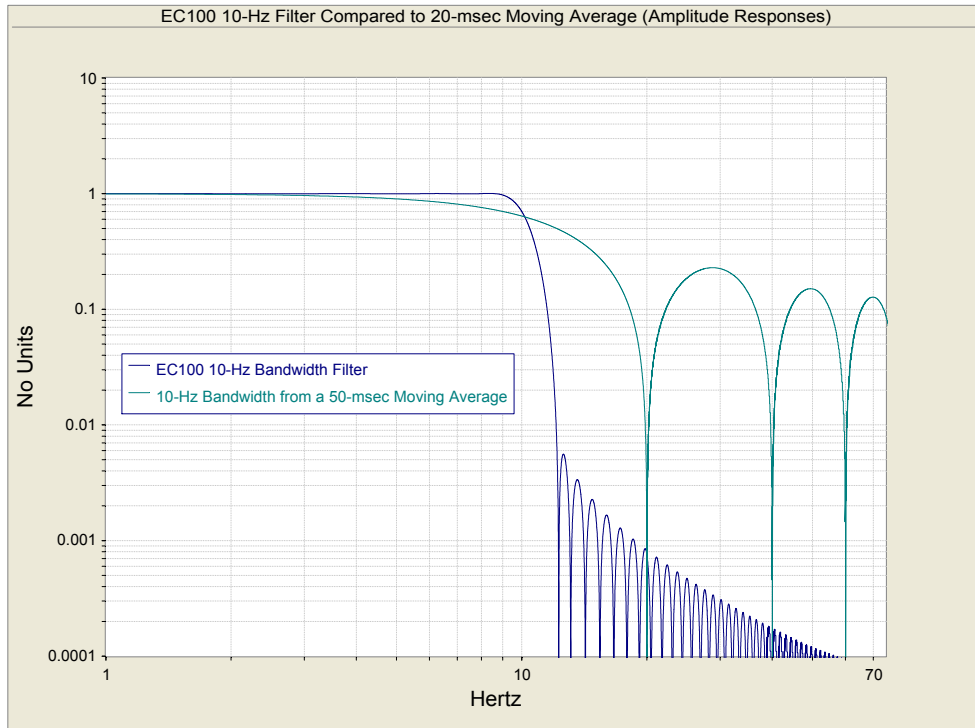

FIGURE A-2. Frequency response comparison of the EC100 10 Hz bandwidth and a 50 ms moving average

TABLE A-1. Filter Time Delays for Various Bandwidths	
Bandwidth (Hz)	Time Delay (ms)
5	800
10	400
12.5	320
20	200
25	160

Appendix B. Equations

TABLE B-1 lists variables and constants used in the following equations.

TABLE B-1. Table of Equation Variables and Constants		
Variable or Constant	Description	Units
ρ_c	CO ₂ Mass Density	mg·m ⁻³
ρ_v	H ₂ O Mass Density	g·m ⁻³
ρ_d	Mass Density of Dry Air	g·m ⁻³
X_c	CO ₂ Molar Mixing Ratio (concentration relative to dry air)	μmol·mol ⁻¹
X_v	H ₂ O Molar Mixing Ratio (concentration relative to dry air)	mmol·mol ⁻¹
M_c	Molecular Weight of CO ₂	44 mg·mmol ⁻¹
M_d	Molecular weight of dry air	0.029 g·mmol ⁻¹
M_v	Molecular weight of H ₂ O	0.018 g·mmol ⁻¹
P	Ambient Pressure	kPa
R	Universal Gas Constant	8.3143 x 10 ⁻⁶ kPa·m ³ ·K ⁻¹ ·mmol ⁻¹
T	Ambient Temperature	°C
e	Vapor Pressure	kPa
f	Enhancement Factor	Arbitrary
T_d	Dew Point Temperature	°C
T_{d_tmp}	Temporary variable for dew point calculation	Arbitrary

Mass Density from Molar Mixing Ratios

$$\rho_c = \frac{X_c M_c}{10^6} \left(\frac{P}{R(T + 273.15)} - \frac{\rho_v}{M_v} \right) \quad (\text{B-1})$$

$$\rho_v = \frac{X_v P M_v}{R(T + 273.15)(1000 + X_v)} \quad (\text{B-2})$$

$$\rho_d = \frac{(P - e)M_d}{R(T + 273.15)} \quad (\text{B-3})$$

$$\rho_d = \frac{\left(P - \frac{X_v P}{1000 + X_v} \right) M_d}{R(T + 273.15)} \quad (\text{B-4})$$

$$\rho_d = \left(\frac{PM_d}{R(T + 273.15)} \right) \left(1 - \frac{X_v}{1000 + X_v} \right) \quad (\text{B-5})$$

Dew Point from Molar Mixing Ratio

$$T_d = \frac{240.97 T_{d_tmp}}{17.502 - T_{d_tmp}} \quad (\text{B-6}^2)$$

$$T_{d_tmp} = \ln \left(\frac{X_v P}{0.61121 \cdot f(1000 + X_v)} \right) \quad (\text{B-7}^2)$$

$$f = 1.00072 + (3.2 \times 10^{-5})P + (5.9 \times 10^{-9})PT^2 \quad (\text{B-8}^2)$$

Water Vapor Molar Mixing Ratio from Dew Point

$$X_v = \frac{e}{P - e} 1000 \quad (\text{B-9})$$

$$e = 0.61121 \cdot f \cdot \text{EXP} \left(\frac{17.502 T_d}{240.97 + T_d} \right) \quad (\text{B-10}^2)$$

Water Vapor Mass Density from Dew Point

$$\rho_v = \frac{(0.018)(0.61121)f}{R(T + 273.15)} \text{EXP} \left(\frac{17.502 T_d}{240.97 + T_d} \right) \quad (\text{B-11}^2)$$

Vapor Pressure from Molar Mixing Ratio and Water Vapor Density

$$e = \frac{X_v P}{1000 + X_v} \quad (\text{B-12})$$

$$e = \frac{\rho_v R(T + 273.15)}{M_v} \quad (\text{B-13})$$

¹ Leuning, R (2004) Measurements of Trace Gas Fluxes in the Atmosphere Using Eddy Covariance: WPL Revisited. *The Handbook of Micrometeorology*, 29, 119-132. New York: Kluwer Academic Publishers. Eq. 6.23

²Buck, A L (1981) New Equations for Computing Vapor Pressure and Enhancement Factor. *Journal of Applied Meteorology* 20, 1527-1532. Eqs. 2a, 3a, and 6



Appendix C. Material Safety Data Sheets (MSDS)

MSDS are available for chemicals used in IRGASON filters. The MSDS samples below are made available for convenience. However, chemical manufacturers may change MSDS at any time. Up-to-date MSDS are available at www.campbellsci.com.

C.1 Magnesium Perchlorate MSDS

GFS CHEMICALS, INC. P.O. Box 245 Powell, OH 43065 740-881-5501 (Tel.) 740-881-5989 (Fax) 1-800-424-9300 (Chemtrec 24Hr. Info.)			
<u>MATERIAL SAFETY DATA SHEET</u>			
55			
MAGNESIUM PERCHLORATE, ANHYDROUS			
<u>CHEMICAL NAME & SYNONYMS</u>	<u>DOT CLASS</u>	<u>SARA TITLE 313</u>	
Magnesium Perchlorate, Anhydrous	5.1/II	No	
	<u>TSCA listed</u>	- Yes	
<u>FORMULA</u>	<u>REPORTABLE QUANTITY</u>	<u>F.W.</u>	<u>CAS#</u>
Mg(ClO ₄) ₂	N/A	223.23	10034-81-8
<u>PHYSICAL DATA</u> Melting point 250°C. Density 2.21. Deliquescent. Very soluble in water with evolution of heat.			
<u>APPEARANCE & ODOR</u> White granules and powder. Odorless.			
<u>REACTIVITY & CONDITIONS TO AVOID</u> Stable. Strong dehydrating agent. Potentially strong oxidant (over 150°C). Do not heat with organic matter, flammables or combustibles. Avoid contact with strong acids.			
<u>FIRE HAZARDS</u> May cause fire or explosion when heated with combustibles or organic matter. Avoid inhalation of smoke or fumes. Firefighters wear SCBA. NFPA 1-0-3			
<u>EXTINGUISHER</u>	<u>FLASHPOINT</u>	<u>LEL</u>	<u>UEL</u>
Water.	N/A	N/A	N/A
<u>HEALTH HAZARDS</u> Irritating to skin, eyes and nasal passages. Overexposure may lead to dermatitis externally or diarrhea internally. Toxicity is low and indeterminate. OSHA TLV/ACGIH PEL not established. Perchlorate has been shown to interfere with iodine uptake by the thyroid in test animals. Studies on workers in plants where perchlorate salts are manufactured have shown no thyroid abnormalities. Thyroid effects on humans continues to be studied. No evidence of carcinogenicity.			
<u>SPECIAL PRECAUTIONS</u> Wear goggles and rubber gloves while handling. Store away from organics, combustibles, strong acids. Do not use to dry organic liquids.			
<u>FIRST AID</u> Wash skin and eyes well with water. After washing eyes get medical attention. If swallowed give ice to suck, water to drink and call a physician.			
<u>SPILLS & LEAKS</u> Wash up spill immediately with water. Disposal to sanitary drain, check local regulations. If spilled on wooden floor, wash up thoroughly with water and remove flooring for disposal. Rinse mops thoroughly with water. Do not use sawdust, rags or paper as absorbant.			
<u>CATALOG #</u>	<u>PREPARED BY</u>	<u>DATE</u>	
55	MDM	April 22, 2005	

C.2 Decarbite MSDS

Material Safety Data Sheet May be used to comply with OSHA's Hazard Communication Standard, 29 CFR 1910.1200. Standard must be consulted for specific requirements.		 U.S. Department of Labor Occupational Safety and Health Administration (Non-Mandatory Form) Form approved OMB No. 1218-0072	
IDENTITY (As Used on Label and List) DECARBITE		Note: Blank spaces are not permitted. If any item is not applicable, or no information is available, the space must be marked to indicate that.	
Section I			
Manufacturer's Name P. W. PERKINS CO., INC.		Emergency Telephone Number 1-800-424-9300	
Address (Number, Street, City, State, and ZIP Code) 221 Commissioners Pike		Telephone Number for Information (856) 769-3525	
Woodstown NJ 08098-2032 USA		Date Prepared 1/2/07	
Section II — Hazardous Ingredients/Identity Information			
Hazardous Components (Specific Chemical Identity; Common Name(s))		OSHA PEL	ACGIH TLV
Sodium Hydroxide, caustic soda, CAS #1310-73-2			Other Limits Recommended
Chemical formula: NaOH			% (optional)
D.O.T. Shipping name: Sodium Hydroxide, Solid			
D.O.T. Hazard Class: 8, Corrosive, Packaging Group II			
D.O.T. ID #UN1823			
PEL = 2mg/m ³			
TLV = 2mg/m ³			
Hazardous Substance RO 1000			
Proprietary formulation indicating CO ₂ Adsorbent			
Sodium Hydroxide: CAS #1310-73-2			
Non Fibrous Silicate: CAS #1318-00-9			
Section III — Physical/Chemical Characteristics			
Boiling Point @ 760 mm Hg: 1388°C		Specific Gravity (H ₂ O = 1) 2.13 @ 20°C	
Vapor Pressure (mm Hg.) 42 mm Hg @ 1000°C		Melting Point NA	
Vapor Density (AIR = 1) NA		Evaporation Rate (Butyl Acetate = 1) NA	
Solubility in Water Completely soluble			
Appearance and Odor Light tan, no distinct odor			
Section IV — Fire and Explosion Hazard Data			
Flash Point (Method Used) No flash to 550°F ASTM D-56		Flammable Limits non flammable	
		LEL NA	UEL NA
Extinguishing Media Product not combustible, foam/CO ₂ or dry chemical can be used.			
Special Fire Fighting Procedures Protective clothing/self contained breathing apparatus should be worn by fire fighters in area where product is stored.			
Unusual Fire and Explosion Hazards Material is stable (non explosive), non flammable. Will react with varying degrees of intensity on exposure to water and strong acids.			
Form 30-510 Printed and Sold by  190 Baldwin Ave., Jersey City, NJ 07308 • (800) 631-3098 • (201) 795-5400			OSHA 174, Sept. 1985

Section V — Reactivity Data			
Stability	Unstable		Conditions to Avoid Contact with water causes strong exothermic reaction. Avoid strong acids contact.
	Stable	X	
Incompatibility (Materials to Avoid) Water, strong acids, aluminum, tin, zinc			
Hazardous Decomposition or Byproducts Exposure to air results in formation of H ₂ O and carbonate			
Hazardous Polymerization	May Occur		Conditions to Avoid Material not known to polymerize
	Will Not Occur	X	
Section VI — Health Hazard Data			
Route(s) of Entry: Inhalation? 4-Extreme Skin? 4-Extreme Ingestion? 3-Severe			
Health Hazards (Acute and Chronic) Corrosive to all body tissue which it comes in contact. The chronic local effect may consist of multiple areas of superficial destruction of the skin. Inhalation of dust may cause varying degrees of irritation.			
Carcinogenicity: NTP? NA IARC Monographs? NA OSHA Regulated? NA			
Not listed as a carcinogen			
Signs and Symptoms of Exposure Itching, burning of skin or eyes. Temporary discomfort of breathing passages.			
Medical Conditions Generally Aggravated by Exposure Increased susceptibility to respiratory illness.			
Emergency and First Aid Procedures Flush with water. Seek medical attention. Eyes - flush with large amounts of clean water, followed by boric acid eye wash solution.			
Section VII — Precautions for Safe Handling and Use			
Steps to Be Taken in Case Material is Released or Spilled Wash area with 1 molar Hydrochloric acid or use caustic spill kit. Wash with clean water.			
Waste Disposal Method Appropriate disposal should conform with local and state health regulations.			
Precautions to Be Taken in Handling and Storing Wear protective clothing, use adequate ventilation where dust may be generated.			
Other Precautions Respirator, eye protection, gloves, lab coat or other clothing to cover exposed skin area.			
Section VIII — Control Measures			
Respiratory Protection (Specify, Type) MSA Dust Foe 77 or NIOSH approved respirator			
Ventilation	Local Exhaust	exhaust fan	Special NA
	Mechanical (General)	NA	Other NA
Protective Gloves	Impervious	Eye Protection	Goggles/face shield
Other Protective Clothing or Equipment Coveralls, chemically resistant shoes.			
Work/Hygienic Practices Wash contaminated clothes; showers & eye wash should be accessible.			
Page 2			
[FR Doc. 85-28201 Filed 11-25-85; 8:45 am] BILLING CODE 4510-26-C			

Campbell Scientific Companies

Campbell Scientific, Inc. (CSI)

815 West 1800 North
Logan, Utah 84321
UNITED STATES

www.campbellsci.com • info@campbellsci.com

Campbell Scientific Africa Pty. Ltd. (CSAf)

PO Box 2450
Somerset West 7129
SOUTH AFRICA

www.csafrica.co.za • cleroux@csafrica.co.za

Campbell Scientific Australia Pty. Ltd. (CSA)

PO Box 8108
Garbutt Post Shop QLD 4814
AUSTRALIA

www.campbellsci.com.au • info@campbellsci.com.au

Campbell Scientific do Brasil Ltda. (CSB)

Rua Apinagés, nbr. 2018 – Perdizes
CEP: 01258-00 – São Paulo – SP
BRASIL

www.campbellsci.com.br • vendas@campbellsci.com.br

Campbell Scientific Canada Corp. (CSC)

11564 - 149th Street NW
Edmonton, Alberta T5M 1W7
CANADA

www.campbellsci.ca • dataloggers@campbellsci.ca

Campbell Scientific Centro Caribe S.A. (CSCC)

300 N Cementerio, Edificio Breller
Santo Domingo, Heredia 40305
COSTA RICA

www.campbellsci.cc • info@campbellsci.cc

Campbell Scientific Ltd. (CSL)

Campbell Park
80 Hathern Road
Shephed, Loughborough LE12 9GX
UNITED KINGDOM

www.campbellsci.co.uk • sales@campbellsci.co.uk

Campbell Scientific Ltd. (CSL France)

3 Avenue de la Division Leclerc
92160 ANTONY
FRANCE

www.campbellsci.fr • info@campbellsci.fr

Campbell Scientific Ltd. (CSL Germany)

Fahrenheitstraße 13
28359 Bremen
GERMANY

www.campbellsci.de • info@campbellsci.de

Campbell Scientific Spain, S. L. (CSL Spain)

Avda. Pompeu Fabra 7-9, local 1
08024 Barcelona
SPAIN

www.campbellsci.es • info@campbellsci.es