

INSTRUCTION MANUAL



CS215 Temperature and Relative Humidity Probe

Revision: 4/18



Copyright © 2005-2018
Campbell Scientific, Inc.

Guarantee

This equipment is guaranteed against defects in materials and workmanship. We will repair or replace products which prove to be defective during the guarantee period as detailed on your invoice, provided they are returned to us prepaid. The guarantee will not apply to:

- Equipment which has been modified or altered in any way without the written permission of Campbell Scientific
- Batteries
- Any product which has been subjected to misuse, neglect, acts of God or damage in transit.

Campbell Scientific will return guaranteed equipment by surface carrier prepaid. Campbell Scientific will not reimburse the claimant for costs incurred in removing and/or reinstalling equipment. This guarantee and the Company's obligation thereunder is in lieu of all other guarantees, expressed or implied, including those of suitability and fitness for a particular purpose. Campbell Scientific is not liable for consequential damage.

Please inform us before returning equipment and obtain a Repair Reference Number whether the repair is under guarantee or not. Please state the faults as clearly as possible, and if the product is out of the guarantee period it should be accompanied by a purchase order. Quotations for repairs can be given on request. It is the policy of Campbell Scientific to protect the health of its employees and provide a safe working environment, in support of this policy a "Declaration of Hazardous Material and Decontamination" form will be issued for completion.

When returning equipment, the Repair Reference Number must be clearly marked on the outside of the package. Complete the "Declaration of Hazardous Material and Decontamination" form and ensure a completed copy is returned with your goods. Please note your Repair may not be processed if you do not include a copy of this form and Campbell Scientific Ltd reserves the right to return goods at the customers' expense.

Note that goods sent air freight are subject to Customs clearance fees which Campbell Scientific will charge to customers. In many cases, these charges are greater than the cost of the repair.



Campbell Scientific Ltd,
80 Hathern Road,
Shepshed, Loughborough, LE12 9GX, UK
Tel: +44 (0) 1509 601141
Fax: +44 (0) 1509 270924
Email: support@campbellsci.co.uk
www.campbellsci.co.uk

PLEASE READ FIRST

About this manual

Please note that this manual was originally produced by Campbell Scientific Inc. primarily for the North American market. Some spellings, weights and measures may reflect this origin.

Some useful conversion factors:

Area: 1 in ² (square inch) = 645 mm ²	Mass: 1 oz. (ounce) = 28.35 g 1 lb (pound weight) = 0.454 kg
Length: 1 in. (inch) = 25.4 mm 1 ft (foot) = 304.8 mm 1 yard = 0.914 m 1 mile = 1.609 km	Pressure: 1 psi (lb/in ²) = 68.95 mb
	Volume: 1 UK pint = 568.3 ml 1 UK gallon = 4.546 litres 1 US gallon = 3.785 litres

In addition, while most of the information in the manual is correct for all countries, certain information is specific to the North American market and so may not be applicable to European users.

Differences include the U.S standard external power supply details where some information (for example the AC transformer input voltage) will not be applicable for British/European use. *Please note, however, that when a power supply adapter is ordered it will be suitable for use in your country.*

Reference to some radio transmitters, digital cell phones and aerials may also not be applicable according to your locality.

Some brackets, shields and enclosure options, including wiring, are not sold as standard items in the European market; in some cases alternatives are offered. Details of the alternatives will be covered in separate manuals.

Part numbers prefixed with a “#” symbol are special order parts for use with non-EU variants or for special installations. Please quote the full part number with the # when ordering.

Recycling information



At the end of this product's life it should not be put in commercial or domestic refuse but sent for recycling. Any batteries contained within the product or used during the products life should be removed from the product and also be sent to an appropriate recycling facility.

Campbell Scientific Ltd can advise on the recycling of the equipment and in some cases arrange collection and the correct disposal of it, although charges may apply for some items or territories.

For further advice or support, please contact Campbell Scientific Ltd, or your local agent.



Campbell Scientific Ltd, 80 Hathern Road, Shepshed, Loughborough, LE12 9GX,
UK Tel: +44 (0) 1509 601141 Fax: +44 (0) 1509 270924
Email: support@campbellsci.co.uk
www.campbellsci.co.uk

Precautions

DANGER — MANY HAZARDS ARE ASSOCIATED WITH INSTALLING, USING, MAINTAINING, AND WORKING ON OR AROUND **TRIPODS, TOWERS, AND ANY ATTACHMENTS TO TRIPODS AND TOWERS SUCH AS SENSORS, CROSSARMS, ENCLOSURES, ANTENNAS, ETC.** FAILURE TO PROPERLY AND COMPLETELY ASSEMBLE, INSTALL, OPERATE, USE, AND MAINTAIN TRIPODS, TOWERS, AND ATTACHMENTS, AND FAILURE TO HEED WARNINGS, INCREASES THE RISK OF DEATH, ACCIDENT, SERIOUS INJURY, PROPERTY DAMAGE, AND PRODUCT FAILURE. TAKE ALL REASONABLE PRECAUTIONS TO AVOID THESE HAZARDS. CHECK WITH YOUR ORGANIZATION'S SAFETY COORDINATOR (OR POLICY) FOR PROCEDURES AND REQUIRED PROTECTIVE EQUIPMENT PRIOR TO PERFORMING ANY WORK.

Use tripods, towers, and attachments to tripods and towers only for purposes for which they are designed. Do not exceed design limits. Be familiar and comply with all instructions provided in product manuals. Manuals are available at www.campbellsci.eu or by telephoning +44(0) 1509 828 888 (UK). You are responsible for conformance with governing codes and regulations, including safety regulations, and the integrity and location of structures or land to which towers, tripods, and any attachments are attached. Installation sites should be evaluated and approved by a qualified engineer. If questions or concerns arise regarding installation, use, or maintenance of tripods, towers, attachments, or electrical connections, consult with a licensed and qualified engineer or electrician.

General

- Prior to performing site or installation work, obtain required approvals and permits. Comply with all governing structure-height regulations, such as those of the FAA in the USA.
- Use only qualified personnel for installation, use, and maintenance of tripods and towers, and any attachments to tripods and towers. The use of licensed and qualified contractors is highly recommended.
- Read all applicable instructions carefully and understand procedures thoroughly before beginning work.
- Wear a **hardhat** and **eye protection**, and take **other appropriate safety precautions** while working on or around tripods and towers.
- **Do not climb** tripods or towers at any time, and prohibit climbing by other persons. Take reasonable precautions to secure tripod and tower sites from trespassers.
- Use only manufacturer recommended parts, materials, and tools.

Utility and Electrical

- **You can be killed** or sustain serious bodily injury if the tripod, tower, or attachments you are installing, constructing, using, or maintaining, or a tool, stake, or anchor, come in **contact with overhead or underground utility lines.**
- Maintain a distance of at least one-and-one-half times structure height, or 20 feet, or the distance required by applicable law, **whichever is greater**, between overhead utility lines and the structure (tripod, tower, attachments, or tools).
- Prior to performing site or installation work, inform all utility companies and have all underground utilities marked.
- Comply with all electrical codes. Electrical equipment and related grounding devices should be installed by a licensed and qualified electrician.

Elevated Work and Weather

- Exercise extreme caution when performing elevated work.
- Use appropriate equipment and safety practices.
- During installation and maintenance, keep tower and tripod sites clear of un-trained or non-essential personnel. Take precautions to prevent elevated tools and objects from dropping.
- Do not perform any work in inclement weather, including wind, rain, snow, lightning, etc.

Maintenance

- Periodically (at least yearly) check for wear and damage, including corrosion, stress cracks, frayed cables, loose cable clamps, cable tightness, etc. and take necessary corrective actions.
- Periodically (at least yearly) check electrical ground connections.

WHILE EVERY ATTEMPT IS MADE TO EMBODY THE HIGHEST DEGREE OF SAFETY IN ALL CAMPBELL SCIENTIFIC PRODUCTS, THE CUSTOMER ASSUMES ALL RISK FROM ANY INJURY RESULTING FROM IMPROPER INSTALLATION, USE, OR MAINTENANCE OF TRIPODS, TOWERS, OR ATTACHMENTS TO TRIPODS AND TOWERS SUCH AS SENSORS, CROSSARMS, ENCLOSURES, ANTENNAS, ETC.

Table of Contents

PDF viewers: These page numbers refer to the printed version of this document. Use the PDF reader bookmarks tab for links to specific sections.

1. Introduction	1
2. Precautions	1
3. Initial Inspection.....	1
4. QuickStart.....	1
5. Overview.....	3
6. Specifications.....	4
6.1 Temperature Measurement.....	4
6.2 Relative Humidity Measurement	5
7. Installation.....	5
7.1 Wiring to Datalogger	5
7.2 Datalogger Programming.....	6
7.3 SDI12Recorder() Instruction.....	6
7.4 Installation.....	6
7.4.1 Installation in a 41303-5A or 41303-5B 6-Plate Shield	7
7.4.2 Installation in a 41003-5 or 41003-5A 10-Plate Shield Using 6637 Collar Adapter.....	8
7.4.3 Installation in a RAD06 6-Plate Shield or RAD10 10-Plate Shield.....	8
7.4.4 Mount the Shield.....	8
8. Operation.....	9
8.1 Sensor Measurement	9
8.2 Measurements at Fast Scan Rates	10
8.3 Long Cables	10
8.4 Power Conservation	10
8.5 Measuring Multiple SDI-12 Sensors.....	11
9. Troubleshooting and Maintenance.....	11
9.1 Troubleshooting	11
9.2 Maintenance	11
9.3 Calibration.....	12
9.4 Sensor Element Replacement Procedure.....	12
10. Attributions and References	15

Appendices

A. Importing Short Cut Code Into CRBasic Editor ...	A-1
B. Example Programs.....	B-1
C. Environmental Performance.....	C-1
C.1 Tests to Defined Standards.....	C-1
C.2 Exposure to Pollutants.....	C-1
C.3 Operating Range of RH Element.....	C-2
C.4 Measurement Below 0 °C.....	C-2
D. SDI-12 Sensor Support	D-1
D.1 Introduction.....	D-1
D.2 SDI-12 Command Basics	D-1
D.2.1 Acknowledge Active Command (a!).....	D-2
D.2.2 Send Identification Command (aI!).....	D-2
D.2.3 Start Verification Command (aV!).....	D-3
D.2.4 Address Query Command (?!)	D-3
D.2.5 Change Address Command (aAb!)	D-3
D.2.6 Start Measurement Commands (aM!)	D-3
D.2.7 Start Concurrent Measurement Commands (aC!)	D-4
D.2.8 Start Measurement Commands with Cyclic Redundancy Check (aMC! and aCC!)	D-6
D.2.9 Stopping a Measurement Command	D-6
D.2.10 Send Data Command (aD0! ... aD9!)	D-6
D.2.11 Continuous Measurement Command (aR0! ... aR9!)	D-7
D.3 SDI-12 Transparent Mode.....	D-7
D.3.1 Changing an SDI-12 Address.....	D-7
D.3.2 Changing an SDI-12 Address – CR200(X) Series	D-8
D.4 References.....	D-9

Figures

7-1. CS215 and 41303-5A Radiation Shield (left) and RAD06 Radiation Shield (right) on a tripod mast.....	8
7-2. CS215 and 41303-5A Radiation Shield on a CM200 Series Crossarm.....	9
9-1. Correct fit of sensor element (side view).....	14
9-2. Incorrect fit of sensor element (side view)	15
C-1. Normal operating conditions of RH element.....	C-2
D-1. CR1000 example of using the SDI-12 transparent mode to change the SDI-12 address from 0 to 3. Sensor is connected to control port 1.....	D-8
D-2. CR200(X) example of using the SDI-12 transparent mode to change the SDI-12 address from 0 to 1	D-9

Tables

7-1. Wire Colour, Function, and Datalogger Connection.....	5
C-1. Environmental Tests.....	C-1
D-1. Campbell Scientific Sensor SDI-12 Command and Response Set..	D-1
D-2. Example aM! Sequence.....	D-4

D-3. Example aC! Sequence D-5

CRBasic Examples

B-1. CR1000X Program for Measuring the CS215B-1
B-2. CR200(X) Program for Measuring the CS215.....B-2

CS215 Temperature and Relative Humidity Probe

1. Introduction

The CS215 Temperature and Relative Humidity probe is designed for general meteorological and other datalogging applications. It uses the SDI-12 communications protocol to communicate with any SDI-12 recorder, simplifying installation and programming.

For Edlog datalogger support, check the availability of an older manual at www.campbellsci.com/old-manuals.

2. Precautions

- READ AND UNDERSTAND the *Safety* section at the front of this manual.
- When opening the shipping package, do not damage or cut the cable jacket. If damage to the cable is suspected, contact Campbell Scientific.
- Although rugged, the CS215 should be handled as a precision scientific instrument.
- Santoprene[®] rubber, which composes the black outer jacket of the CS215 cable, will support combustion in air. It is used because of its resistance to temperature extremes, moisture, and UV degradation. It is rated as slow burning when tested according to U.L. 94 H.B. and passes FMVSS302. However, local fire codes may preclude its use inside buildings.

3. Initial Inspection

- Check the packaging and contents of the shipment. If damage occurred during transport, immediately file a claim with the carrier. Contact Campbell Scientific to facilitate repair or replacement.
- Check model information against the shipping documents to ensure the expected products and the correct lengths of cable are received. Model numbers are found on each product. On cables and cabled items, the model number is usually found at the connection end of the cable. Report any shortages immediately to Campbell Scientific.

4. QuickStart

A video that describes datalogger programming using *Short Cut* is available at: www.campbellsci.eu/videos/cr1000x-datalogger-getting-started-program-part-3. *Short Cut* is an easy way to program your datalogger to measure the CS215 sensor and assign datalogger wiring terminals. *Short Cut* is available as a download on www.campbellsci.eu. It is included in installations of *LoggerNet*, *PC200W*, *PC400*, or *RTDAQ*.

The following procedure also describes programming with *Short Cut*.

1. Open *Short Cut* and click **Create New Program**.
2. Double-click the datalogger model.
3. In the search box under the **Available Sensors and Devices** heading, start typing CS215, or find the sensor in the **Sensors | Meteorological | Relative Humidity & Temperature** folder. Double-click **CS215 Temperature & Relative Humidity Sensor**. Temperature defaults to degree Celsius. This can be changed by clicking the **Deg C** box and selecting **Deg F**, for degrees Fahrenheit, or **K** for Kelvin. **SDI-12 Address** defaults to 0. Type the correct **SDI-12 Address** for the CS215 if it has been changed from the factory-set default value. After entering the **Properties**, click on the **Wiring** tab to see how the sensor is to be wired to the datalogger.

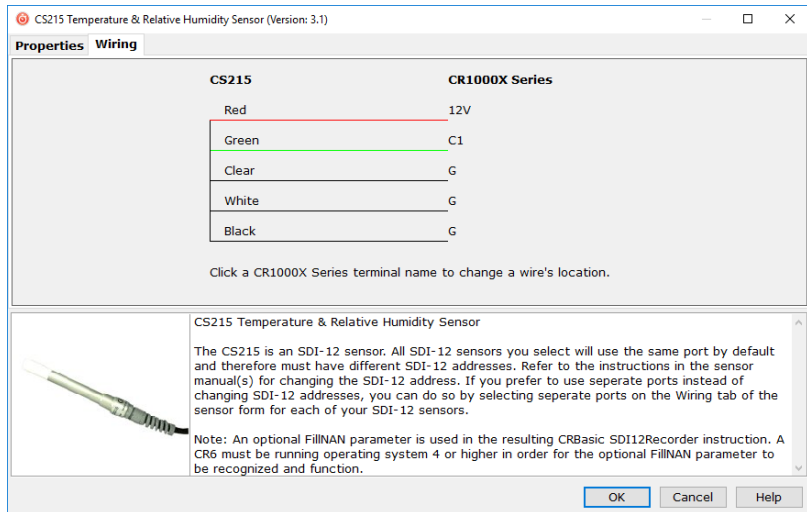
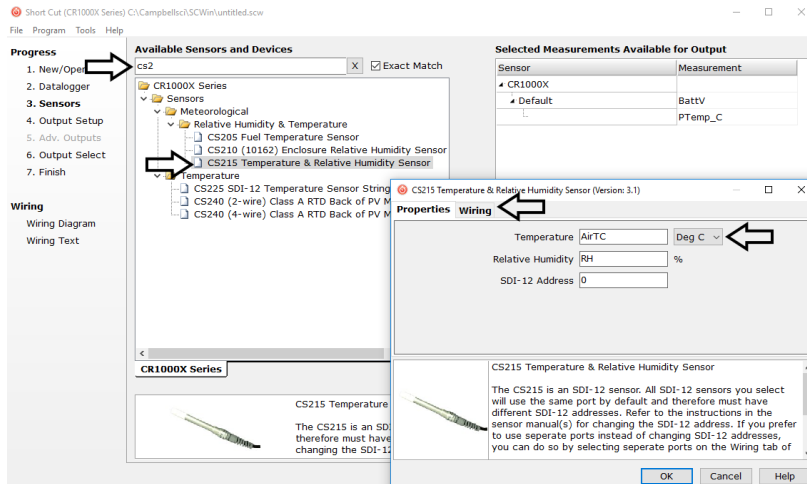

4. Select any other sensors you have.

- In **Output Setup**, type the scan rate and **Data Output Storage Interval**.

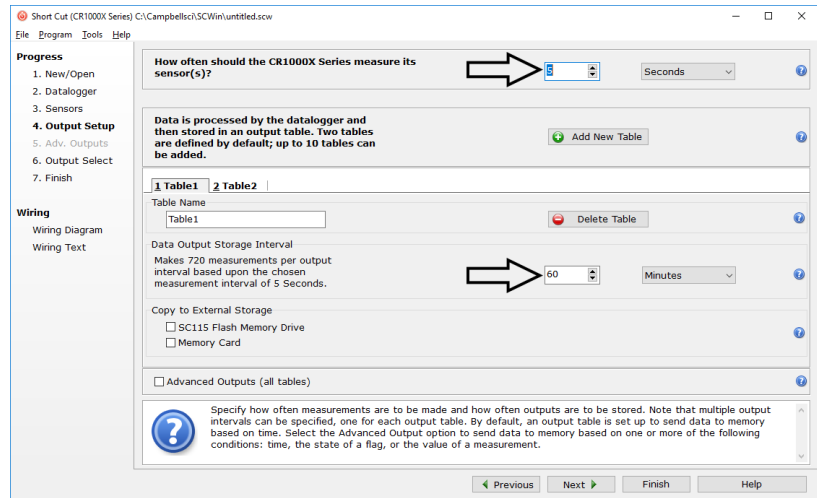

- Select the output options.

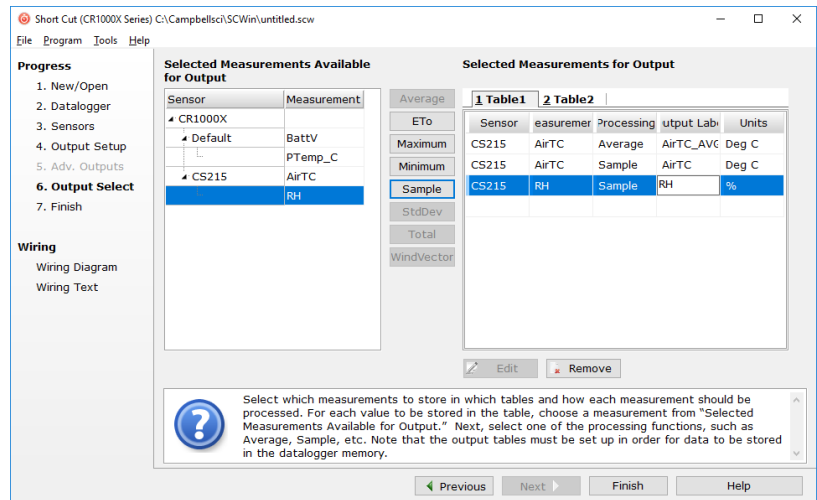

- If the sensor is connected to the datalogger, check the output of the sensor in the datalogger support software data display to make sure it is making reasonable measurements.

5. Overview

The CS215 probe uses a single chip element that incorporates both a temperature and an RH sensor. Each element is individually calibrated with the calibration corrections stored on the chip. The element is easily changed in the field, reducing downtime and calibration costs.

Electronics within the CS215 control the measurement made by the sensor element, apply temperature and linearization corrections to the readings, and present the data via SDI-12 to a datalogger.

An inner expanded PTFE filter minimizes the effects of dust and dirt on the sensor. The filter is lightweight and hydrophobic, thereby diminishing its effect on the time response of the sensor.

The probe housing is designed to withstand permanent exposure to all weather and to fit into a range of radiation shields, including compact shields.

6. Specifications

Features:

- Accurate, stable measurements
- Field-changeable element allows on-site recalibration
- Individually calibrated sensor elements require no further adjustment of the probe
- Low power consumption
- Digital SDI-12 output
- Compatible with Campbell Scientific dataloggers CR200(X) series, CR300 series, CR6 series, CR800 series, CR1000, CR1000X series, CR3000, and CR5000

Sensor Element:	Sensirion SHT75
Calibration Traceability:	NIST and NPL standards
Supply Voltage:	7 to 28 Vdc for serial numbers E13405 and newer 6 to 18 Vdc for older models
Current Consumption:	70 μ A quiescent, typical 1.7 mA during 0.7 s measurement
Diameter:	12 mm at sensor tip, maximum 18 mm at cable end
Length:	180 mm, including cable strain relief
Housing Material:	Anodized aluminium
Housing Classification:	IP65 (NEMA 4)
Filter Material:	Inner expanded PTFE filter. Filter material has a porosity of 64% and a pore size of < 3 μ m.
EMC Compliance:	Tested and conforms to IEC61326:2002

6.1 Temperature Measurement

Operating Range:	-40 to +70 °C
Accuracy:	\pm 0.3 °C at 25 °C \pm 0.4 °C over 5 to 40 °C \pm 0.9 °C over -40 to 70 °C
Response Time with Filter:	120 s (63% response time in air moving at 1 m/s)
Default Units:	Degrees Celsius

6.2 Relative Humidity Measurement

Operating Range:	0 to 100% RH (–20 to 60 °C; see Appendix C, <i>Environmental Performance</i> (p. C-1))
Accuracy at 25 °C:	±2% over 10 to 90% ±4% over 0 to 100%
Short-Term Hysteresis:	<1% RH
Temperature Dependence:	Compensated to better than ±2% over –20 to 60 °C
Typical Long-Term Stability:	Better than ±1.0% per year
Response Time with Filter:	<10 s (63% response time in air moving at 1 m/s at humidity <85%)
Environmental Performance:	See Appendix C, <i>Environmental Performance</i> (p. C-1)

7. Installation

If you are programming your datalogger with *Short Cut*, skip Section 7.1, *Wiring to Datalogger* (p. 5), and Section 7.2, *Datalogger Programming* (p. 6). *Short Cut* does this work for you. See Section 4, *QuickStart* (p. 1), for a *Short Cut* tutorial.

7.1 Wiring to Datalogger

Wire Colour	Wire Function	Datalogger Connection Terminal
Red	Power	12V
White	Power ground	G
Black	Power ground	G
Green	SDI-12 signal	C terminal ¹ or U configured for SDI-12 ²
Clear	Shield	G

¹Dedicated SDI-12 terminal on CR5000
²U channels are automatically configured by the measurement instruction.

To use more than one probe per datalogger, either connect the different probes to different terminals on the datalogger or change the SDI-12 addresses of the probes and wire them to the same terminal. Using the SDI-12 address reduces the use of terminals on the datalogger and allows probes to be connected in a “daisy-chain” fashion which can minimize cable runs in some applications. (See below for limits on the total cable length.)

The SDI-12 address of the CS215 can be set two ways:

- By sending the required commands to the sensors by using an SDI-12 recorder/datalogger that allows talk through to the sensor.
- By loading a program into the recorder that sends the required commands

See Appendix D, *SDI-12 Sensor Support (p. D-1)*, for detailed instructions.

7.2 Datalogger Programming

Short Cut is the best source for up-to-date datalogger programming code.

If your data acquisition requirements are simple, you can probably create and maintain a datalogger program exclusively with *Short Cut*. If your data acquisition needs are more complex, the files that *Short Cut* creates are a great source for programming code to start a new program or add to an existing custom program.

NOTE

Short Cut cannot edit programs after they are imported and edited in *CRBasic Editor*.

A *Short Cut* tutorial is available in Section 4, *QuickStart (p. 1)*. If you wish to import *Short Cut* code into *CRBasic Editor* to create or add to a customized program, follow the procedure in Appendix A, *Importing Short Cut Code Into CRBasic Editor (p. A-1)*. Programming basics for CRBasic dataloggers are provided in the following sections. Complete program examples for select dataloggers can be found in Appendix B, *Example Programs (p. B-1)*.

7.3 SDI12Recorder() Instruction

The **SDI12Recorder()** measurement instruction programs CRBasic dataloggers to measure the CS215 sensor. This instruction sends a request to the sensor to make a measurement and then retrieves the measurement from the sensor. See Section 8.1, *Sensor Measurement (p. 9)*, for more information.

For most CRBasic dataloggers, the **SDI12Recorder()** instruction has the following syntax:

```
SDI12Recorder(Destination, SDIPort, SDIAddress, "SDICommand",
Multiplier, Offset, FillNAN, WaitonTimeout)
```

The **Destination** parameter must be an array of length 2, with the first index for air temperature (in °C) and the second for relative humidity (as a percent).

Set **SDICommand** to "M!", "C!", or "R!" – see Section 8.1, *Sensor Measurement (p. 9)*, to determine which is best for your application.

FillNAN and **WaitonTimeout** are optional parameters (refer to CRBasic Help for more information).

7.4 Installation

Locate the sensor over an open, level area at least 9 m (EPA) in diameter. The surface should be covered by short grass or the natural earth surface where

grass does not grow. Sensors should be located at a distance of at least four times the height of any nearby obstruction and at least 30 m (EPA) from large, paved areas. Sensors should be protected from thermal radiation and adequately ventilated. Protect the filter at the top of the sensor from exposure to liquid water. The hydrophobic nature of the filter repels light rain, but driving rain can force itself into the pore structure of the filter and take time to dry out.

Standard measurement heights:

- 1.5 m (AASC)
- 1.25 to 2.0 m (WMO)
- 2.0 m (EPA)

See Section 10, *Attributions and References (p. 15)*, for a list of references that discuss temperature and relative humidity sensors.

When used in the field, the CS215 must be housed in a radiation shield. Typically, the 41303-5A or RAD06 six-plate solar radiation shield is used.

A 41003-5 or RAD10 ten-plate solar radiation shield can also house the CS215 sensor. Using a 10-plate shield will give slightly more accurate readings. The 41003-5 shield will require a special adapter. The RAD10 will not require any additional parts.

The white colour of these shields reflects solar radiation, and the louvered construction allows air to pass freely through, thereby keeping the probe at or near ambient temperature. The RAD06 and RAD10 use a double-louvered design that offers improved sensor protection from insect intrusion and driving rain and snow. In addition, the RAD06 and RAD10 shields have lower self-heating in bright sunlight combined with higher temperatures ($> 24\text{ }^{\circ}\text{C}$ ($75\text{ }^{\circ}\text{F}$)) and low wind speeds ($< 2\text{ m/s}$ (4.5 mph)), giving a better measurement.

Each of these solar radiation shields attaches to a crossarm, mast, or user-supplied pipe with a 2.5 to 5.3 cm (1.0 to 2.1 inch) outer diameter.

Tools required for installing a radiation shield to a tripod or tower include:

- 1/2-inch open-end wrench
- small screwdriver provided with datalogger
- small Phillips screwdriver
- UV-resistant cable ties
- small pair of diagonal-cutting pliers
- adjustable wrench with a minimum 1-7/8 inch jaw size

7.4.1 Installation in a 41303-5A or 41303-5B 6-Plate Shield

1. With a small Phillips screwdriver, loosen the plastic split collar at the base of the shield (reversing the removable portion if necessary), and gently insert the probe.
2. Tighten the screws on the collar until it firmly grips the probe body. See FIGURE 7-1 (left) and FIGURE 7-2.

7.4.2 Installation in a 41003-5 or 41003-5A 10-Plate Shield Using 6637 Collar Adapter

1. Loosely thread the collar adapter into the base of the 10-plate shield.
2. Insert the CS215 sensor through the collar as far as it will go.
3. Hold the collar and sensor, and finish threading the collar into the shield by hand. Tighten the collar around the sensor until it firmly grips the probe body. Use an adjustable wrench if necessary, but do not overtighten the collar.

7.4.3 Installation in a RAD06 6-Plate Shield or RAD10 10-Plate Shield

1. Loosen the nut on the entry gland at the bottom of the shield.
2. Insert the sensor into the gland as far as it will go (FIGURE 7-1 (right)).
3. Using an adjustable wrench, tighten the nut on the gland until the sensor is held firmly in place. Do not overtighten.

7.4.4 Mount the Shield

1. Attach the radiation shield to the tripod mast, crossarm, or tower leg using the supplied U-bolt or band clamp (FIGURE 7-1 and FIGURE 7-2).
2. Route the cable to the datalogger, and secure the cable to the mounting structure using cable ties.

CAUTION

Failure to secure the cable can lead to breakage of the wires due to fatigue caused by blowing back and forth in the wind.



FIGURE 7-1. CS215 and 41303-5A Radiation Shield (left) and RAD06 Radiation Shield (right) on a tripod mast



FIGURE 7-2. CS215 and 41303-5A Radiation Shield on a CM200 Series Crossarm

8. Operation

8.1 Sensor Measurement

The CS215 sensor responds to the **?!**, **M!**, **MC!**, **C!**, **CC!**, **R!**, and **RC!** SDI-12 commands. For the **?!** command, the sensor returns the SDI-12 address. For the other commands, the sensor returns two values: temperature in degrees Celsius and relative humidity as a percentage (0 to 100).

When using the **M!** command, the datalogger waits for the time specified by the sensor, sends the **D!** command, pauses its operation, and waits until either it receives the data from the sensor or the sensor timeout expires. If the datalogger receives no response, it will send the command a total of three times, with three retries for each attempt, or until a response is received. Because of the delays this command requires, it is only recommended in measurement scans of 10 seconds or more.

The **C!** command follows the same pattern as the **M!** command with the exception that it does not require the datalogger to pause its operation until the values are ready. Rather, the datalogger picks up the data with the **D!** command on the next pass through the program. Another measurement request is then sent so that data are ready on the next scan.

The **R!** command switches the sensor to automatically make measurements and send data every 11 seconds, ± 2 seconds, based on the internal clock of the sensor. If measurements are requested at 2 seconds or faster, the sensor will increase its measurement rate to approximately every 5 seconds. This instruction usually takes less than 300 milliseconds to execute. The automatic measurement mode can only be cancelled by powering down the sensor to reset it.

NOTE

Only CS215 sensors with serial numbers higher than E1587 or those with an upgraded operating system support the **R!** command.

The CS215 also supports the **MC!**, **CC!**, and **RC!** commands, which are the same as the instructions above, but where the C at the end of the instruction forces a validation for the data received from the sensor using a checksum. If the checksum is invalid, the datalogger will re-request the data up to three times. The checksum validation increases the measurement time by about 40 milliseconds if there are no errors. Retries will increase the measurement time in proportion to the number of retries. The checksum option is necessary only for long cable runs.

See Appendix D, *SDI-12 Sensor Support (p. D-1)*, for additional commands and details of the SDI-12 protocol.

8.2 Measurements at Fast Scan Rates

Using the **SlowSequence()** function allows the SDI-12 instruction to run as a background process, causing minimum interference to other measurements that use the analogue hardware. Measuring the sensor in a **SlowSequence()** section of the program allows faster programs to run as the main scan.

NOTE For the CR5000, use a control terminal rather than the SDI-12 terminal to allow the **SDI12recorder** instruction to run in the slow sequence.

8.3 Long Cables

Digital data transfer eliminates offset errors due to cable lengths. However, digital communications can break down when cables are too long, resulting in either no response from the sensor or corrupted readings. The original SDI-12 standard specifies the maximum total cable length to be 200 feet (61 metres). To ensure proper operation with long cables, follow these guidelines:

- Use low capacitance, low resistance, screened cable (as fitted by Campbell Scientific) to reach distances of several hundred metres.
- Ensure that the power ground cable has low resistance and is connected to the same ground reference as the datalogger control terminal.
- Be aware that “daisy-chaining” sensors reduces the maximum cable length roughly in proportion to the number of sensors connected in parallel.

8.4 Power Conservation

The CS215 draws less than 70 μA of current between measurements. In most applications this is insignificant compared to the datalogger and other power draws, so the sensor can be permanently connected.

In low-power applications, conserve battery power by turning the 12 V supply to the CS215 on just before the measurement (allowing a warm-up time of at least 100 ms) and then turning it off afterwards. If available, the switched 12 V output of the datalogger can be used.

8.5 Measuring Multiple SDI-12 Sensors

Multiple SDI-12 sensors can be connected to a single datalogger control terminal if they have unique SDI-12 addresses. The CS215 can have an SDI-12 address of 0 to 9. Some SDI-12 devices can have an SDI-12 address of 0 to 9, A to Z, or a to z. See Appendix [D.2.5, Change Address Command \(aAb!\)](#) (p. D-3), to change the CS215 SDI-12 address from its default address of 0.

9. Troubleshooting and Maintenance

NOTE

All factory repairs and recalibrations require a returned material authorization (RMA) and completion of the “Declaration of Hazardous Material and Decontamination” form. Refer to the [Assistance](#) page at the beginning of this manual for more information.

9.1 Troubleshooting

Symptom: Temperature is reported as **-9999** or **NAN**, and relative humidity is reported as **0** or as an unchanging value.

Recheck wiring. Verify the green wire is connected to the control terminal specified by the **SDI12Recorder()** instruction. Verify the red wire is connected to a 12V terminal.

Check the voltage to the sensor with a digital voltage meter. If a switched 12V terminal is used, temporarily connect the red wire to a 12V terminal (non-switched) for test purposes.

Verify the CS215 SDI-12 address matches the address entered for the **SDI12Recorder()** instruction. The default address is 0. The address can be verified or changed with the commands described in Appendix [D, SDI-12 Sensor Support](#) (p. D-1).

Remove the filter tip and verify that the sensing element has been installed with the proper orientation as described in Section [9.4, Sensor Element Replacement](#) (p. 12).

Symptom: Incorrect temperature or relative humidity is reported.

If using the SW12 terminal to power the sensor, verify the program is allowing a warm-up time of at least 100 ms.

Check to see if the filter tip has been contaminated. Replace the filter tip, or clean with distilled water as needed.

9.2 Maintenance

The CS215 probe requires minimal maintenance, but dust, debris, and salts on the filter cap will degrade sensor performance. Check the white filter on the end of the sensor for debris. If dirt or salt is ingrained in the filter, clean with distilled water or replace it. Make sure the filter is connected firmly with your fingers—do not over tighten

Check the radiation shield monthly to make sure it is free from dust and debris. To clean the shield, first remove the sensor. Dismount the shield. Brush all loose dirt off. If more effort is needed, use warm, soapy water and a soft cloth or brush to thoroughly clean the shield. Allow the shield to dry before remounting.

9.3 Calibration

The life of the humidity chip element is quoted as many years with a typical drift of less than 1% per year when used in 'clean' environments. Because it can be difficult to know what the sensor has been exposed to and because the element is relatively inexpensive, the sensor element is often replaced annually, which is the normal interval for recalibrating similar probes. Replacing the element should return the CS215 to factory calibration for temperature and relative humidity.

9.4 Sensor Element Replacement Procedure

1. Wash your hands to avoid getting dirt or grease on the element.

NOTE

Dirt, salt, or grease left on the plastic while handling the element may influence the measurements.

2. Disconnect the CS215 from the 12 V power supply.
3. Remove the filter by unscrewing it counterclockwise when looking towards the tip of the sensor.

CAUTION

The filter cap unscrews from the probe. Attempting to pull it off will destroy it.

4. Identify the sensor element. FIGURE 9-1 below shows a side view of the end of the probe and sensor element. Before removing the element, carefully study the probe, note its orientation, and read the following description:
 - The element plugs into the black plastic socket that protrudes by about 1 mm from the end of the metal body of the sensor.
 - Eight holes are in the socket, while the element only has four pins.
 - The element will work when fitted into either side of socket but must be installed in one of the two possible orientations to work.
 - The correct orientation is with the black moulded tip of the element (that contains the sensing components) mounted directly above the centre of the socket.
 - FIGURE 9-1 shows the correct orientation, while FIGURE 9-2 shows the incorrect orientation.

CAUTION

An incorrectly oriented element will not work, will draw excessive power, and may be damaged if left powered in this state for more than a few seconds.

5. Grasp the body of the sensor (this also ensures you are at the same electrical potential as the element) and, holding the black tip of the element between your fingertips, pull the element out of the socket. Store the old element in electrostatic protective packaging if you wish to retain it.
6. With the element removed, check for dirt and/or corrosion around the socket. Clean any dirt away using a damp cloth to remove any salts that might be there.
7. Unpack the replacement element, avoiding static discharges to the element by making sure you touch the packaging before the element.
8. Either hold the element by the black top of the package (the other end to the gold plated pins) or use a pair of fine nosed pliers or tweezers to grip the sensor by the pins. Carefully match the pins to the socket in the end of probe.
9. Confirm the correct orientation and gently push the pins into the socket until they will not go in any further.
10. Before replacing the filter element and turning on power to the sensor, double-check that the sensor is inserted in the correct orientation. Refer to [FIGURE 9-1](#).
11. Screw the filter back onto the end of the probe, making sure it clears the sensor element. If the element appears too close to the filter, it likely has been inserted in the incorrect orientation or the legs of the element have been bent. Screw the filter onto the thread and tighten gently with your fingers.

CAUTION

Only tighten the filter approximately an eighth of a turn by hand when the filter is fully screwed onto the thread. Over-tightening the filter will damage it and cause problems in inserting and removing the probe from some shields.

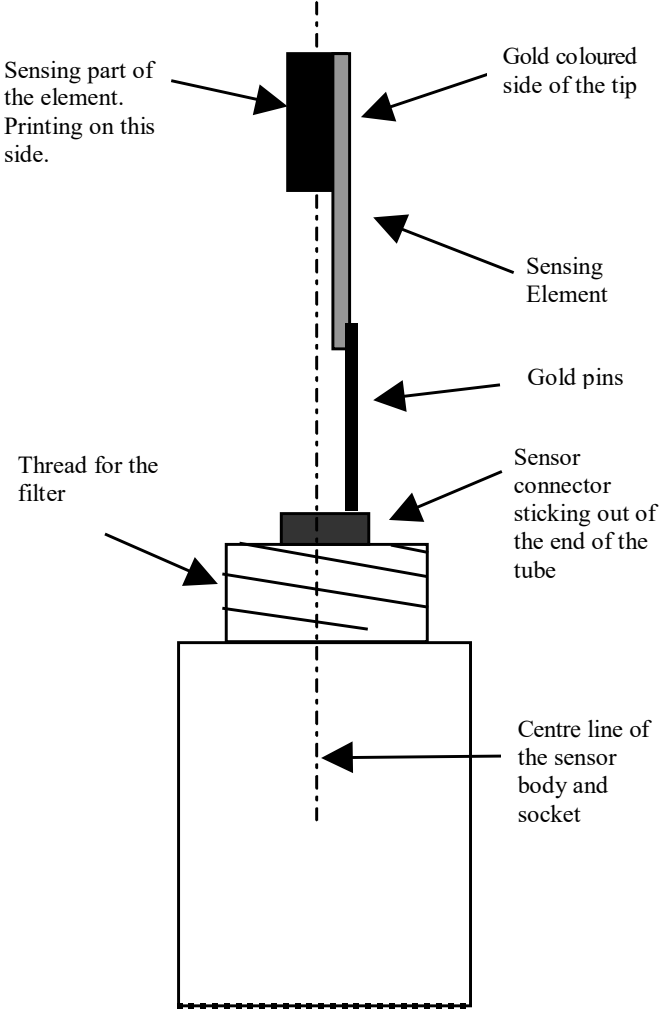

FIGURE 9-1. Correct fit of sensor element (side view)

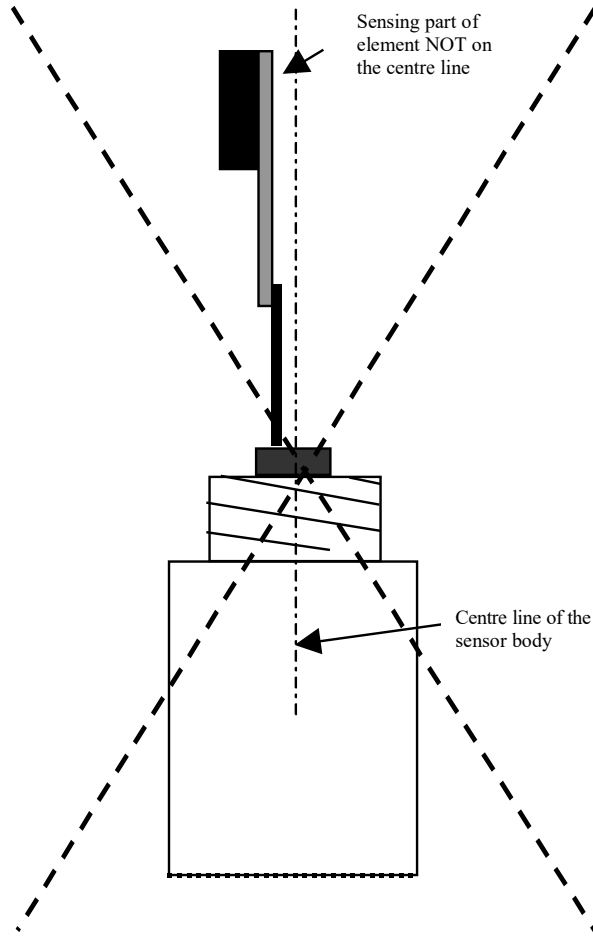

FIGURE 9-2. Incorrect fit of sensor element (side view)

10. Attributions and References

Santoprene® is a registered trademark of Exxon Mobile Corporation.

AASC, 1985: The State Climatologist (1985) Publication of the American Association of State Climatologists: *Heights and Exposure Standards for Sensors on Automated Weather Stations*, v. 9, No. 4 October, 1985. (www.stateclimate.org/sites/default/files/upload/pdf/state-climatologist/00000029.pdf)

EPA, 2008: *Quality Assurance Handbook for Air Pollution Measurement Systems*, Vol. IV, Meteorological Measurements, Ver. 2.0, EPA-454/B-08-002 (revised 2008). Office of Air Quality Planning and Standards, Research Triangle Park, NC 27711.

Goff, J. A. and S. Gratch, 1946: Low-pressure properties of water from -160° to 212°F, *Trans. Amer. Soc. Heat. Vent. Eng.*, **51**, 125-164.

Lowe, P. R., 1977: An approximating polynomial for the computation of saturation vapour pressure, *J. Appl. Meteor.*, **16**, 100-103.

Meyer, S. J. and K. G. Hubbard, 1992: Nonfederal Automated Weather Stations and Networks in the United States and Canada: A Preliminary Survey, *Bulletin Am. Meteor. Soc.*, **73**, No. 4, 449-457.

Weiss, A., 1977: Algorithms for the calculation of moist air properties on a hand calculator, *Amer. Soc. Ag. Eng.*, **20**, 1133-1136.

WMO, 2008. *Guide to Meteorological Instruments and Methods of Observation*. World Meteorological Organization No. 8, 7th edition, Geneva, Switzerland.

Appendix A. Importing Short Cut Code Into CRBasic Editor

This tutorial shows:

- How to import a *Short Cut* program into a program editor for additional refinement
- How to import a wiring diagram from *Short Cut* into the comments of a custom program

Short Cut creates files, which can be imported into *CRBasic Editor*. Assuming defaults were used when *Short Cut* was installed, these files reside in the C:\campbellsci\SCWin folder:

- .DEF (wiring and memory usage information)
- .CR2 (CR200(X)-series datalogger code)
- .CR300 (CR300-series datalogger code)
- .CR6 (CR6-series datalogger code)
- .CR8 (CR800-series datalogger code)
- .CR1 (CR1000 datalogger code)
- .CR1X (CR1000X-series datalogger code)
- .CR3 (CR3000 datalogger code)
- .CR5 (CR5000 datalogger code)

Use the following procedure to import *Short Cut* code and wiring diagram into *CRBasic Editor*.

1. Create the *Short Cut* program following the procedure in Section 4, *QuickStart* (p. 1). Finish the program. On the **Advanced** tab, click the **CRBasic Editor** button. The program opens in CRBasic with the name **noname.CR_**. Now save the program with your desired name in any folder.

NOTE

Once the file is edited with *CRBasic Editor*, *Short Cut* can no longer be used to edit the datalogger program. Change the name of the program file or move it, or *Short Cut* may overwrite it next time it is used.

2. The program can now be edited, saved, and sent to the datalogger.
3. Import wiring information to the program by opening the associated .DEF file. By default, it will be in the c:\campbellsci\SCWin folder. Copy and paste the section beginning with heading “–Wiring for CRXXX–” into the CRBasic program, usually at the head of the file. After pasting, edit the information such that an apostrophe (') begins each line. This character instructs the datalogger compiler to ignore the line when compiling. You can highlight several lines of CRBasic code then right-click and select **Comment Block**. (This feature is demonstrated at about 5:10 in the [CRBasic | Features](#) video.)

Appendix B. Example Programs

This CR1000X program can be adapted for use with CR300-, CR6-, and CR800-series, CR1000, CR3000, and CR5000 dataloggers.

CRBasic Example B-1. CR1000X Program for Measuring the CS215

```
'Program measures one CS215 sensor every 5 seconds and stores the average
'temperature and a sample of relative humidity every 10 minutes.

'Wiring Diagram
'=====
'CS215

' Wire
' Colour Function Datalogger
' -----
' Red Power (12V) 12V
' Green SDI-12 signal C7
' Black Power ground G
' White Power ground G
' Clear Shield G

'Declare the variable array for the measurement
Public TRHData(2)

Alias TRHData(1)=AirTC
Alias TRHData(2)=RH

Units AirTC=Deg C
Units RH=%

'Define Data Tables
DataTable(TenMin,True,-1)
DataInterval(0,10,Min,10)
Average(1,AirTC,FP2,False)
Sample(1,RH,FP2)
EndTable

'Main Program
BeginProg
'Main Scan
Scan(5,Sec,1,0)
'CS215 Temperature & Relative Humidity Sensor measurements 'AirTC' and 'RH'
SDI12Recorder(TRHData(),C7,"0","M!",1,0)
'Call Data Tables and Store Data
CallTable(TenMin)
NextScan
EndProg
```

This example program shows the measurement of a single CS215 and can be used directly with CR200(X) series dataloggers.

CRBasic Example B-2. CR200(X) Program for Measuring the CS215

```
'CR200(X) Series Datalogger
'Program measures one CS215 sensor every 30 seconds and stores the average
'temperature and a sample of relative humidity every 10 minutes.

'Wiring Diagram
'=====
'CS215

' Wire
' Colour  Function      CR200(X)
' -----  -
' Red     Power (12V)      Battery +
' Green   SDI-12 signal  C1/SDI-12
' Black   Power ground   G
' White   Power ground   G
' Clear   Shield        G

'Declare the variable array for the measurement
Public TRHData(2)

Alias TRHData(1)=AirTC
Alias TRHData(2)=RH

Units AirTC=Deg C
Units RH=%

'Define a data table for ten-minute data
DataTable(TenMin,True,-1)
  DataInterval(0,10,Min)
  Average(1,AirTC,False)
  Sample(1,RH)
EndTable

'Main Program
BeginProg
  Scan (30,Sec) 'Scan every 30 seconds
  'CS215 Temperature & Relative Humidity Sensor measurements 'AirTC' and 'RH'
  SDI12Recorder(TRHData(),"OM!",1,0)
  'Call Data Tables and Store Data
  CallTable TenMin
  NextScan
EndProg
```

Appendix C. Environmental Performance

This Appendix details tests and limitations of the sensor when exposed to extremes of the environment.

C.1 Tests to Defined Standards

The sensor element has been tested by the manufacturer and found to comply with various environmental test standards as shown in TABLE C-1 below:

TABLE C-1. Environmental Tests		
Environment	Norm	Results
Temperature Cycles	JESD22-A104-B -40/+125 °C, 1000 cycles	Within Specifications
HAST Pressure Cooker	JESD22-A110-B 2.3bar 125 °C 85% RH	Reversible shift by +2% RH
Salt Atmosphere	DIN-50021SS	Within Specifications
Condensing Air	–	Within Specifications
Freezing cycles Fully Submerged	-20/+90 °C, 100 cycles, 30 min dwell time	Reversible shift by +2% RH
Various Automotive Chemicals	DIN 72300-5	Within Specifications
Cigarette Smoke	Equivalent to 15years in a mid-size car	Within Specifications

N.B. The temperature sensor passed all tests without any detectable drift. Package and electronics also passed 100%

C.2 Exposure to Pollutants

All capacitive sensors are susceptible to pollutants to some degree. The vapours may interfere with the polymer layers used in the structure of the sensing element. The diffusion of chemicals into the polymer may cause temporary or even permanent shifts in both offset and sensitivity.

After low levels of exposure, in a clean environment the contaminants will slowly outgas and the sensor recovers. High levels of pollutants may cause permanent damage to the sensing polymer.

As a general rule, the sensor will not be damaged by levels of chemicals which are not too dangerous to human health (see TABLE C-1), so damage is not normally a problem in outdoor applications. Avoid exposing the sensor to chemicals at higher concentrations.

C.3 Operating Range of RH Element

The RH sensor is specified to work over the entire humidity range of 0–100% RH for the temperature range –20 to 60 °C. It will give readings over an extended range as shown in FIGURE C-1 below (although the electronics of the CS215 probe are not specified to operate beyond 70 °C).

When used outside the range of normal conditions or when subject to prolonged periods of condensation or freezing, the sensor calibration may be temporarily altered, normally resulting in a change of <+3% RH. Upon returning to normal conditions, the calibration will settle back to the “standard” calibration over the course of several days. In laboratory conditions, it is possible to speed up this process by a reconditioning process, as follows: 80–90 °C at < 5 %RH for 24 h (baking) followed by 20–30 °C at > 74% RH for 48 h (re-hydration).

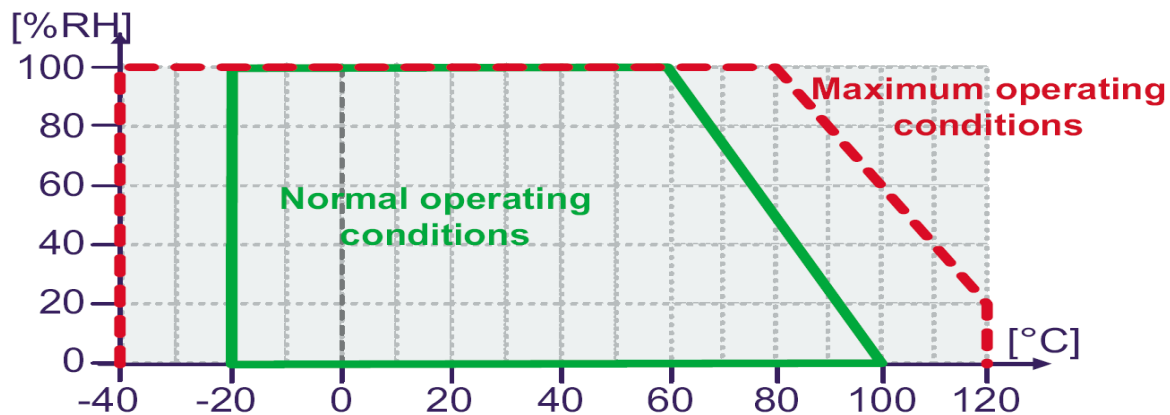

FIGURE C-1. Normal operating conditions of RH element

C.4 Measurement Below 0 °C

The CS215 provides a humidity reading that is referenced to the saturated water vapour pressure above liquid water, even at temperatures below 0 °C, where ice might form. This is the common way to express relative humidity and is as defined by the World Meteorological Organization. If an RH value is required to be referenced to ice, the CS215 readings will need to be corrected.

One consequence of using water as the reference is that the maximum humidity that will normally be output by the sensor for temperatures below freezing is as follows:

100% RH at 0 °C
 95% RH at –5 °C
 91% RH at –10 °C
 87% RH at –15 °C
 82% RH at –20 °C
 78% RH at –25 °C
 75% RH at –30 °C

In practical terms this means that, for instance, at –20 °C the air is effectively fully saturated when the sensor outputs 82% RH.

Appendix D. SDI-12 Sensor Support

D.1 Introduction

SDI-12, Serial Data Interface at 1200 baud, is a protocol developed to simplify sensor and datalogger compatibility. Only three wires are necessary — serial data, ground, and 12 V. With unique addresses, multiple SDI-12 sensors can connect to a single SDI-12 terminal on a Campbell Scientific datalogger.

This appendix discusses the structure of SDI-12 commands and the process of querying SDI-12 sensors. For more detailed information, refer to version 1.4 of the SDI-12 protocol, available at www.sdi-12.org.

For additional information, refer to the [SDI-12 Sensors | Transparent Mode](#) and [SDI-12 Sensors | Watch or Sniffer Mode](#) videos.

D.2 SDI-12 Command Basics

SDI-12 commands have three components:

Sensor address (a) – a single character and the first character of the command. The default address of zero (0) can be used unless multiple sensors are connected to the same port.

Command body – an upper case letter (the “command”), optionally followed by one or more alphanumeric qualifiers.

Command termination (!) – an exclamation mark.

An active sensor responds to each command. Responses have several standard forms and always terminate with <CR><LF> (carriage return and line feed). Standard SDI-12 commands are listed in TABLE D-1.

Name	Command	Response¹
Acknowledge Active	a!	a<CR><LF>
Send Identification	aI!	allccccccmmmmmmvvvxxx...xx <CR><LF>
Start Verification	aV!	atttn <CR><LF>
Address Query	?!	a<CR><LF>
Change Address	aAb!	b<CR><LF>
Start Measurement	aM! aM1!...aM9!	atttn<CR><LF>
Start Measurement and Request CRC	aMC! aMC1!...aMC9!	atttn <CR><LF>

TABLE D-1. Campbell Scientific Sensor SDI-12 Command and Response Set		
Name	Command	Response ¹
Start Concurrent Measurement	aC! aC1!...aC9!	attnn<CR><LF>
Start Concurrent Measurement and Request CRC	aCC! aCC1!...aCC9!	attnn<CR><LF>
Send Data	aD0!...aD9!	a<values><CR><LF> or a<values><CRC><CR><LF>
Continuous Measurement	aR0!...aR9!	a<values><CR><LF>
Continuous Measurement and Request CRC	aRC0!...aRC9!	a<values><CRC><CR><LF>
¹ Information on each of these commands is given in following sections.		

D.2.1 Acknowledge Active Command (a!)

The Acknowledge Active command (a!) is used to test a sensor on the SDI-12 bus. An active sensor responds with its address.

D.2.2 Send Identification Command (a!)

Sensor identifiers are requested by issuing command a!. The reply is defined by the sensor manufacturer but usually includes the sensor address, SDI-12 version, manufacturer’s name, and sensor model information. Serial number or other sensor specific information may also be included.

a!	allccccccmmmmmmvfvxxx...xx<CR><LF>
a	Sensor SDI-12 address
ll	SDI-12 version number (indicates compatibility)
cccccc	8-character vendor identification
mmmmmm	6 characters specifying the sensor model
vfv	3 characters specifying the sensor version (OS)
xxx...xx	An optional field up to 13 characters in length, used for a serial number or other specific sensor information that is not relevant for operation of the datalogger
<CR><LF>	Terminates the response.
Source: <i>SDI-12: A Serial-Digital Interface Standard for Microprocessor-Based Sensors</i> (see Appendix D.4, References (p. D-9)).	

D.2.3 Start Verification Command (aV!)

The response to a Start Verification command may include hardware diagnostics, but like the **aI!** command, the response is not standardized.

Command: **aV!**

Response: *attn*<CR><LF>

a = sensor address

ttn = time, in seconds, until verification information is available

n = the number of values to be returned when one or more subsequent **D!** commands are issued

D.2.4 Address Query Command (?!)

Command **?!** requests the address of the connected sensor. The sensor replies to the query with the address, *a*. This command should only be used with one sensor on the SDI-12 bus at a time.

D.2.5 Change Address Command (aAb!)

Multiple SDI-12 sensors can be connected to a single SDI-12 terminal on a datalogger. Each device on a single terminal must have a unique address.

A sensor address is changed with command **aAb!**, where *a* is the current address and *b* is the new address. For example, to change an address from 0 to 2, the command is **0A2!**. The sensor responds with the new address *b*, which in this case is 2.

D.2.6 Start Measurement Commands (aM!)

A measurement is initiated with the **M!** command. The response to each command has the form *attn*<CR><LF>, where

a = sensor address

ttn = time, in seconds, until measurement data are available. If the data is ready before then, the sensor notifies the datalogger, and the datalogger begins issuing **D** commands.

n = the number of values to be returned when one or more subsequent **D** commands are issued. For the **aM!** command, *n* is an integer from 0 to 9.

When the aM! is issued, the datalogger pauses its operation and waits until either it receives the data from the sensor or the time, *ttn*, expires.

Depending on the scan interval of the datalogger program and the response time of the sensor, this may cause skipped scans to occur. In this case make sure your scan interval is longer than the longest measurement time (*ttn*).

TABLE D-2. Example aM! Sequence	
0M!	The datalogger makes a request to sensor 0 to start a measurement.
00352<CR><LF>	Sensor 0 immediately indicates that it will return 2 values within the next 35 seconds.
0<CR><LF>	Within 35 seconds, sensor 0 indicates that it has completed the measurement by sending a service request to the datalogger.
0D0!	The datalogger immediately issues the first D command to collect data from the sensor.
0+.859+3.54<CR><LF>	The sensor immediately responds with the sensor address and the two values.

D.2.7 Start Concurrent Measurement Commands (aC!)

A concurrent measurement (**aC!**) command follows the same pattern as the **aM!** command with the exception that it does not require the datalogger to pause its operation, and other SDI-12 sensors may take measurements at the same time. The sensor will not issue a service request to notify the datalogger that the measurement is complete. The datalogger will issue the **aD0!** command during the next scan after the measurement time reported by the sensor has expired. To use this command, the scan interval should be 10 seconds or less. The response to each command has the form *atttn*<CR><LF>, where

a = the sensor address

ttt = time, in seconds, until the measurement data are available

nn = the number of values to be returned when one or more subsequent **D** commands are issued.

See the following example. A datalogger has three sensors wired into terminal **C1**. The sensors are addresses X, Y, and Z. The datalogger will issue the following commands and receive the following responses:

TABLE D-3. Example aC! Sequence	
XC!	The datalogger makes a request to sensor X to start a concurrent measurement.
X03005<CR><LF>	Sensor X immediately indicates that it will have 5 (05) values ready for collection within the next 30 (030) seconds.
YC!	The datalogger makes a request to sensor Y to start a concurrent measurement.
Y04006<CR><LF>	Sensor Y immediately indicates that it will have 6 (06) values ready for collection within the next 40 (040) seconds.
ZC!	The datalogger makes a request to sensor Z to start a concurrent measurement.
Z02010<CR><LF>	Sensor Z immediately indicates that it will have 10 values ready for collection within the next 20 (020) seconds.
ZD0!	After 20 seconds have passed, the datalogger starts the process of collecting the data by issuing the first D command to sensor Z.
Z+1+2+3+4+5+6+7+8+9+10<CR><LF>	Sensor Z immediately responds with the sensor address and the 10 values.
XD0!	10 seconds later, after a total of 30 seconds have passed, the datalogger starts the process of data from sensor X by issuing the first D command.
X+1+2+3+4+5<CR><LF>	The sensor immediately responds with the sensor address and the 5 values.
YD0!	Ten seconds later, after a total of 40 seconds have passed, the datalogger starts the process of data from sensor Y by issuing the first D command.
Y+1+2+3+4+5+6<CR><LF>	The sensor immediately responds with the sensor address and the 6 values.

D.2.8 Start Measurement Commands with Cyclic Redundancy Check (aMC! and aCC!)

Error checking is done by using measurement commands with cyclic redundancy checks (**aMC!** or **aCC!**). This is most commonly implemented when long cable lengths or electronic noise may impact measurement transmission to the datalogger. When these commands are used, the data returned in response to **D** or **R** commands must have a cyclic redundancy check (CRC) code appended to it. The CRC code is a 16-bit value encoded within 3 characters appended before the <CR><LF>. This code will not be returned in the data table but checked by the datalogger as it comes. The code returned is based on the SDI-12 protocol. See the SDI-12 communication specification for version 1.3 available at www.sdi-12.org to learn more about how the CRC code is developed.

D.2.9 Stopping a Measurement Command

A measurement command (**M!**) is stopped if it detects a break signal. A break signal is sent by the datalogger before most commands.

A concurrent measurement command (**C!**) is aborted when any other valid command is sent to the sensor before the measurement time has elapsed.

D.2.10 Send Data Command (aD0! ... aD9!)

The Send Data command requests data from the sensor. It is issued automatically with every type of measurement command (**aM!**, **aMC!**, **aC!**, **aCC!**). When the measurement command is **aM!** or **aMC!**, the datalogger issues the **aD0!** command once a service request has been received from the sensor. When the datalogger is issuing concurrent commands (**aC!** or **aCC!**), the Send Data command is issued after the required time has elapsed (no service request will be sent by the sensor). In transparent mode (Appendix D.3, *SDI-12 Transparent Mode (p. D-7)*), the user asserts this command to obtain data.

Depending on the type of data returned and the number of values a sensor returns, the datalogger may need to issue **aD0!** up to **aD9!** to retrieve all data. A sensor may return up to 35 characters of data in response to a **D** command that follows an **M!** or **MC!** command. A sensor may return up to 75 characters of data in response to a **D** command that follows a **C!** or **CC!** command.

Command: **aD0! (aD1! ... aD9!)**

Response: *a*<values><CR><LF> or
a<values><CRC><CR><LF>

where:

a = the sensor address

<values> = values returned with a polarity sign (+ or -)

<CR><LF> = terminates the response

<CRC> = 16-bit CRC code appended if data was requested with **aMC!** or **aCC!**.

D.2.11 Continuous Measurement Command (aR0! ... aR9!)

Sensors that are able to continuously monitor the phenomena to be measured can be read directly with the **R** commands (**R0!...R9!**). The response to the **R** commands mirrors the Send Data command (**aD0!**). A maximum of 75 characters can be returned in the *<values>* part of the response to the **R** command.

D.3 SDI-12 Transparent Mode

System operators can manually interrogate and enter settings in probes using transparent mode. Transparent mode is useful in troubleshooting SDI-12 systems because it allows direct communication with probes. Datalogger security may need to be unlocked before transparent mode can be activated.

Transparent mode is entered while the computer is communicating with the datalogger through a terminal emulator program. It is accessed through Campbell Scientific datalogger support software or other terminal emulator programs. Datalogger keyboards and displays cannot be used.

The terminal emulator is accessed by navigating to the **Datalogger** menu in *PC200W*, the **Tools** menu in *PC400*, or the **Datalogger** menu in the *Connect* screen of *LoggerNet*.



Watch the video: [SDI-12 Sensors | Transparent Mode](#).

The following examples show how to enter transparent mode and change the SDI-12 address of an SDI-12 sensor. The steps shown in Appendix D.3.1, *Changing an SDI-12 Address* (p. D-7), are used with most Campbell Scientific dataloggers. Appendix D.3.2, *Changing an SDI-12 Address – CR200(X) Series* (p. D-8), lists the steps used for CR200(X)-series dataloggers.

D.3.1 Changing an SDI-12 Address

The example below was done with a CR1000, but the steps are only slightly different for CR1000X-series, CR300-series, CR6-series, CR800-series, and CR3000 dataloggers. For CR200(X)-series dataloggers, see Appendix D.3.2, *Changing an SDI-12 Address – CR200(X) Series* (p. D-8).

1. Connect an SDI-12 sensor to the CR1000.
2. In *LoggerNet Connect*, in the **Datalogger** menu, click **Terminal Emulator**. The terminal emulator window opens.
3. In the **Select Device** menu located in the lower left side of the window, select the **CR1000** station.
4. Click **Open Terminal**.
5. Select **All Caps Mode**.
6. Press Enter until the datalogger responds with the *CR1000>* prompt.
7. Type **SDI12** and press Enter.

8. At the *Select SDI12 Port* prompt, type the number corresponding to the control port where the sensor is connected and press Enter. The response *Entering SDI12 Terminal* indicates that the sensor is ready to accept SDI-12 commands.
9. To query the sensor for its current SDI-12 address, type **?!** and press Enter. The sensor responds with its SDI-12 address. If no characters are typed within 60 seconds, the mode is exited. In that case, simply type **SDI12** again, press Enter, and type the correct control port number when prompted.
10. To change the SDI-12 address, type **aAb!**, where *a* is the current address from the above step and *b* is the new address (see FIGURE D-1). Press Enter. The sensor will change its address and respond with the new address.
11. To exit SDI-12 transparent mode, click **Close Terminal**.

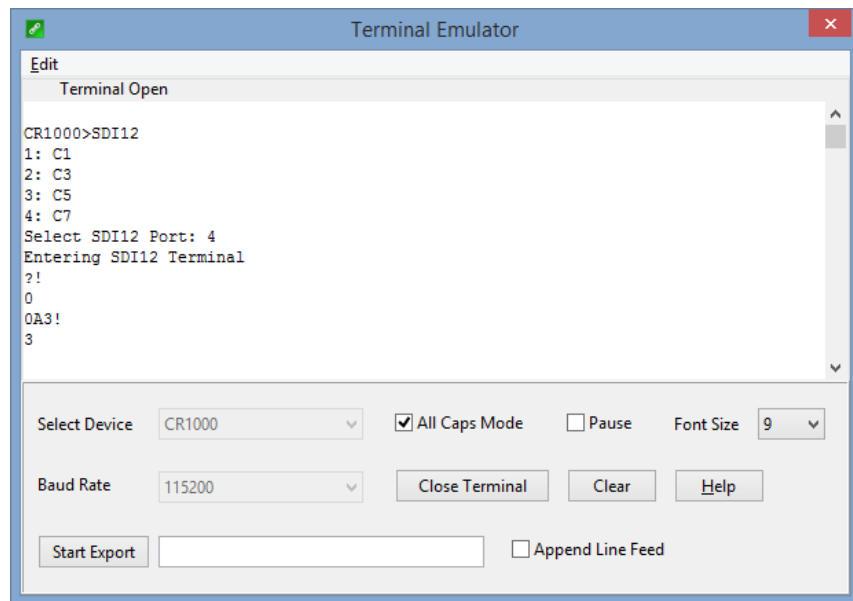

FIGURE D-1. CR1000 example of using the SDI-12 transparent mode to change the SDI-12 address from 0 to 3. Sensor is connected to control port 1.

D.3.2 Changing an SDI-12 Address – CR200(X) Series

1. Connect a single SDI-12 sensor to the CR200(X).
2. In *LoggerNet Connect*, in the **Datalogger** menu, click **Terminal Emulator**. The terminal emulator window opens.
3. In the **Select Device** menu located in the lower left side of the window, select the **CR200Series** station.
4. Click **Open Terminal**.

5. Select **All Caps Mode**.
6. Press Enter until the datalogger responds with the *CR2XX>* prompt.
7. Type **SDI12** and press Enter.
8. The response *SDI12>* indicates that the sensor is ready to accept SDI-12 commands.
9. To query the sensor for its current SDI-12 address, type **?!** and press Enter. The sensor responds with its SDI-12 address. If no characters are typed within 60 seconds, the mode is exited. In that case, simply type **SDI12** again and press Enter.
10. To change the SDI-12 address, type **aAb!**, where *a* is the current address from the above step and *b* is the new address (see FIGURE D-1). Press Enter. The sensor will change its address and respond with the new address.
11. To exit SDI-12 transparent mode, click **Close Terminal**.

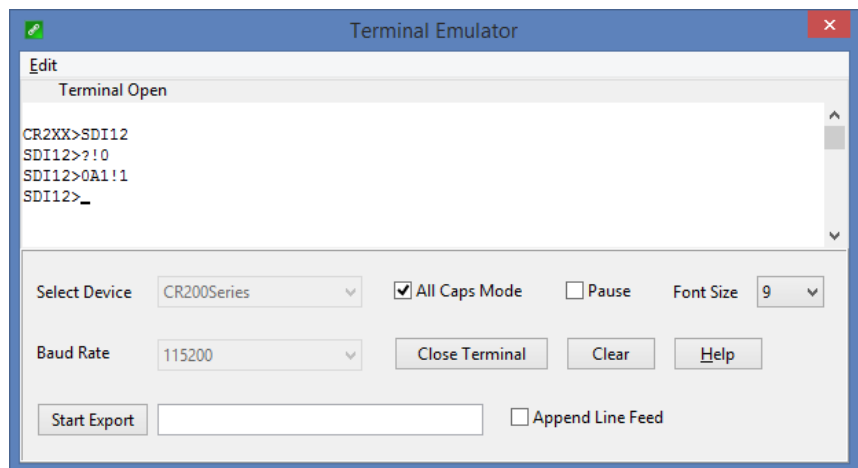

FIGURE D-2. CR200(X) example of using the SDI-12 transparent mode to change the SDI-12 address from 0 to 1

D.4 References

SDI-12 Support Group. *SDI-12: A Serial-Digital Interface Standard for Microprocessor-Based Sensors – Version 1.4*. River Heights, UT: SDI-12 Support Group, 2017. www.sdi-12.org/specification.php?file_id=1.

Campbell Scientific Worldwide Offices

Australia

Location: Garbutt, QLD Australia
Email: info@campbellsci.com.au
Website: www.campbellsci.com.au

Brazil

Location: São Paulo, SP Brazil
Email: andread@campbellsci.com.br
Website: www.campbellsci.com.br

Canada

Location: Edmonton, AB Canada
Email: dataloggers@campbellsci.ca
Website: www.campbellsci.ca

China

Location: Beijing, P. R. China
Email: info@campbellsci.com.cn
Website: www.campbellsci.com.cn

Costa Rica

Location: San José, Costa Rica
Email: info@campbellsci.cc
Website: www.campbellsci.cc

France

Location: Antony, France
Email: info@campbellsci.fr
Website: www.campbellsci.fr

Germany

Location: Bremen, Germany
Email: info@campbellsci.de
Website: www.campbellsci.de

South Africa

Location: Stellenbosch, South Africa
Email: sales@csafrica.co.za
Website: www.campbellscientific.co.za

Southeast Asia

Location: Bangkok, Thailand
Email: info@campbellsci.asia
Website: www.campbellsci.asia

Spain

Location: Barcelona, Spain
Email: info@campbellsci.es
Website: www.campbellsci.es

UK

Location: Shepshed, Loughborough, UK
Email: sales@campbellsci.co.uk
Website: www.campbellsci.co.uk

USA

Location: Logan, UT USA
Email: info@campbellsci.com
Website: www.campbellsci.com

Please visit www.campbellsci.com/contact to obtain contact information for your local US or international representative.