

***PWC100
Present Weather Sensor
Calibrator***

User Guide

Issued 6.2.12

Copyright © 2008-2012 Campbell Scientific Ltd.

CSL 801

Guarantee

This equipment is guaranteed against defects in materials and workmanship. This guarantee applies for twelve months from date of delivery. We will repair or replace products which prove to be defective during the guarantee period provided they are returned to us prepaid. The guarantee will not apply to:

- Equipment which has been modified or altered in any way without the written permission of Campbell Scientific
- Batteries
- Any product which has been subjected to misuse, neglect, acts of God or damage in transit.

Campbell Scientific will return guaranteed equipment by surface carrier prepaid. Campbell Scientific will not reimburse the claimant for costs incurred in removing and/or reinstalling equipment. This guarantee and the Company's obligation thereunder is in lieu of all other guarantees, expressed or implied, including those of suitability and fitness for a particular purpose. Campbell Scientific is not liable for consequential damage.

Please inform us before returning equipment and obtain a Repair Reference Number whether the repair is under guarantee or not. Please state the faults as clearly as possible, and if the product is out of the guarantee period it should be accompanied by a purchase order. Quotations for repairs can be given on request. It is the policy of Campbell Scientific to protect the health of its employees and provide a safe working environment, in support of this policy a "Declaration of Hazardous Material and Decontamination" form will be issued for completion.

When returning equipment, the Repair Reference Number must be clearly marked on the outside of the package. Complete the "Declaration of Hazardous Material and Decontamination" form and ensure a completed copy is returned with your goods. Please note your Repair may not be processed if you do not include a copy of this form and Campbell Scientific Ltd reserves the right to return goods at the customers' expense.

Note that goods sent air freight are subject to Customs clearance fees which Campbell Scientific will charge to customers. In many cases, these charges are greater than the cost of the repair.



Campbell Scientific Ltd,
Campbell Park, 80 Hathern Road,
Shepshed, Loughborough, LE12 9GX, UK
Tel: +44 (0) 1509 601141
Fax: +44 (0) 1509 601091

Email: support@campbellsci.co.uk
www.campbellsci.co.uk

PLEASE READ FIRST

About this manual

Please note that this manual was originally produced by Campbell Scientific Inc. primarily for the North American market. Some spellings, weights and measures may reflect this origin.

Some useful conversion factors:

Area: 1 in ² (square inch) = 645 mm ²	Mass: 1 oz. (ounce) = 28.35 g 1 lb (pound weight) = 0.454 kg
Length: 1 in. (inch) = 25.4 mm 1 ft (foot) = 304.8 mm 1 yard = 0.914 m 1 mile = 1.609 km	Pressure: 1 psi (lb/in ²) = 68.95 mb Volume: 1 UK pint = 568.3 ml 1 UK gallon = 4.546 litres 1 US gallon = 3.785 litres

In addition, while most of the information in the manual is correct for all countries, certain information is specific to the North American market and so may not be applicable to European users.

Differences include the U.S standard external power supply details where some information (for example the AC transformer input voltage) will not be applicable for British/European use. *Please note, however, that when a power supply adapter is ordered it will be suitable for use in your country.*

Reference to some radio transmitters, digital cell phones and aerials may also not be applicable according to your locality.

Some brackets, shields and enclosure options, including wiring, are not sold as standard items in the European market; in some cases alternatives are offered. Details of the alternatives will be covered in separate manuals.

Part numbers prefixed with a “#” symbol are special order parts for use with non-EU variants or for special installations. Please quote the full part number with the # when ordering.

Recycling information



At the end of this product's life it should not be put in commercial or domestic refuse but sent for recycling. Any batteries contained within the product or used during the products life should be removed from the product and also be sent to an appropriate recycling facility.

Campbell Scientific Ltd can advise on the recycling of the equipment and in some cases arrange collection and the correct disposal of it, although charges may apply for some items or territories.

For further advice or support, please contact Campbell Scientific Ltd, or your local agent.



Campbell Scientific Ltd, Campbell Park, 80 Hathern Road, Shepshed, Loughborough, LE12 9GX, UK
Tel: +44 (0) 1509 601141 Fax: +44 (0) 1509 601091
Email: support@campbellsci.co.uk
www.campbellsci.co.uk

Contents

1.	Introduction	1
2.	Operation and use	1
	2.1 Operating guidelines	1
	2.2 Initial configuration of the PWS100 for use of the calibrator	2
3.	PWS calibration.....	2
	3.1 Installing and connecting up the calibrator	3
	3.2 Starting the tests.....	3
4.	Cleaning guide	10
5.	Calibrator safety guidelines	10
6.	Electrical parameters.....	11
	6.1 PWC-100 voltages and currents	11
	6.2 Earth, 0V and transient protection.....	11

Appendix

A. Assembly guidelines

A1. Assembly guidelines	A-1
A2. Connector pin outs	A-2

Figures

A1a. Attaching the velocity disk	A-1
A1b. Attaching the visibility disk.....	A-1
A2. Attachment of the visibility calibrator.....	A-2

PWC100 Present Weather Sensor Calibrator

1. Introduction

The PWC100 is a customer field calibration validation device for the PWS100.

The PWC100 Calibrator system simulates particle and visibility data for the PWS100 allowing verification of the calibration constants held within the system.

The following features are checked by the calibrator:

- Particle velocity
- Particle size detection
- Laser beam uniformity
- Visibility range
- Component ageing.

The PWC100 will give a “go/no go” indication of the PWS100 calibration, to show whether the instrument is within normal operating limits. If required the PWC100 can be used to partially recalibrate the PWS100. That method is not described in this manual. Please contact Campbell Scientific for more details or refer to the PWS100 manual.

2. Operation and use

2.1 Operating guidelines

Please ensure that there are no obstructions between the PWS sensor heads before the tests are started.

The test should not be performed in the following conditions:

- Do not perform the calibration when it is raining or during any other precipitation event, such as snow, hail or drizzle.
- Do not perform the calibration when the local visibility is below approximately 10,000 metres.
- Do not perform the calibration if there is a strong wind that could blow debris into the sensing volume of the PWS.

Ambient temperature should be 20°C +/-10°C.

The PWC100 is not suitable for long term outdoor use and is only designed to be exposed for the duration of the calibration test. Long term exposure to outdoor environmental conditions may cause damage to the unit.

Care must be taken not to drop or scratch either the velocity or visibility units as this may cause errors that could result in tests failing when they shouldn't.

2.2 Initial configuration of the PWS100 for use of the calibrator

The visibility calibration discs provided as part of the calibration kit are individually calibrated and have a number printed on them to indicate the measured signal in a reference instrument. Each PWS100 that is to be used with the calibrator has to have that value entered into its configuration so that it is referenced to the properties of that disc. Once set the PWS100 will retain the calibrator disc information unless the sensor is reset to its factory defaults. The test procedure outlined in the rest of the manual can then be followed repeatedly without changing the settings in the sensors.

For information on how to set calibration disc constants, please refer to section 4.4.3 of the PWS100 manual. The screen in which the values are set is shown below. Please note you only need to change the constants, do not attempt to adjust the calibration of the PWS100 if carrying out the standard test procedure.

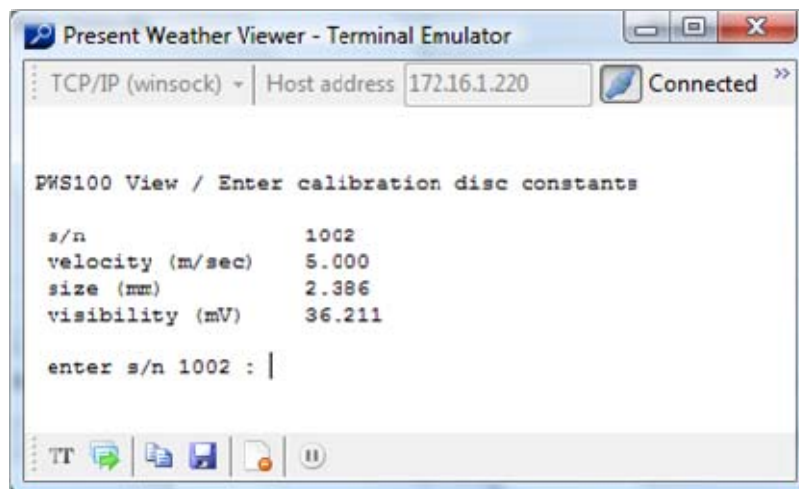

For normal operation it is only necessary to set the visibility constant, as printed on the disc. It is also useful to set the calibrator serial number for reference purposes. The velocity and size constants can be left at the factory defaults of 5.000 and 2.386 as these are fixed values for a standard calibrator.

3. PWS calibration

The calibration check procedure can be broken up into two separate sections. The first section comprises visibility tests and the second velocity tests. If only a visibility test is required then the tests can be finished after the first stage and the velocity tests need not be run.

It may be desirable to carry out a check of the sensor before and after cleaning the lenses of the sensor to determine if the previous readings of the sensor were adversely affected by dirt. This would be at the customers discretion.

3.1 Installing and connecting up the calibrator

- Remove the existing plastic blanking screws from their positions on the PWS centre block.
- Fix the PWC100 visibility calibrator unit to the centre position on the PWS using the two metal countersunk fixing screws provided.

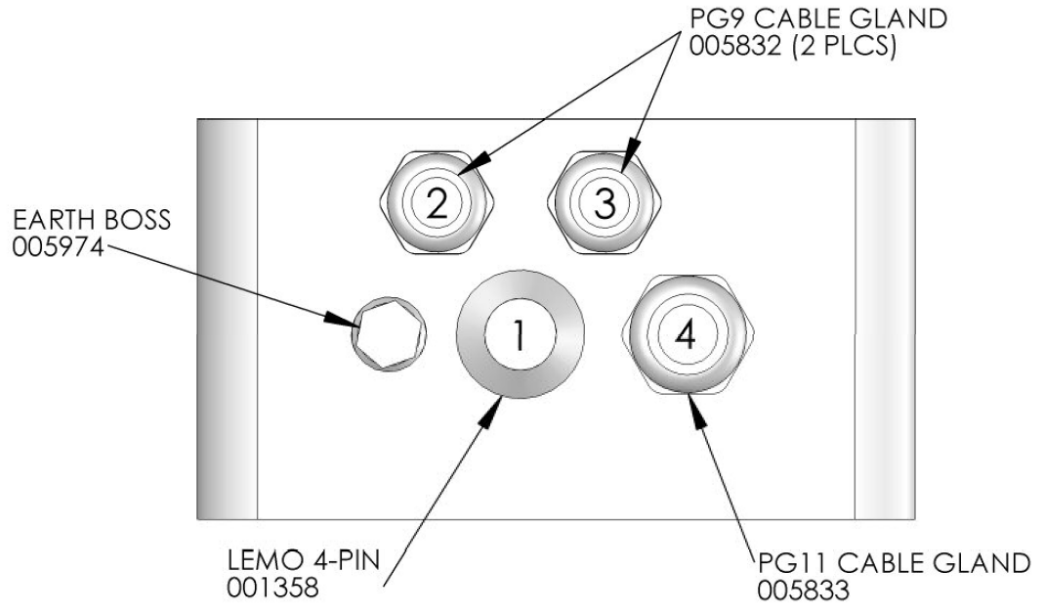

The PWS100 enclosure showing the LEMO connector used by the calibrator

3.2 Starting the tests

All PWC100 tests can be performed without the need to access the PWS with a PC. Only once the tests are finished and if changes to the calibration constants are needed, will a PC be required to change the system configuration.

If at any point you see a confirmation of LED's that you do not expect check the LED status table at the end of this section.

Step 1: Performing the visibility calibration

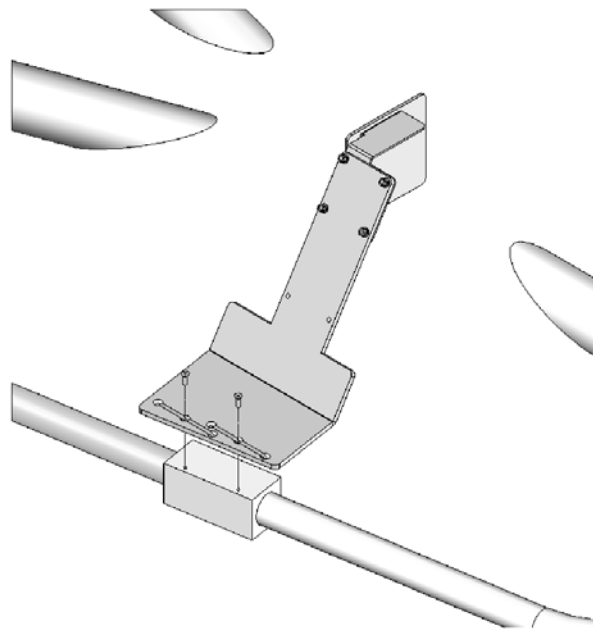

- Check that the PWC100 visibility calibrator unit is located correctly and securely (refer to Appendix A for additional details)
- Connect the LEMO connector coming from the velocity unit to the LEMO socket on the PWS (as detailed in Section 3.1). This will let the PWS know you want to start the tests. Press the 'RESET/STOP' button on the calibrator unit. Within 10 seconds all three LEDs should light up for approximately 3 seconds. This indicates that the calibration unit has been detected correctly by the PWS100 and that the LEDs are functioning correctly.
- LEDs 'L' and 'R' should now be flashing slowly and LED 'C' should be off
- Once you are ready, press 'START'
- The test is now automated. LED 'L' and 'R' will stay illuminated permanently until this stage of the test is complete. This test will take approximately two minutes.
- Upon successful completion of the test LED 'L' and LED 'C' will be flashing slowly, indicating that the next test is ready to be started.

Step 2: Performing the visibility maximum limit check

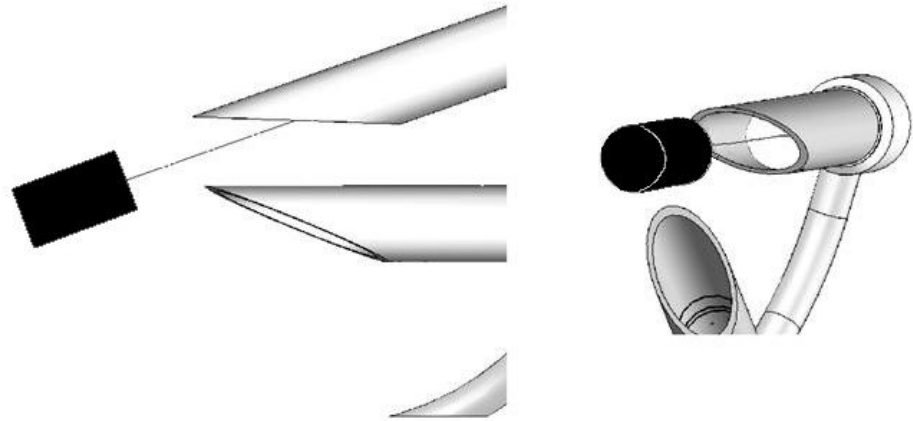

- Remove the PWC100 visibility calibration disk and place it back into its box
- Place the blanking plug into upper sensor head as shown in diagram above
- At this point LED 'L' and LED 'C' should be flashing slowly
- Once you are ready, press 'START'
- LED 'L' and LED 'C' will be illuminated for the duration of the test. This test will take approximately two minutes
- Upon successful completion of the test LED 'C' will be flashing slowly. This indicates the end of the visibility test
- Remember to remove the blanking plug from the PWS before continuing. *(This is important!)*

At this point steps three through five can be ignored if only the visibility calibrations are required.

To view the visibility test results alone press the 'RESET/STOP' button, this will jump the unit to the end of the tests and will display the results in the normal way detailed at the end of the calibration section (this is the only stage in the tests where pressing the 'RESET/STOP' button will not restart the tests).

Please remember to read the final section relating to tidying up and ensuring all screws and fasteners are returned to their original positions.

Step 3: Position 1: Centre position

Attaching the velocity calibration unit

- Fix the PWC100 velocity calibrator unit to the centre position on the PWS using the two countersunk fixing screws provided

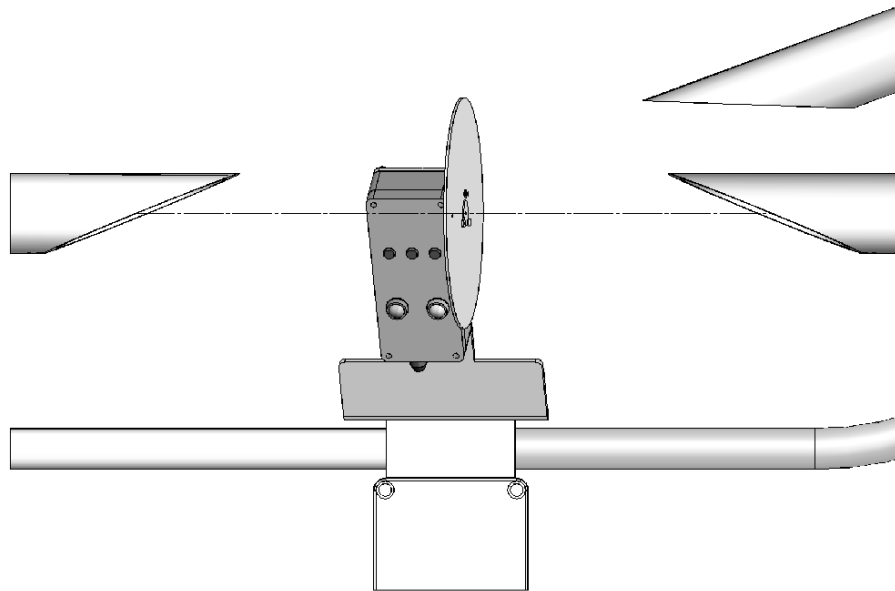

- Check that the velocity calibrator is located correctly and securely
- LED 'C' should now be flashing slowly and all other LEDs should be off
- Once you are ready, press 'START'
- The test is now automated and the disk should start rotating. LED 'C' will stay illuminated permanently until this stage of the test is complete
- Wait for the calibration disk to stop rotating. This test will take approximately two and a half minutes
- Upon successful completion of the test LED 'L' will be flashing slowly and LED 'C' will be turned off

Step 4: Position 2: Left

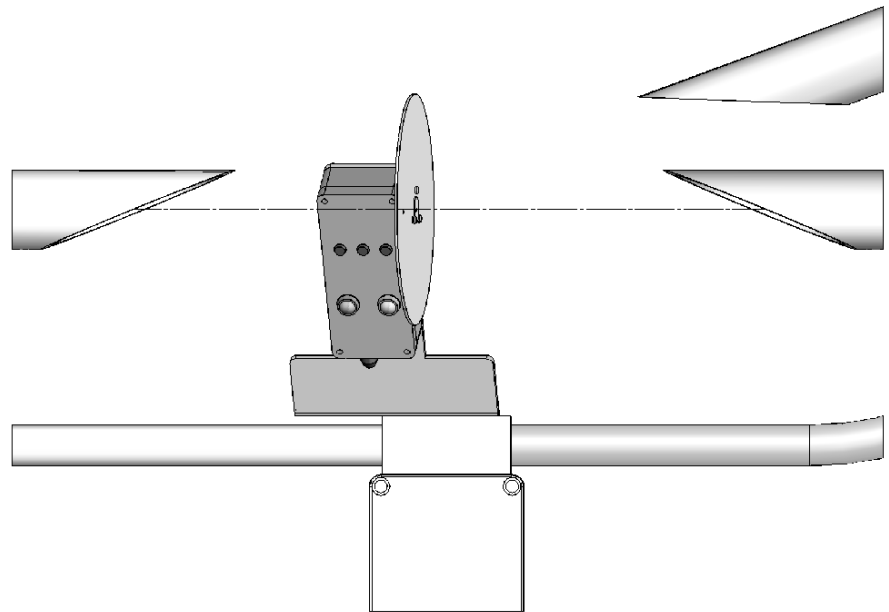

-
- Move the calibrator into the left hand position, by unscrewing the calibrator mounting screws slightly and sliding the calibrator fully to the left. Then retighten the screws once in position.
 - Visually check that the calibrator is located correctly and securely
 - LED 'L' should now be flashing slowly and all other LEDs should be off
 - Once you are ready, press 'START'
 - The test is now automated and the disk should start rotating. LED 'L' will stay illuminated permanently until this stage of the test is complete
 - Wait for the calibration disk to stop rotating. This test will take approximately two and a half minutes
 - Upon successful completion of the test LED 'R' will be flashing slowly and LED 'L' will be turned off

Step 5: Position 3: Right

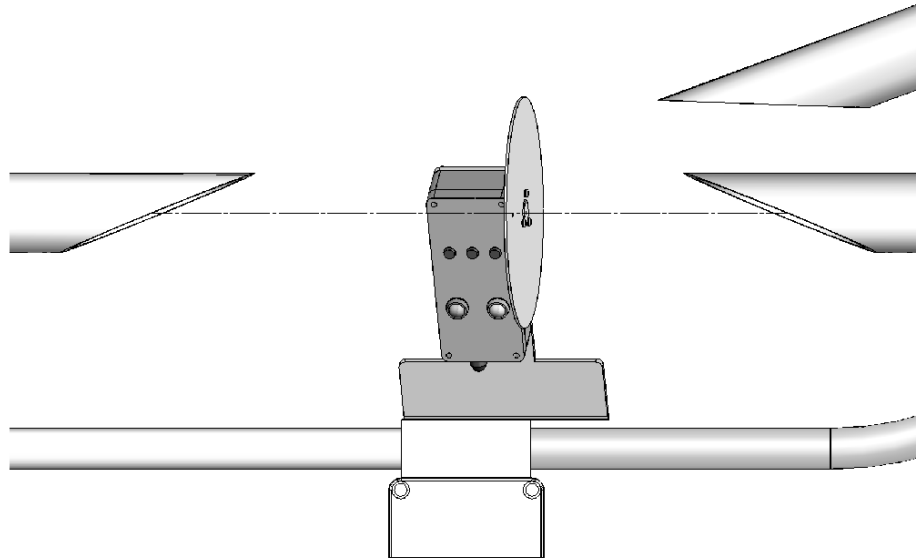

- Move the calibrator into the right hand position, by unscrewing the calibrator mounting screws slightly and sliding the calibrator fully to the right. Then retighten the screws once in position.
- Visually check that the calibrator is located correctly and securely
- LED 'R' should now be flashing slowly and all other LEDs should be off
- Once you are ready, press 'START'
- The test is now automated and the disk should start rotating. LED 'R' will stay illuminated permanently until this stage of the test is complete
- Wait for the calibration disk to stop rotating. This test will take approximately two and a half minutes

Final calibration results

The calibration verification has now been completed. All three of the LEDs should now all be permanently illuminated indicating that the PWS100 is still within its calibration limits.

If all three LEDs are flashing then this indicates that the calibration was found to be outside desired levels and further action needs to be taken.

If any of the calibration checks have failed (All three light flashing after test) then the tests should re-run after ensuring that the disk is clean and the area between the heads is clear of any obstructions. This should remove any chance that the calibrator or another external factor was the cause.

If the PWC100 still indicates a problem please contact Campbell Scientific for further advice.

Step 6: Final stage

- Remember to reinstall the plastic blanking screws back into the PWS100 before leaving the site.
- If a CS215 or other piece of equipment was unplugged in order to perform the tests then ensure it is reconnected.
- Remember to check that the blanking plug has not been left in the PWS
- Place all calibration equipment carefully back into its correct box being careful not to scratch the visibility disk.

Final calibration result table

Result/ LED Status	LED L	LED C	LED R	Description
Test passed	ON	ON	ON	If all tests have passed, all the LEDs will be illuminated at the same time
Calibration required	Flash	Flash	Flash	Calibration values are suspect. Do not use the calibration values created from this test

Fault states during tests

If during the calibration cycle LED C and R start flashing together then this indicates that there has been an error either with the communications to the PWS100 or that the disk has stalled or is unable to attain the required speed for calibration.

State	LED L	LED C	LED R	Description
Disk stalled	-	Flash	Flash	PWS calibrator problem

Quick look LED status table

Test state	Ready/complete state			Running state		
	Left	Centre	Right	Left	Centre	Right
Visibility test	Flash		Flash	ON		ON
Visibility maximum range test	Flash	Flash		ON	ON	
Velocity test position 1 (Centre)		Flash			ON	
Velocity test position 2 (Left)	Flash			ON		
Velocity test position 3 (Right)			Flash			ON
Final result states						
Calibration passed	ON	ON	ON			
Calibration required	Flash	Flash	Flash			
Error conditions						
Fault occurrence during tests		Flash	Flash			

4. Cleaning guide

It is important to ensure that the visibility and velocity disks are clean prior to use. Finger prints and small quantities of dust should not impair performance significantly, but it is highly recommended that the disks are kept clean and care is taken to ensure the surfaces are not scratched, cracked or damaged. A cleaning agent that does not leave a residue such as isopropyl alcohol or a product specifically designed to clean optical equipment should be used along with a lint free cloth.

5. Calibrator safety guidelines

During the velocity tests the calibration disk will be rotated at a moderate speed.

It is recommended that the user visually checks the disk for any cracks or distortions on its surface. If the disk is cracked or distorted in any way the tests should not be performed as this may cause an incorrect result or even damage to the calibration unit. Campbell Scientific should be contacted for advice about any damage that may have occurred to the disk.

When performing the tests the operator should ensure he is not within two metres of the calibrator. This will ensure the operator does not interfere with the results by causing reflections and that they are out of range of the rotating disk.

It is also recommended that the operator stands behind the laser hood whilst the PWS is active.

6. Electrical parameters

6.1 PWC-100 voltages and currents

	Nominal	Max	Notes
General details			
Standby current	29mA	30mA	No tests running
Operating current	125mA	150mA	Disk rotating at test speed
Spin up current	500mA	700mA	Disk spinning up to speed
+ Volts	+12V	+28V	Main supply voltage

(The PWC100 will function correctly with a PWS100 operating within its supply voltage range).

6.2 Earth, 0V and transient protection

The user must ensure that the ground lug on the PWS is connected to the earth lug on the logger or another suitable termination point. The PWC100 is connected to this earth via the umbilical cable. This connection acts as the discharge path for electrical transients such as static and surge. Failure to correctly terminate this connection could lead to damage to the unit or faulty operation.

The PWC100 is protected against external electro-static discharges from user contact but not lightning related surges caused by nearby strikes.

Therefore do not leave the PWC100 connected to the PWS100 for prolonged periods in field conditions.

Appendix A. Assembly guidelines

A1. Assembly guidelines

The PWC100 visibility and velocity calibration disks can easily be removed for cleaning or repair if needed.

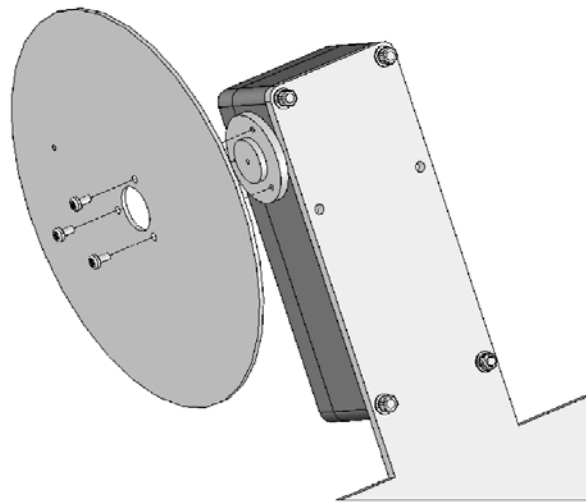

Fig. A1a Attaching the velocity disk

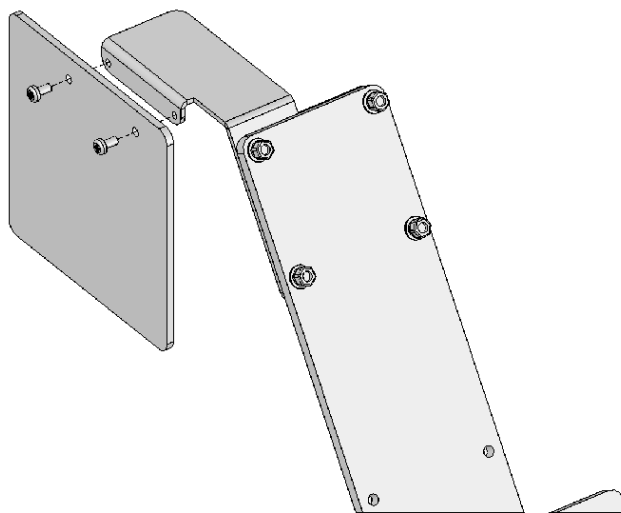

Fig. A1b Attaching the visibility disk

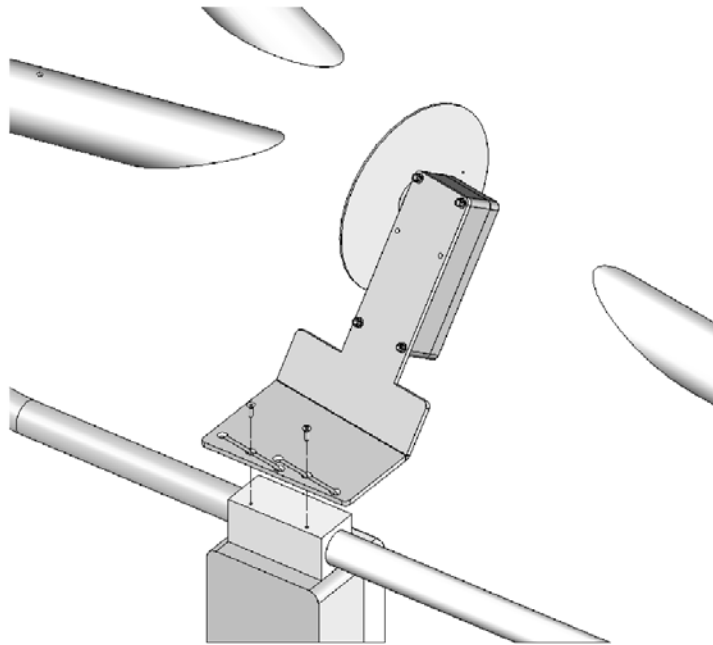
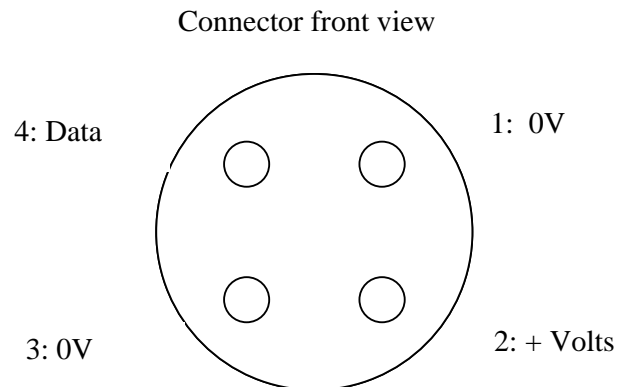

Fig. A2. Attachment of the velocity calibrator

A2. Connector pin outs



CAMPBELL SCIENTIFIC COMPANIES

Campbell Scientific, Inc. (CSI)

815 West 1800 North
Logan, Utah 84321
UNITED STATES

www.campbellsci.com • info@campbellsci.com

Campbell Scientific Africa Pty. Ltd. (CSAf)

PO Box 2450
Somerset West 7129
SOUTH AFRICA

www.csafrica.co.za • sales@csafrica.co.za

Campbell Scientific Australia Pty. Ltd. (CSA)

PO Box 444
Thuringowa Central
QLD 4812 AUSTRALIA

www.campbellsci.com.au • info@campbellsci.com.au

Campbell Scientific do Brazil Ltda. (CSB)

Rua Luisa Crapsi Orsi, 15 Butantã
CEP: 005543-000 São Paulo SP BRAZIL

www.campbellsci.com.br • suporte@campbellsci.com.br

Campbell Scientific Canada Corp. (CSC)

11564 - 149th Street NW
Edmonton, Alberta T5M 1W7
CANADA

www.campbellsci.ca • dataloggers@campbellsci.ca

Campbell Scientific Centro Caribe S.A. (CSCC)

300N Cementerio, Edificio Breller
Santo Domingo, Heredia 40305
COSTA RICA

www.campbellsci.cc • info@campbellsci.cc

Campbell Scientific Ltd. (CSL)

Campbell Park
80 Hathern Road
Shepshed, Loughborough LE12 9GX
UNITED KINGDOM

www.campbellsci.co.uk • sales@campbellsci.co.uk

Campbell Scientific Ltd. (France)

3 Avenue de la Division Leclerc
92160 ANTONY
FRANCE

www.campbellsci.fr • info@campbellsci.fr

Campbell Scientific Spain, S. L.

Avda. Pompeu Fabra 7-9
Local 1 - 08024 BARCELONA
SPAIN

www.campbellsci.es • info@campbellsci.es

Campbell Scientific Ltd. (Germany)

Fahrenheitstrasse13, D-28359 Bremen
GERMANY

www.campbellsci.de • info@campbellsci.de