

WHITE PAPER

The Benefits of Input Reversal and Excitation Reversal for Voltage Measurements



CAMPBELL SCIENTIFIC, INC.

815 W. 1800 N. • Logan, Utah 84321-1784 • (435) 753-2342 • FAX (435) 750-9540

The Benefits of Input Reversal and Excitation Reversal for Voltage Measurements

This application note discusses the theory behind using input reversal and excitation reversal in voltage measurements. Both techniques are standard measurement features in Campbell Scientific dataloggers.

Input Reversal

Input reversal is often used in differential measurements (Fig. 1) to reduce instrumentation amplifier (IA) offset and common-mode gain errors. The result is obtained from two separate differential measurements, Φ_1 and Φ_2 , where the polarity of the input signal with respect to the IA is reversed between the two. The polarity of the offset and common-mode gain errors are not reversed, however, and these errors cancel when Φ_2 is subtracted from Φ_1 .

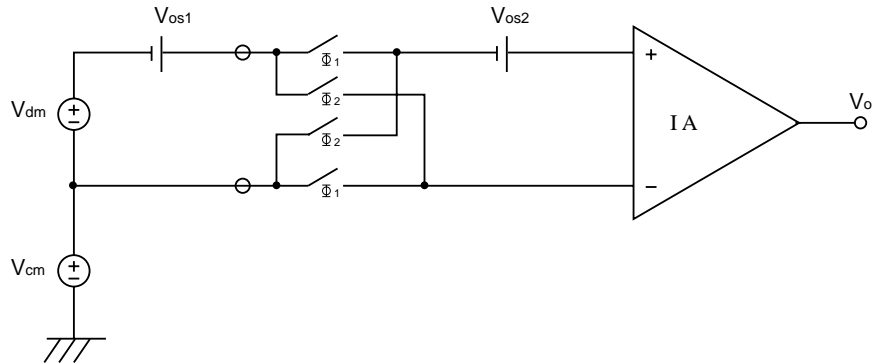

Figure 1. Reversed Differential Inputs.

Referring to Fig. 1, the result of the first measurement is

$$V_o(\Phi_1) = A_{dm}(V_{dm} + V_{os1} + V_{os2}) + A_{cm}V_{cm} , \quad (\text{Eq. 1})$$

where

V_{dm} = differential-mode signal

V_{cm} = common-mode signal

A_{dm} = differential-mode gain of IA

A_{cm} = common-mode gain of IA

V_{os1} = dc offset voltage error occurring before input reversal switches

V_{os2} = dc offset voltage error occurring after input reversal switches.

Ideally the common-mode gain A_{cm} is zero. For low-frequency signals this error is often smaller than the measurement resolution of the datalogger. Common-mode gain error is discussed in more detail later on.

The result of the second measurement made with opposite input polarity is

$$V_o(\Phi_2) = A_{dm}(-V_{dm} - V_{os1} + V_{os2}) + A_{cm}V_{cm} . \quad (\text{Eq. 2})$$

Subtracting Eq. 2 from Eq. 1 and dividing by two yields the final result,

$$\frac{1}{2}V_o(\Phi_1 - \Phi_2) = A_{dm}V_{dm} + A_{dm}V_{os1} . \quad (\text{Eq. 3})$$

Input reversal effectively removes the IA common-mode rejection errors, and the dc offset voltage errors occurring after the input reversal switches.

Excitation Reversal

What techniques exist for removing dc offset voltage errors occurring before the input reversal switches? For bridge measurements (Fig. 2), these errors can be removed by reversing the polarity of the bridge excitation voltage V_x .

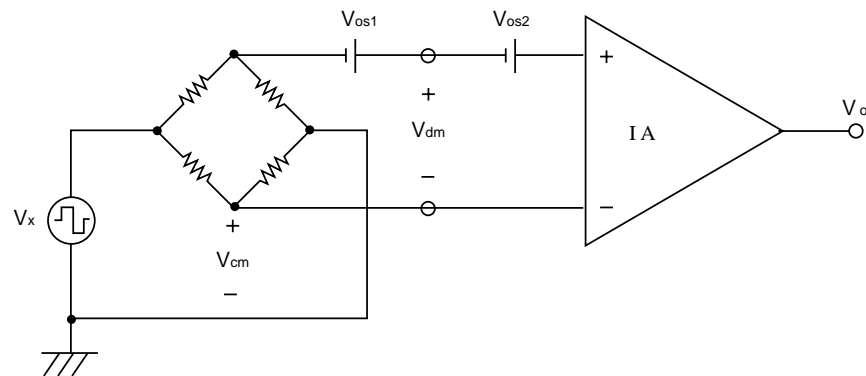

Figure 2. Excitation Reversal for Full-Bridge Measurement

Referring to Fig. 2, the result of the first measurement is

$$V_o(\Phi_1) = A_{dm}(V_{dm} + V_{os1} + V_{os2}) + A_{cm}V_{cm} . \quad (\text{Eq. 4})$$

Using an excitation voltage of equal magnitude but opposite polarity, the result of the second measurement is

$$V_o(\Phi_2) = A_{dm}(-V_{dm} + V_{os1} + V_{os2}) + A_{cm}(-V_{cm}) . \quad (\text{Eq. 5})$$

Subtracting Eq. 5 from Eq. 4 and dividing by 2 yields the final result,

$$\frac{1}{2}V_o(\Phi_1 - \Phi_2) = A_{dm}V_{dm} + A_{cm}V_{cm} . \quad (\text{Eq. 6})$$

Reversing the excitation polarity eliminates the effects of external and internal dc offset voltage errors, although the IA common-mode errors, eliminated with input reversal, remain.

For dc signals, A_{cm} is typically on the order of 0.00001 (-100 dB). A 16-bit analog-to-digital conversion results in a measurement resolution that is $1/65,536$ of full-scale or $20\log(2^{-16}) = -96$ dB with respect to full-scale. Consequently, an A_{cm} of -100 dB will result in negligible common-mode errors for a 16-bit measurement resolution. The CR7, CR5000, CR9000 dataloggers offer 16-bit measurement resolution, the CR23X offers 15-bit resolution, and the CR510 and CR10X offer 13-bit resolution.

The resulting common-mode gain error illustrated in Eq. 6 may not always be negligible. For example, the CR5000 has a worst-case dc A_{cm} of -80 dB (0.0001) without input reversal (typical $A_{cm} = -96$ dB). Assuming $V_{cm} = 2.5$ V, which is the case for a 5 V bridge excitation, the worst-case error is $A_{cm}V_{cm} = 250$ μ V at the IA output. To compare this 250 μ V error with an input signal level, it must be divided by the differential-mode gain A_{dm} of the IA. For the CR5000, $A_{dm} = 50$ on the ± 20 mV input range. The resulting input referred error is 5.0 μ V on the ± 20 mV input range.

Combining Input and Excitation Reversal

Input and excitation reversal can be combined to completely eliminate dc common-mode rejection errors along with dc offset voltage errors. Four measurements are required. The four-measurement method also offers further noise reduction because of additional averaging. The sequence used is excitation reversal (two measurements) at a given input polarity followed by excitation reversal (two measurements) at the opposite input polarity.

All Campbell Scientific dataloggers incorporate input and excitation reversal, where appropriate. The CR5000 and CR9000 dataloggers offer users a choice of using input reversal, excitation reversal, or both in the measurement sequence.