

# INSTRUCTION MANUAL



## **CS705 Snowfall Adapter**

Revision: 1/17



Copyright © 1997-2017  
Campbell Scientific, Inc.



# Guarantee

---

This equipment is guaranteed against defects in materials and workmanship. We will repair or replace products which prove to be defective during the guarantee period as detailed on your invoice, provided they are returned to us prepaid. The guarantee will not apply to:

- Equipment which has been modified or altered in any way without the written permission of Campbell Scientific
- Batteries
- Any product which has been subjected to misuse, neglect, acts of God or damage in transit.

Campbell Scientific will return guaranteed equipment by surface carrier prepaid. Campbell Scientific will not reimburse the claimant for costs incurred in removing and/or reinstalling equipment. This guarantee and the Company's obligation thereunder is in lieu of all other guarantees, expressed or implied, including those of suitability and fitness for a particular purpose. Campbell Scientific is not liable for consequential damage.

Please inform us before returning equipment and obtain a Repair Reference Number whether the repair is under guarantee or not. Please state the faults as clearly as possible, and if the product is out of the guarantee period it should be accompanied by a purchase order. Quotations for repairs can be given on request. It is the policy of Campbell Scientific to protect the health of its employees and provide a safe working environment, in support of this policy a "Declaration of Hazardous Material and Decontamination" form will be issued for completion.

When returning equipment, the Repair Reference Number must be clearly marked on the outside of the package. Complete the "Declaration of Hazardous Material and Decontamination" form and ensure a completed copy is returned with your goods. Please note your Repair may not be processed if you do not include a copy of this form and Campbell Scientific Ltd reserves the right to return goods at the customers' expense.

Note that goods sent air freight are subject to Customs clearance fees which Campbell Scientific will charge to customers. In many cases, these charges are greater than the cost of the repair.



Campbell Scientific Ltd,  
80 Hathern Road,  
Shepshed, Loughborough, LE12 9GX, UK  
Tel: +44 (0) 1509 601141  
Fax: +44 (0) 1509 601091  
Email: [support@campbellsci.co.uk](mailto:support@campbellsci.co.uk)  
[www.campbellsci.co.uk](http://www.campbellsci.co.uk)



# PLEASE READ FIRST

---

## About this manual

Please note that this manual was originally produced by Campbell Scientific Inc. primarily for the North American market. Some spellings, weights and measures may reflect this origin.

Some useful conversion factors:

|  |   |
|--|---|
| <b>Area:</b> 1 in <sup>2</sup> (square inch) = 645 mm <sup>2</sup>                                       | <b>Mass:</b> 1 oz. (ounce) = 28.35 g<br>1 lb (pound weight) = 0.454 kg                          |
| <b>Length:</b> 1 in. (inch) = 25.4 mm<br>1 ft (foot) = 304.8 mm<br>1 yard = 0.914 m<br>1 mile = 1.609 km | <b>Pressure:</b> 1 psi (lb/in <sup>2</sup> ) = 68.95 mb   |
|  | <b>Volume:</b> 1 UK pint = 568.3 ml<br>1 UK gallon = 4.546 litres<br>1 US gallon = 3.785 litres |

In addition, while most of the information in the manual is correct for all countries, certain information is specific to the North American market and so may not be applicable to European users.

Differences include the U.S standard external power supply details where some information (for example the AC transformer input voltage) will not be applicable for British/European use. *Please note, however, that when a power supply adapter is ordered it will be suitable for use in your country.*

Reference to some radio transmitters, digital cell phones and aerials may also not be applicable according to your locality.

Some brackets, shields and enclosure options, including wiring, are not sold as standard items in the European market; in some cases alternatives are offered. Details of the alternatives will be covered in separate manuals.

Part numbers prefixed with a “#” symbol are special order parts for use with non-EU variants or for special installations. Please quote the full part number with the # when ordering.

## Recycling information



At the end of this product's life it should not be put in commercial or domestic refuse but sent for recycling. Any batteries contained within the product or used during the products life should be removed from the product and also be sent to an appropriate recycling facility.

Campbell Scientific Ltd can advise on the recycling of the equipment and in some cases arrange collection and the correct disposal of it, although charges may apply for some items or territories.

For further advice or support, please contact Campbell Scientific Ltd, or your local agent.



Campbell Scientific Ltd, 80 Hathern Road, Shepshed, Loughborough, LE12 9GX, UK  
Tel: +44 (0) 1509 601141 Fax: +44 (0) 1509 601091  
Email: [support@campbellsci.co.uk](mailto:support@campbellsci.co.uk)  
[www.campbellsci.co.uk](http://www.campbellsci.co.uk)



# Precautions

---

DANGER — MANY HAZARDS ARE ASSOCIATED WITH INSTALLING, USING, MAINTAINING, AND WORKING ON OR AROUND **TRIPODS, TOWERS, AND ANY ATTACHMENTS TO TRIPODS AND TOWERS SUCH AS SENSORS, CROSSARMS, ENCLOSURES, ANTENNAS, ETC.** FAILURE TO PROPERLY AND COMPLETELY ASSEMBLE, INSTALL, OPERATE, USE, AND MAINTAIN TRIPODS, TOWERS, AND ATTACHMENTS, AND FAILURE TO HEED WARNINGS, INCREASES THE RISK OF DEATH, ACCIDENT, SERIOUS INJURY, PROPERTY DAMAGE, AND PRODUCT FAILURE. TAKE ALL REASONABLE PRECAUTIONS TO AVOID THESE HAZARDS. CHECK WITH YOUR ORGANIZATION'S SAFETY COORDINATOR (OR POLICY) FOR PROCEDURES AND REQUIRED PROTECTIVE EQUIPMENT PRIOR TO PERFORMING ANY WORK.

Use tripods, towers, and attachments to tripods and towers only for purposes for which they are designed. Do not exceed design limits. Be familiar and comply with all instructions provided in product manuals. Manuals are available at [www.campbellsci.eu](http://www.campbellsci.eu) or by telephoning +44(0) 1509 828 888 (UK). You are responsible for conformance with governing codes and regulations, including safety regulations, and the integrity and location of structures or land to which towers, tripods, and any attachments are attached. Installation sites should be evaluated and approved by a qualified engineer. If questions or concerns arise regarding installation, use, or maintenance of tripods, towers, attachments, or electrical connections, consult with a licensed and qualified engineer or electrician.

## General

- Prior to performing site or installation work, obtain required approvals and permits. Comply with all governing structure-height regulations, such as those of the FAA in the USA.
- Use only qualified personnel for installation, use, and maintenance of tripods and towers, and any attachments to tripods and towers. The use of licensed and qualified contractors is highly recommended.
- Read all applicable instructions carefully and understand procedures thoroughly before beginning work.
- Wear a **hardhat** and **eye protection**, and take **other appropriate safety precautions** while working on or around tripods and towers.
- **Do not climb** tripods or towers at any time, and prohibit climbing by other persons. Take reasonable precautions to secure tripod and tower sites from trespassers.
- Use only manufacturer recommended parts, materials, and tools.

## Utility and Electrical

- **You can be killed** or sustain serious bodily injury if the tripod, tower, or attachments you are installing, constructing, using, or maintaining, or a tool, stake, or anchor, come in **contact with overhead or underground utility lines.**
- Maintain a distance of at least one-and-one-half times structure height, or 20 feet, or the distance required by applicable law, **whichever is greater**, between overhead utility lines and the structure (tripod, tower, attachments, or tools).
- Prior to performing site or installation work, inform all utility companies and have all underground utilities marked.
- Comply with all electrical codes. Electrical equipment and related grounding devices should be installed by a licensed and qualified electrician.

## Elevated Work and Weather

- Exercise extreme caution when performing elevated work.
- Use appropriate equipment and safety practices.
- During installation and maintenance, keep tower and tripod sites clear of un-trained or non-essential personnel. Take precautions to prevent elevated tools and objects from dropping.
- Do not perform any work in inclement weather, including wind, rain, snow, lightning, etc.

## Maintenance

- Periodically (at least yearly) check for wear and damage, including corrosion, stress cracks, frayed cables, loose cable clamps, cable tightness, etc. and take necessary corrective actions.
- Periodically (at least yearly) check electrical ground connections.

WHILE EVERY ATTEMPT IS MADE TO EMBODY THE HIGHEST DEGREE OF SAFETY IN ALL CAMPBELL SCIENTIFIC PRODUCTS, THE CUSTOMER ASSUMES ALL RISK FROM ANY INJURY RESULTING FROM IMPROPER INSTALLATION, USE, OR MAINTENANCE OF TRIPODS, TOWERS, OR ATTACHMENTS TO TRIPODS AND TOWERS SUCH AS SENSORS, CROSSARMS, ENCLOSURES, ANTENNAS, ETC.





# Table of Contents

---

*PDF viewers: These page numbers refer to the printed version of this document. Use the PDF reader bookmarks tab for links to specific sections.*

|   |            |
|---|------------|
| <b>1. Introduction .....</b>                                  | <b>1</b>   |
| <b>2. Precautions .....</b>                                   | <b>1</b>   |
| <b>3. Initial Inspection.....</b>                             | <b>1</b>   |
| 3.1 Ships With.....   | 2          |
| <b>4. Overview .....</b>                                      | <b>2</b>   |
| 4.1 Antifreeze.....   | 3          |
| 4.1.1 Standard Car or RV Antifreeze is NOT Recommended .....  | 3          |
| 4.2 Tipping Bucket Compatibility.....                         | 3          |
| <b>5. Specifications.....</b>                                 | <b>3</b>   |
| <b>6. Installation .....</b>                                  | <b>4</b>   |
| 6.1 Siting.....   | 4          |
| 6.2 Mounting Pole.....  | 4          |
| 6.3 CM270 Installation .....                                  | 7          |
| 6.4 CS705-to-Tipping Bucket Installation Procedure .....      | 11         |
| 6.5 Datalogger Programming.....                               | 13         |
| <b>7. Maintenance .....</b>                                   | <b>13</b>  |
| <b>8. References.....</b>                                     | <b>14</b>  |
| <b>Appendix</b>   |            |
| <b>A. MSDS for Campbell Scientific CS705 Antifreeze .....</b> | <b>A-1</b> |

## **Figures**

|   |    |
|---|----|
| 6-1. Proper gauge siting.....   | 4  |
| 6-2. CM310 56-inch pole embedded in a concrete foundation.....          | 5  |
| 6-3. Pedestal kit options .....   | 6  |
| 6-4. Exploded view of the CM270 Mounting Bracket Kit .....              | 8  |
| 6-5. Two views of an assembled CM270 .....                              | 8  |
| 6-6. Mounting CM270 to the rain gauge .....                             | 9  |
| 6-7. Exploded view of CM270 mounting hardware (TE525WS not shown) ..... | 10 |
| 6-8. CS705 mounted to pole using the CM270 Mounting Kit.....            | 11 |
| 6-9. CS705 exploded view .....  | 12 |
| 7-1. Mix ratio versus precipitation received.....                       | 13 |



# CS705 Snowfall Adapter

---

## 1. Introduction

The CS705 Snowfall Adapter converts a TE525WS Texas Electronics Rain Gauge to a rain and snow gauge. It consists of an antifreeze reservoir, overflow tube, and catch tube. Snow captured in the catch tube dissolves into the antifreeze raising the overall level. The mixture flows through the overflow tube into the tipping bucket where it is measured. A slot in the top of the overflow tube prevents the tube from developing a siphon.

Before installing the CS705, please study

- Section 2, *Precautions* (p. 1)
- Section 3, *Initial Inspection* (p. 1)

## 2. Precautions

- READ AND UNDERSTAND the *Safety* section at the front of this manual.
- The CS705 possesses inherent delays and is not suitable for real-time precipitation measurements (see Section 4, *Overview* (p. 2)).
- Since regular maintenance is required, choose a site that is easily accessible throughout the winter.
- Wear safety glasses and rubber or neoprene gloves while handling and pouring antifreeze.
- Campbell Scientific strongly recommends using antifreeze consisting of a 1:1 mixture of propylene glycol and ethanol (PGE). Appendix A, *MSDS for Campbell Scientific CS705 Antifreeze* (p. A-1), provides MSDS information for the PGE antifreeze offered by Campbell Scientific.
- Avoid using the antifreeze commonly used in cars or RVs. This antifreeze, which consists of propylene glycol or ethylene glycol, increases the likelihood of ice bridging (see Section 4.1, *Antifreeze* (p. 3)).
- The antifreeze/snowfall mixture needs to be captured from the tipping bucket gauge and properly disposed of in accordance with local, state, and federal regulations.
- The CS705 should be removed and cleaned in the summer, and reinstalled before the winter season.

## 3. Initial Inspection

- Upon receipt of the CS705, inspect the packaging and contents for damage. File damage claims with the shipping company.
- Immediately check package contents against the shipping documentation (see Section 3.1, *Ships With* (p. 2)). Contact Campbell Scientific about any discrepancies.

### 3.1 Ships With

The CS705 ships with:

- (1) CM270 Rain Gauge Mounting Kit
- (1) Stainless-Steel Band Clamp (pn #20606)
- (1) Stainless-Steel Band Clamp (pn #20605)
- (1) Drain Funnel (pn #14087)

Refer to FIGURE 6-8 for information on positioning the various mounting hardware.

The CM270 mounting kit includes the following:

- (1) Storage mount (pn #20636)
- (3) Screws (pn #9580, 1/4-20)
- (2) Flat washers (pn #4365)
- (2) Lock washers (pn #4366)
- (2) Carriage bolts (pn #31922)
- (2) Wingnuts (pn #27552)
- (1) Mast clamp (pn #27550)
- (3) Grommets (pn #30838)
- (1) Bottom plate (pn #31917)
- (1) V-shaped plate (pn #31413)
- (1) S-shaped plate (pn #31414)
- (2) Springs (pn #20628)
- (1) Spacer (pn #32009)
- (3) Screws (pn #30978)

## 4. Overview

The CS705 is manufactured by Campbell Scientific and is based on the paper “Measuring Winter Precipitation with an Antifreeze-Based Tipping Bucket System” presented at the 1996 Western Snow Conference (McCaughey and Farnes, 1996). The design possesses inherent delays and is not suitable for real time precipitation measurements. Three design factors contribute to measurement delays:

- air / antifreeze mixture temperature
- surface tension in the overflow tube
- precipitation form

All precipitation falling into the catch tube eventually flows through the overflow tube and is measured by the tipping bucket gauge. A delay of minutes is expected for liquid precipitation so long as a minimum volume of water ( $\approx 0.03$  inches) is reached. A delay of several hours (up to tens) is expected for snow. Lightest density snow at very cold temperatures has the longest delay.

The CS705 converts the TE525WS Texas Electronic Rain Gauge, into a year-round precipitation gauge. The CS705 is intended for use only during winter. Like any sensor, optimum performance is obtained by regular site visits. Any antifreeze-based precipitation gauge orifice is susceptible to capping or snow bridging.

---

**NOTE** The CS705 is coated with a smooth black coating to minimize surface adhesion and maximize solar loading, but snow bridging may still not occur.

---

## 4.1 Antifreeze

Campbell Scientific recommends a 1:1 mixture of propylene glycol and ethanol (PGE). PGE is available from Campbell Scientific in a package of four, one-gallon containers. Antifreeze can only be shipped in multiples of four gallons via UPS Ground and cannot be shipped outside of the continental United States.

### 4.1.1 Standard Car or RV Antifreeze is NOT Recommended

Standard car or RV antifreeze consists of propylene glycol or ethylene glycol, which have a specific gravity >1. This allows a layer of water to sit on top of the antifreeze that may freeze and form an ice cap that prevents snowfall from being dissolved into the solution. Mixing the antifreeze with ethanol solves the specific gravity issue and prevents the ice cap. PGE is also more environmentally friendly.

## 4.2 Tipping Bucket Compatibility

The CS705 is equipped with a specially sized cylinder that allows it to nest within the 8-inch orifice of the TE525WS Texas Electronic Rain Gauge. The CS705 cannot be directly used with TE525, TE525MM, CS700, or TB4 rain gauges. However, the TE525 and TE525MM gauges can be converted to a TE525WS at Campbell Scientific. Refer to the [Assistance](#) section at the front of this manual for the steps required to return equipment to Campbell Scientific.

# 5. Specifications

|   |  |
|---|--|
| <b>Construction:</b>                      | Black powder coated aluminium  |
| <b>Capacity:</b>                          | 20.32 cm (8 in) of liquid @ -20°C operating temperature (assuming 1:0 starting ratio of anti-freeze to water). |
| <b>Recommended Antifreeze:</b>            | 1:1 mixture of propylene glycol and ethanol (PGE)  |
| <b>Antifreeze Capacity:</b>               | ≈9.5 L (2.5 gallons)   |
| <b>Catch Tube Height:</b>                 | 25.4 cm (10 in)  |
| <b>Catch Tube Orifice:</b>                | 21 cm (8.25 in) diameter   |
| <b>Antifreeze Reservoir Height:</b>       | 36 cm (14 in)  |
| <b>Antifreeze Reservoir Diameter:</b>     | 21 cm (8.25 in)  |
| <b>Total Weight (CS705 + Antifreeze):</b> | ≈9 kg (20 lb)  |

## 6. Installation

### 6.1 Siting

Choose a site that is easily accessible throughout the winter.

The CS705 Snowfall Adapter and associated rain gauge should be mounted in a relatively level spot that is representative of the surrounding area. The lip of the funnel needs to be horizontal and 76 cm (30 in) above the ground or higher to prevent burial by snow. The ground cover around the gauge should be natural vegetation or gravel. Avoid mounting the gauge over concrete or paved surfaces.

The under catch of winter precipitation by antifreeze-based gauges is directly related to wind speed. Errors due to wind can be minimized by properly siting the gauge. The preferred gauge site is in a natural well protected location. To ensure proper catch, an angle of  $30^\circ$  to  $45^\circ$  from a vertical line drawn through the center of the gauge orifice to the surrounding obstructions should be maintained. FIGURE 6-1 illustrates the proper siting of a gauge.

Gauges sited improperly and subjected to high winds will under catch winter precipitation generating erroneous data. An improperly sited gauge subjected to high winds can be damaged by the wind.

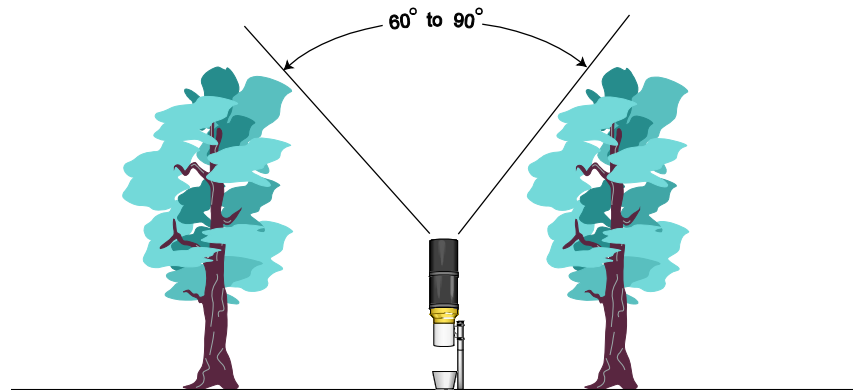

FIGURE 6-1. Proper gauge siting

### 6.2 Mounting Pole

A user-supplied mounting pole or Campbell Scientific CM300-series stainless-steel mounting pole can be used to mount the CS705 away from the tripod or tower.

CM300-series poles can be embedded directly into a concrete foundation (FIGURE 6-2) or used with a pedestal kit. Campbell Scientific offers a j-bolt pedestal kit, a short-leg (23 in) pedestal kit, and a long-leg (39 in) pedestal kit (see FIGURE 6-3).

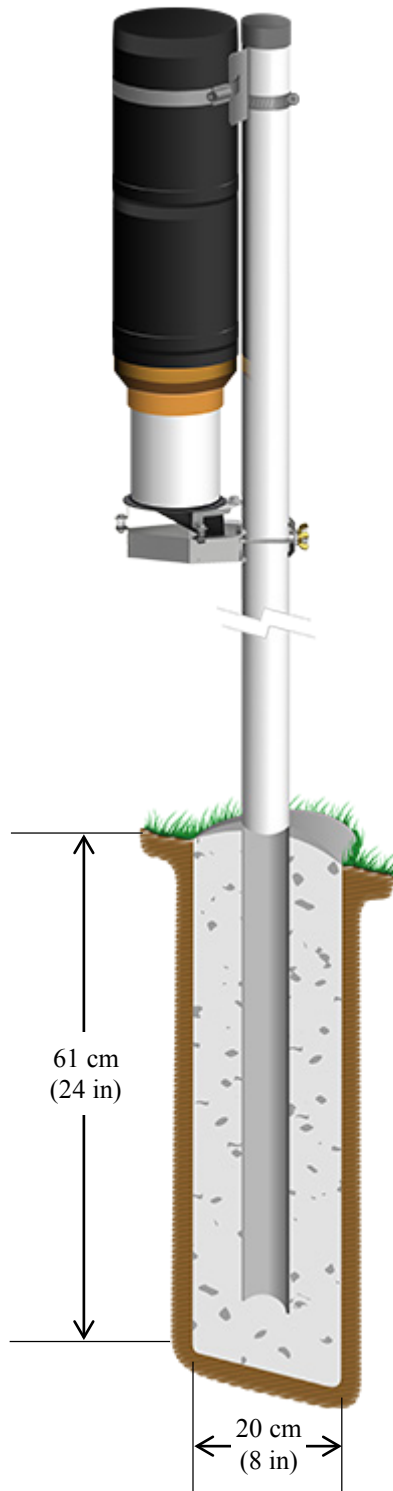

FIGURE 6-2. CM310 56-inch pole embedded in a concrete foundation

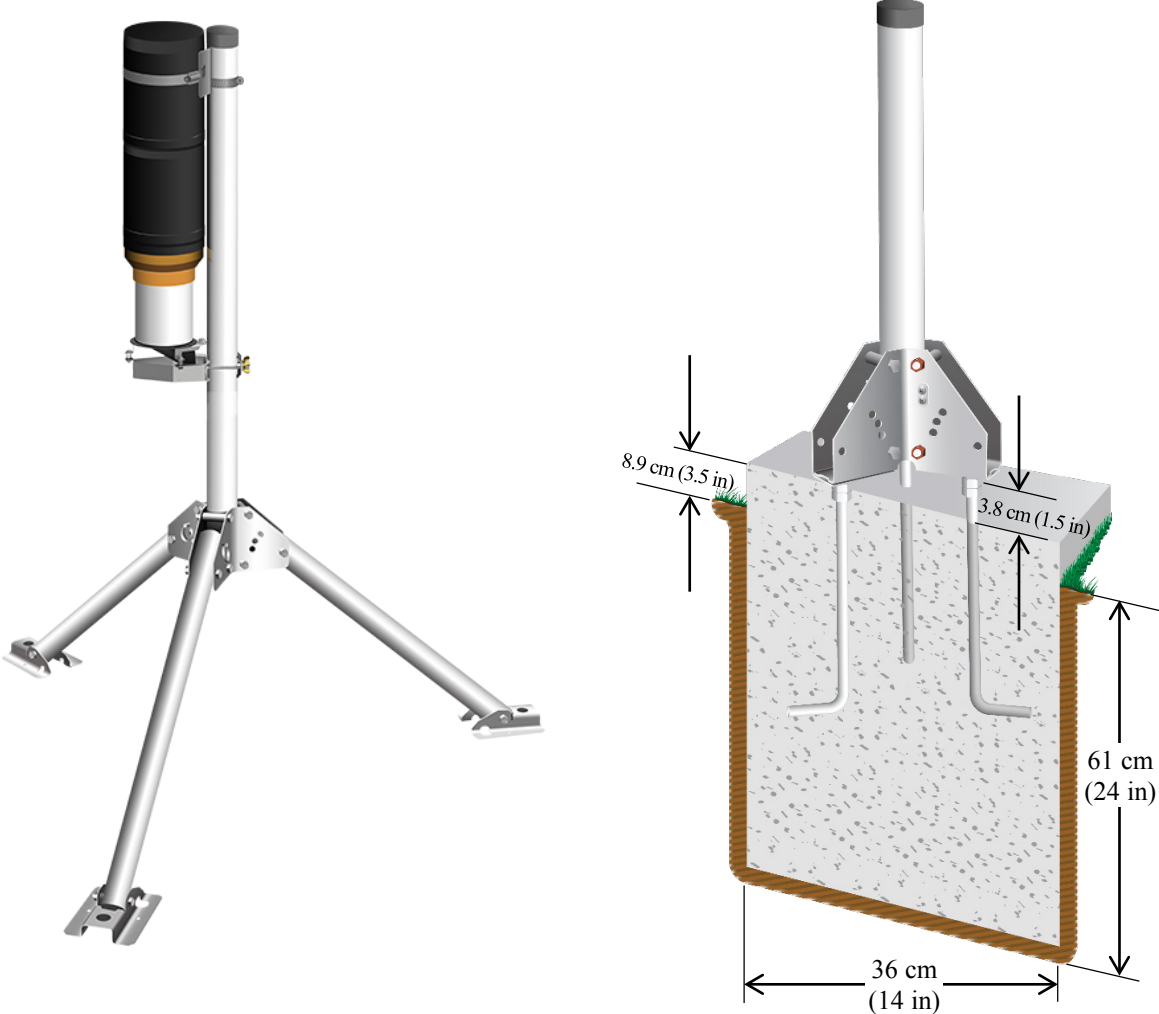

FIGURE 6-3. Pedestal kit options



## 6.3 CM270 Installation

Tools needed:

- Open end wrench, 7/16 inch open-ended wrench, or 7/16 inch socket wrench.
- Long #2 Phillips Screwdriver

Remove manufacturer's mounting hardware:

1. Remove the three feet mounted on the bottom of the rain gauge.
2. Remove the side bracket, but keep the screws.
3. Place the side bracket screws into the rain gauge and tighten. This keeps debris out of the threaded holes.

Do the following to assemble the mounting bracket. FIGURE 6-4 and FIGURE 6-5 show the bracket components and the proper assembly.

1. Remove the components from the shipping bag. To assemble the bracket, you will need the bottom plate, V-shaped plate, S-shaped plate, three bolts, two levelling springs, and cylindrical spacer. The bottom plate should come with three black nylon grommets mounted into it, and the pole mounting hardware attached to it.
2. Place the levelling springs over the bottom plate's side grommets.
3. Place the V-shaped plate onto the bottom plate. The V-shaped plate's legs should be on the levelling springs and the bubble level should be next to the pole-mounting hardware.
4. Use two bolts to secure the V-plate legs to the bottom plate (with the springs sandwiched between the two plates). Initially finger tighten the bolts and then use a wrench to further tighten them.

---

### CAUTION

Do not compress the springs at this time.

---

5. Place the cylindrical spacer on the bottom plate's front grommet.
6. Place the S-shaped plate on the spacer and use the bolt to secure it to the bottom plate. Initially finger tighten the bolt and then use a wrench to further tighten. Leave it a bit loose.

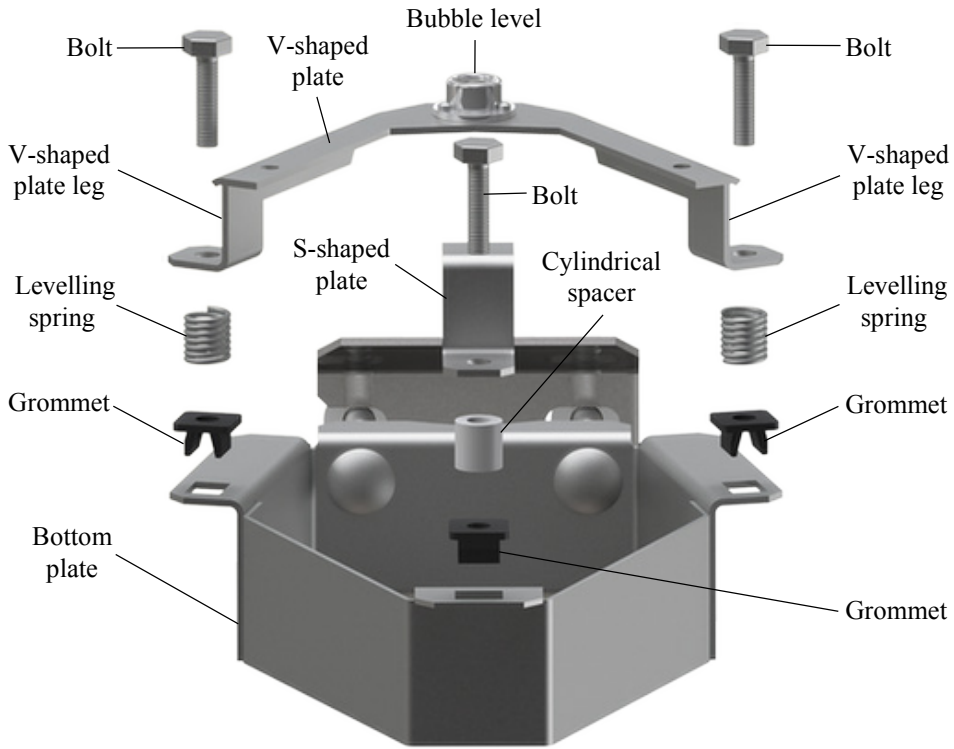

FIGURE 6-4. Exploded view of the CM270 Mounting Bracket Kit

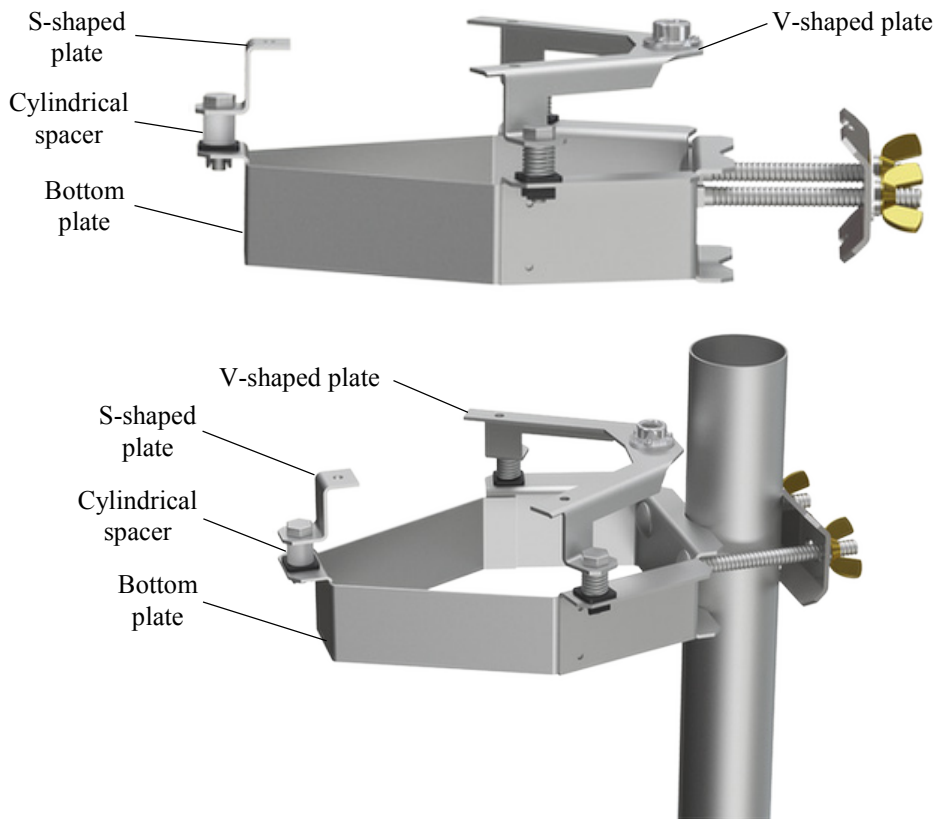

FIGURE 6-5. Two views of an assembled CM270

Do the following to mount the tipping bucket rain gauge to the CM270 bracket (FIGURE 6-6):

**NOTE**

Follow this procedure to ensure that the tipping bucket is mounted correctly. The adjustment screws for the tipping mechanism will not be accessible if it is mounted incorrectly.

1. Turn the rain gauge upside down and set it on a hard surface such as a table top.
2. Place the drain funnel on the bottom of the bucket. Line up the small holes on the drain funnel with the three holes used for the mounting feet. The larger holes on the drain funnel should fit over the round bolt heads.
3. Place the mounting bracket on the funnel. Line up the three holes in the mounting bracket with the three small holes on the funnel. When positioned correctly, the tipping bucket's cable will be near the bubble level and pole mounting hardware.
4. Use the three self-tapping screws and a long Phillips screwdriver to securely fasten the mounting bracket to the funnel and tipping bucket.
5. Flip the assembly over and tighten the bolt that uses the cylindrical spacer. The bolts securing the levelling springs need to remain loose to allow levelling when the bracket is mounted to the pole or mast.



FIGURE 6-6. Mounting CM270 to the rain gauge

Attach the mounting bracket/tipping bucket assembly to the mounting pipe or mast:

1. Install and level the mounting pipe or mast.
2. Loosen the mounting bracket's wingnuts and slide the assembly over the pipe. If necessary, the pole mounting hardware can be removed to get the bolts around the pipe. If this is necessary, to reassemble, put the mast clamp on first followed by the flat washer, lock washer, and wingnut. See FIGURE 6-7.
3. Tighten the assembly onto the pipe, while ensuring that nothing is blocking the top of the rain gauge.
4. Adjust the two bolts on the levelling springs until the bubble in the level is inside the bullseye.

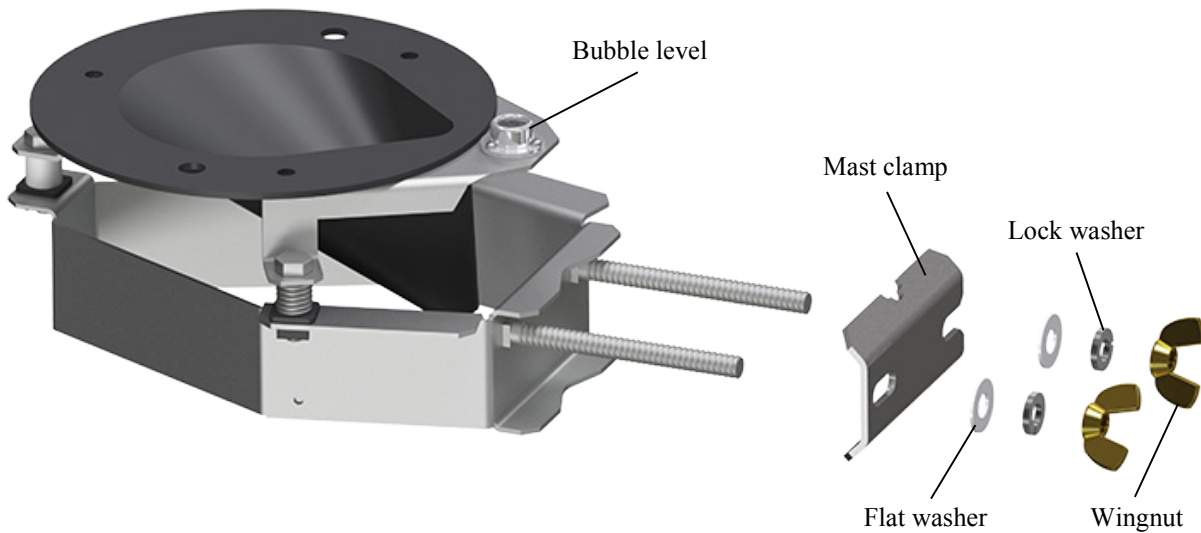

FIGURE 6-7. Exploded view of CM270 mounting hardware (TE525WS not shown)

## 6.4 CS705-to-Tipping Bucket Installation Procedure

Equipment required:

- User-supplied 0.5-inch (inner diameter) vinyl or Tygon tubing
- Pail
- TE525WS Texas Electronics Rain Gauge
- CS705 Snowfall Adapter
- PGE antifreeze
- Band Clamp (pn #20605)
- Band Clamp (pn #20606)
- Storage Mount (pn #20636)

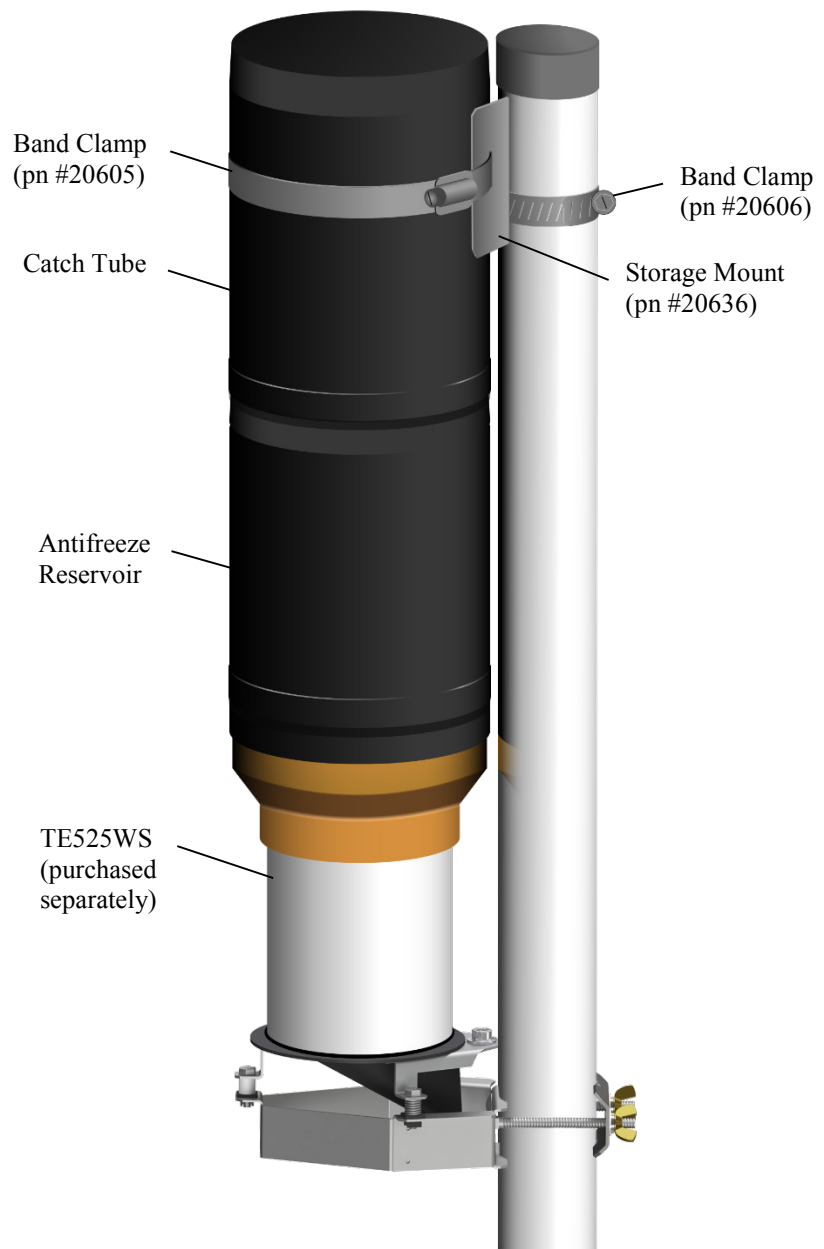

FIGURE 6-8. CS705 mounted to pole using the CM270 Mounting Kit

1. Take one of the black bands supplied with the CS705 and stretch over the TE525WS funnel (see FIGURE 6-8 and FIGURE 6-9).

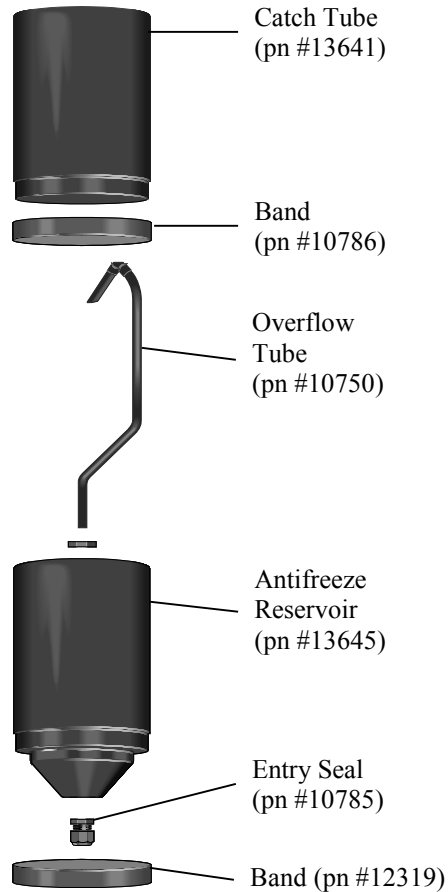

FIGURE 6-9. CS705 exploded view

2. Insert the CS705 antifreeze reservoir into the rain gauge funnel.

**CAUTION**

---

Wear safety glasses during handling and pouring of antifreeze.

---

3. Fill the reservoir with PGE antifreeze (pn #10869) until a small amount flows out the overflow tube. The reservoir holds  $\approx 2.5$  gallons.
4. Add  $\approx 8$  ounces of a low-freezing-point, environmentally-safe oil to the antifreeze reservoir. This oil prevents the antifreeze solution from evaporating. The oil should cover the entire liquid surface. Some unscented baby oils (lightweight mineral oil) work well.
5. Stretch the second black band over the lip of the antifreeze reservoir.
6. Insert the catch tube into the antifreeze reservoir.

7. Reposition the two black bands to cover the joints between the catch tube and the antifreeze reservoir and between the reservoir and the rain gauge funnel.
8. Fasten the catch tube of the CS705 to the mounting pole using the band clamps and storage mount (see FIGURE 6-8).
9. Place the pail below the rain gauge.
10. Connect one end of the tubing onto the funnel and place the other end of tubing in the pail.

## 6.5 Datalogger Programming

Refer to the manual supplied with the TE525WS Texas Electronics Rain Gauge. The manual is also available at [www.campbellsci.eu](http://www.campbellsci.eu).

## 7. Maintenance

The CS705 requires regular site visits. The number of required visits mainly depends on snowfall. Frequent or heavy snows require more site visits. During site visits, verify the slot in the top of the overflow tube is free from ice or debris and remove any debris from the catch orifice. If the slot in the overflow tube becomes plugged, the overflow tube may create a siphon and draw down the antifreeze level.

The PGE solution gets diluted as precipitation is captured and mixed. Initially, the CS705 is charged with a pure antifreeze mixture giving it a 1:0 antifreeze to water ratio. The ratio increases to 1:1 with the equivalent of six inches of liquid, 1:2 with eight inches, and 1:3 with nine inches. The 1:1 solution becomes slushy at a temperature of  $\approx -35^{\circ}\text{C}$ , the 1:2 solution becomes slushy at  $\approx -20^{\circ}\text{C}$ , and the 1:3 solution at  $\approx -10^{\circ}\text{C}$  (McGurk, 1992). Ratios greater than 1:3 are not recommended. Refer to FIGURE 7-1 to determine the amount of remaining antifreeze based on precipitation (water equivalent) recorded.

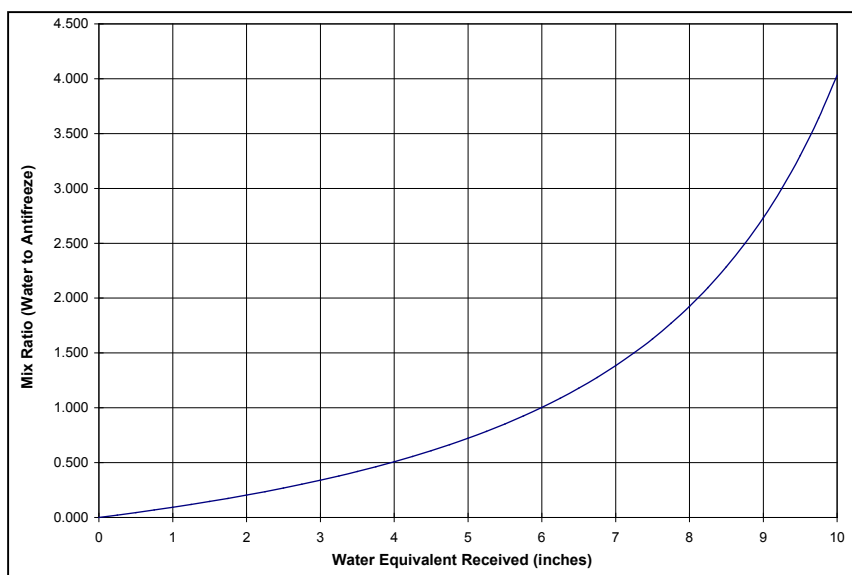

FIGURE 7-1. Mix ratio versus precipitation received

The PGE antifreeze used in the CS705 is biodegradable and generally considered to be environmentally safe. However, local laws, regulations, or policies may require the collection and safe disposal of all antifreeze used in the CS705. The #14087 funnel should be installed with the CM270 mounting kit and attached to user-supplied 0.5-inch (I.D.) vinyl or Tygon tubing that drains into a user-supplied pail. Please dispose of all spent antifreeze solution in accordance with local, state, and federal regulations.

The CS705 is recommended only for use during winter. It should be removed, cleaned, and carefully stored after the last snowfall, then reinstalled prior to the first snowfall of the coming winter.

## 8. References

- McCaughey, W. and Farnes, P.: 1996, "Measuring Winter Precipitation with an Antifreeze-Based Tipping Bucket System", *Proceedings 64<sup>th</sup> Western Snow Conference*, 130-136.
- McGurk, B.J.: 1992, "Propylene Glycol and Ethanol as a Replacement Antifreeze for Precipitation Gauges: Dilution, Disposal, and Safety", *Proceedings 60<sup>th</sup> Western Snow Conference*, 56-65.



# Appendix A. MSDS for Campbell Scientific CS705 Antifreeze

Interstate Chemical Co. Date Printed: 09-26-1997 Page 1  
MSDS for CAMPBELL SCIENTIFIC CS705 ANTIFREEZE 1899--

## 1 — Site Specific Information

Customer:

## 2 — Section I – General Information

MANUFACTURER'S NAME: Interstate Chemical Co.

EMERGENCY TELEPHONE NUMBER: (412) 981-3771

CHEMTREC EMERGENCY TELEPHONE NUMBER: (800) 424-9300

ADDRESS (NUMBER, STREET, CITY, STATE, ZIP): 2797 Freedland Rd.  
Hermitage, Pa. 16148

CHEMICAL NAME AND SYNONYMS: CAMPBELL SCIENTIFIC CS705 ANTIFREEZE

TRADE NAME AND SYNONYMS: Same as above.

CHEMICAL FAMILY: Solvent blend.

FORMULA: Mixture

DATE OF PREPARATION: 09/26/97

REVISION DATE: N/A

PREPARED BY: Erik S. Bielata, Chemist

ICC MSDS #: IC-00891

DISCLAIMER: All information contained in this data sheet is believed to be true and accurate at this time. However, there is no guarantee expressed or implied. The physical data has been calculated from available information.

## 3 — Section II – Hazardous Ingredients

| COMPONENT:          | CAS #:  | VOL % | TLV (units) |
|---------------------|---------|-------|-------------|
| INTERSOL 84 200 PF. | MIXTURE | <55%  | 1000 ppm    |
| 1, 2 – PROPANEDIOL  | 57-55-6 | <55%  | N/A         |

|  |                          |        |
|--|--------------------------|--------|
| Interstate Chemical Co.<br>MSDS for CAMPBELL SCIENTIFIC CS705 ANTIFREEZE | Date Printed: 09-26-1997 | Page 2 |
|  |                          | 1899-- |

**4 — Section III – Physical Data**

BOILING POINT (INDICATE IF “F” OR “C”): 174-212 F VAPOUR

PRESSURE (mm Hg): 23 @ R.T.

VAPOUR DENSITY (AIR = 1): 2.1

SPECIFIC GRAVITY (H2O=1): 0.9164

PERCENT VOLATILE BY VOLUME (%): 100% EVAPORATION RATE

(But Ac = 1): 1.7

SOLUBILITY IN WATER: Complete

APPEARANCE AND ODOUR: Clear, colourless, liquid; mild odour.

**5 — Section IV – HMIS Rating**

|        |              |            |
|--------|--------------|------------|
| HEALTH | FLAMMABILITY | REACTIVITY |
| 2      | 4            | 0          |

0 = Minimal    1 = Slight    2 = Moderate    3 = Serious    4 = Severe

**6 — Section V – Figure and Explosion Hazard Data**

FLASH POINT (METHOD USED): 68 F (TCC)

FLAMMABLE LIMITS: Volume % in Air

LEL: 3.0

UEL: 15.8

EXTINGUISHING MEDIA:

Use water spray, carbon dioxide, dry chemical, or alcohol-type foam applied to manufacturer’s recommended techniques.

SPECIAL FIRE FIGHTING PROCEDURES:

Use self-contained breathing apparatus and protective clothing.

Interstate Chemical Co.  
MSDS for CAMPBELL SCIENTIFIC CS705 ANTIFREEZE

Date Printed: 09-26-1997 Page 3

1899--

#### 6 — Section V – Fire and Explosion Hazard Data (continued)

##### UNUSUAL FIRE AND EXPLOSION HAZARDS:

Vapours form from this product and may travel or be moved by air currents and ignited by pilot lights or other ignition sources.

#### 7 — Section VI – Health Hazard Data

THRESHOLD LIMIT VALUE: See sect. II.

##### EFFECTS OF ACUTE OVEREXPOSURE:

**EYE CONTACT:** Liquid may cause discomfort w/ slight excess redness and possible swelling of the conjunctiva; corneal injury may occur.

**SKIN CONTACT:** Frequent or prolonged contact may cause discomfort and local redness.

**INHALATION:** May cause drowsiness, dizziness, disturbances of vision; tingling, numbness, and shooting pains in the hands and forearms.

**INGESTION:** May cause nausea, abdominal pain, vomiting, headache, dizziness, shortness of breath, weakness, fatigue, leg cramps, confusion, restlessness, visual disturbances, drunken behaviour, drowsiness, coma, and death (THERE MAY BE A DELAY OF SEVERAL HOURS BETWEEN SWALLOWING METHANOL AND THE ONSET OF SIGNS OF ANY SYMPTOMS).

- Visual effects include blurred vision, diplopia, changes in color perception, restriction of visual fields, and complete blindness.
- Ingestion of moderate quantities of methanol also produces metabolic acidosis; onset of symptoms may be delayed up to 48 hrs.
- ❖ 60 – 200 mL OF METHANOL IS A FATAL DOSE FOR MOST ADULTS. INGESTION OF AS LITTLE AS 10 mL HAS CAUSED BLINDNESS.
- With massive overdoses, liver, kidney, and heart muscle injuries have been described.

Interstate Chemical Co.  
MSDS for CAMPBELL SCIENTIFIC CS705 ANTIFREEZE

Date Printed: 09-26-1997 Page 4

1899--

**7 — Section VI – Health Hazard Data (continued)**

**EFFECTS OF REPEATED OVEREXPOSURE:**

- Long-term repeated overexposure to methanol vapour concentrations of 3000 ppm or greater may allow a cumulative effect to occur w/ resulting nausea, vomiting, headache, ringing in the ears, insomnia, trembling, unsteady gait, vertigo, clouded double vision.
- Liver and kidney damage may occur, especially when overexposed to ethanol, which may cause liver injury w/ fibrosis.
- Due to its defatting properties, methanol may aggravate an existing skin condition, e.g. eczema; methanol may also aggravate existing liver and kidney diseases.

**OTHER HEALTH HAZARDS:**

- Repeated ingestion of ethanol by pregnant mothers has been shown to adversely effect the CNS of the fetus, producing a collection of effects which together constitute the fetal alcohol syndrome. Symptoms include mental and physical retardation, learning disorders, motor and language deficiencies, behavioural disorders, and small size head.

**EMERGENCY AND FIRST AID PROCEDURES:**

**EYE CONTACT:** Flush eyes with large amounts of water until irritation subsides. If irritation persists, get medical attention.

**SKIN CONTACT:** Immediately flush with large amounts of water; use soap if available. Remove contaminated clothing, including shoes, after flushing has begun.

**INHALATION:** Using proper respiratory protection, immediately remove the affected victim to fresh air. Administer artificial respiration if breathing has stopped. Keep at rest, Call for prompt medical attention.

**INGESTION:** If swallowed, DO NOT induce vomiting. Keep at rest. Get prompt medical attention. Small amounts which accidentally enter the mouth should be rinsed until taste is gone.

Interstate Chemical Co.  
MSDS for CAMPBELL SCIENTIFIC CS705 ANTIFREEZE

Date Printed: 09-26-1997 Page 5

1899--

**8 — Section VII – Reactivity Data**

STABILITY (choose one): ( ) UNSTABLE  
(x) STABLE

\* CONDITIONS TO AVOID: None.

INCOMPATIBILITY (MATERIALS TO AVOID): Strong oxidizers, strong inorganic acids.

HAZARDOUS DECOMPOSITION PRODUCTS: CO AND CO<sub>2</sub>

HAZARDOUS POLYMERIZATION (choose one): ( ) MAY OCCUR  
(x) WILL NOT OCCUR

\* CONDITIONS TO AVOID: None.

**9 — Section VIII – Spill or Leak Procedures**

STEPS TO BE TAKEN IN CASE MATERIAL IS RELEASED OR SPILLED: Contain spill; provide adequate ventilation; keep people away; EXTINGUISH ALL IGNITION SOURCES; keep material out of public waters; use dry absorbent on small spills.

WASTE DISPOSAL METHOD: Dispose of according to all federal, state and local regulations.

**10 — Section IX – Special Protection Information**

RESPIRATORY PROTECTION (SPECIFY TYPE): NIOSH approved organic vapour cartridge.

VENTILATION:

LOCAL EXHAUST: preferred  
MECHANICAL (GENERAL): acceptable  
SPECIAL: N/A  
OTHER: N/A

PROTECTIVE GLOVES: Rubber or neoprene.

EYE PROTECTION: Safety glasses or goggles.

OTHER PROTECTIVE EQUIPMENT: Rubber apron and boots; eye bath, safety shower.

|  |                          |        |
|--|--------------------------|--------|
| Interstate Chemical Co.<br>MSDS for CAMPBELL SCIENTIFIC CS705 ANTIFREEZE | Date Printed: 09-26-1997 | Page 6 |
|  |                          | 1899-- |

**11 — Section X – Shipping Data**

D.O.T. SHIPPING NAME: FLAMMABLE LIQUIDS, N.O.S.  
(contains Ethanol)

PRODUCT NAME: CAMPBELL SCIENTIFIC CS705 ANTIFREEZE

D.O.T. HAZARD CLASS: 3

U.N./N.A. NUMBER: UN-1993 (PG II)

PRODUCT RQ: N/A/

D.O.T. LABEL: FLAMMABLE

D.O.T. SUBSIDIARY LABEL: N/A

D.O.T. PLACARD: FLAMMABLE

**12 — Section XI – Special Precautions**

PRECAUTIONS TO BE TAKEN IN HANDLING AND STORING:

\*\*\*DANGER!!! May cause eye damage and blindness if swallowed.

- FLAMMABLE
- Harmful if inhaled
- Harmful if absorbed through skin
- Causes eye irritation
- May cause drowsiness, dizziness
- May cause heart muscle damage
- May cause liver and kidney damage
- DO NOT SWALLOW
- Keep away from heat, sparks, flame
- Avoid breathing vapour
- DO NOT get on skin, on clothing
- Avoid contact w/ eyes
- Keep container closed
- Use w/ adequate ventilation
- Wash thoroughly after handling

OTHER PRECAUTIONS: FLAMMABLE LIQUID – Clean equipment thoroughly prior to maintenance and/or repair.

PROCESS HAZARD – Sudden release of hot organic chemical vapours or mists from equipment operating at elevated temperature and pressure, or sudden ingress of air into vacuum equipment, may result in ignitions w/ out the presence of obvious ignition sources. ANY USE OF THIS PRODUCT IN ELEVATED-TEMPERATURE PROCESSES SHOULD BE THOROUGHLY EVALUATED TO ESTABLISH AND MAINTAIN SAFE OPERATING CONDITIONS.

Interstate Chemical Co.  
MSDS for CAMPBELL SCIENTIFIC CS705 ANTIFREEZE

Date Printed: 09-26-1997 Page 7

1899--

**12 — Section XI – Special Precautions (continued)**

TRANSFER HAZARD – Vapours of this product may be ignited by static sparks.

**13 — Section XII – SARA Title III**

This product contains the following toxic chemical that is claimed as a trade secret, but disclosed as an upper bound concentration to comply with the reporting requirements of Section 313 of the Emergency Planning and Community Right-to-Know Act of 1986 and of 40 CFR Part 372.

\*\*METHANOL (CAS #67-56-1) ---- <5%

**14 — Section XIII – Section Revisions**

Revisions have been made to the following sections:







## Campbell Scientific Companies

---

**Campbell Scientific, Inc.**

815 West 1800 North  
Logan, Utah 84321  
UNITED STATES

[www.campbellsci.com](http://www.campbellsci.com) • [info@campbellsci.com](mailto:info@campbellsci.com)

**Campbell Scientific Canada Corp.**

14532 – 131 Avenue NW  
Edmonton AB T5L 4X4  
CANADA

[www.campbellsci.ca](http://www.campbellsci.ca) • [dataloggers@campbellsci.ca](mailto:dataloggers@campbellsci.ca)

**Campbell Scientific Africa Pty. Ltd.**

PO Box 2450  
Somerset West 7129  
SOUTH AFRICA

[www.campbellsci.co.za](http://www.campbellsci.co.za) • [cleroux@csafrica.co.za](mailto:cleroux@csafrica.co.za)

**Campbell Scientific Centro Caribe S.A.**

300 N Cementerio, Edificio Breller  
Santo Domingo, Heredia 40305  
COSTA RICA

[www.campbellsci.cc](http://www.campbellsci.cc) • [info@campbellsci.cc](mailto:info@campbellsci.cc)

**Campbell Scientific Southeast Asia Co., Ltd.**

877/22 Nirvana@Work, Rama 9 Road  
Suan Luang Subdistrict, Suan Luang District  
Bangkok 10250  
THAILAND

[www.campbellsci.asia](http://www.campbellsci.asia) • [info@campbellsci.asia](mailto:info@campbellsci.asia)

**Campbell Scientific Ltd.**

Campbell Park  
80 Hathern Road  
Shepshed, Loughborough LE12 9GX  
UNITED KINGDOM

[www.campbellsci.co.uk](http://www.campbellsci.co.uk) • [sales@campbellsci.co.uk](mailto:sales@campbellsci.co.uk)

**Campbell Scientific Australia Pty. Ltd.**

PO Box 8108  
Garbutt Post Shop QLD 4814  
AUSTRALIA

[www.campbellsci.com.au](http://www.campbellsci.com.au) • [info@campbellsci.com.au](mailto:info@campbellsci.com.au)

**Campbell Scientific Ltd.**

3 Avenue de la Division Leclerc  
92160 ANTONY  
FRANCE

[www.campbellsci.fr](http://www.campbellsci.fr) • [info@campbellsci.fr](mailto:info@campbellsci.fr)

**Campbell Scientific (Beijing) Co., Ltd.**

8B16, Floor 8 Tower B, Hanwei Plaza  
7 Guanghua Road  
Chaoyang, Beijing 100004  
P.R. CHINA

[www.campbellsci.com](http://www.campbellsci.com) • [info@campbellsci.com.cn](mailto:info@campbellsci.com.cn)

**Campbell Scientific Ltd.**

Fahrenheitstraße 13  
28359 Bremen  
GERMANY

[www.campbellsci.de](http://www.campbellsci.de) • [info@campbellsci.de](mailto:info@campbellsci.de)

**Campbell Scientific do Brasil Ltda.**

Rua Apinagés, nbr. 2018 – Perdizes  
CEP: 01258-00 – São Paulo – SP  
BRASIL

[www.campbellsci.com.br](http://www.campbellsci.com.br) • [vendas@campbellsci.com.br](mailto:vendas@campbellsci.com.br)

**Campbell Scientific Spain, S. L.**

Avda. Pompeu Fabra 7-9, local 1  
08024 Barcelona  
SPAIN

[www.campbellsci.es](http://www.campbellsci.es) • [info@campbellsci.es](mailto:info@campbellsci.es)

Please visit [www.campbellsci.com](http://www.campbellsci.com) to obtain contact information for your local US or international representative.