

# ***RAIN BIRD***

**Weather Station - Model - PRO**

**INSTALLATION  
MAINTENANCE  
AND  
TROUBLESHOOTING  
MANUAL**



# *RAIN BIRD*

## **Weather Station – Model – PRO**

---

### *Table of Contents*

<u><i>Description</i></u>	<u><i>Page</i></u>
<i>1.0 General</i>	<i>1</i>
<i>2.0 Tools &amp; Supplies</i>	<i>2</i>
<i>Tools Required</i>	<i>2</i>
<i>Supplies Required</i>	<i>2</i>
<i>3.0 Weather Station Site Selection</i>	<i>3</i>
<i>Temperature/Relative Humidity</i>	<i>4</i>
<i>Solar Radiation</i>	<i>4</i>
<i>Precipitation</i>	<i>5</i>
<i>Determining True North for Wind Vane Operation.</i>	<i>5</i>
<i>Prompts from Geomag</i>	<i>7</i>
<i>4.0 Weather Station Concrete Base</i>	<i>9</i>
<i>Supplied Components</i>	<i>9</i>
<i>Installer Supplied</i>	<i>9</i>
<i>Tools Required</i>	<i>9</i>
<i>Installation</i>	<i>9</i>
<i>5.0 External Wiring to Weather Station</i>	<i>12</i>
<i>Wiring Valve Access Box</i>	<i>12</i>
<i>Weather Station Power Wiring</i>	<i>12</i>
<i>Weather Station Communication Wiring (JR-SH)</i>	<i>13</i>
<i>Grounding Communication Cable</i>	<i>13</i>
<i>Weather Station Communication Wiring (JR-PH)</i>	<i>15</i>
<i>6.0 Tower Assembly and Installation</i>	<i>15</i>
<i>Supplied Components</i>	<i>15</i>
<i>Installation</i>	<i>15</i>
<i>7.0 ET Instrumentation Enclosure Installation</i>	<i>18</i>
<i>General</i>	<i>18</i>
<i>Mounting ET Enclosure to the Tower</i>	<i>18</i>

## **Table of Contents - Cont'd.**

<u><b>Description</b></u>	<u><b>Page</b></u>
<i>Installation of Lightning Rod</i> . . . . .	19
<i>Power Supply Rechargeable Battery.</i> . . . . .	19
<i>AC External Power Wiring</i> . . . . .	21
<i>Power Supply Option Solar Panel</i> . . . . .	22
<b>8.0 Installation of Instrumentation</b> . . . . .	<b>24</b>
<i>General</i> . . . . .	24
<i>Supplied Components</i> . . . . .	24
<i>Installation of Cross-Arm to ET Enclosure</i> . . . . .	24
<i>Installation of 034A Wind Sensor</i> . . . . .	26
<i>Installation of Relative Humidity/Temperature</i> <i>Sensor and Radiation Shield.</i> . . . . .	28
<i>Installation of Solar Radiation Pyranometer</i> . . . . .	29
<i>Sensor Cable Connections</i> . . . . .	30
<i>Configure Sensor Switch Settings</i> . . . . .	31
<i>Upgrading a "JR" weather station to a "PRO"</i> . . . . .	31
<i>Sensor Verification and Clock Set</i> . . . . .	33
<i>Short Haul Modem Installation</i> . . . . .	33
<i>Telephone Modem Installation</i> . . . . .	35
<b>9.0 Sealing &amp; Desiccating the Enclosure</b> . . . . .	<b>36</b>
<b>10.0 Installation at Central Computer</b> . . . . .	<b>37</b>
<i>Supplied Components</i> . . . . .	37
<i>Installation</i> . . . . .	37
<i>Model JR-PH ~ Phone Connected</i> . . . . .	40
<i>Supplied Components</i> . . . . .	40
<i>Installation - General.</i> . . . . .	40
<i>Standard Installation Method</i> . . . . .	40
<b>11.0 Maintenance &amp; Troubleshooting</b> . . . . .	<b>42</b>
<i>General Maintenance</i> . . . . .	42
<i>Instrumentation Maintenance</i> . . . . .	42
<i>Batteries</i> . . . . .	42
<i>Rechargeable Battery.</i> . . . . .	42
<i>Desiccant</i> . . . . .	42
<i>Sensor Maintenance</i> . . . . .	42



**Table of Contents - Cont'd.**

<b><u>Description</u></b>	<b><u>Page</u></b>
<b>1 Week</b> . . . . .	<b>42</b>
<b>1 Month</b> . . . . .	<b>43</b>
<b>6 Months</b> . . . . .	<b>43</b>
<b>1 Year</b> . . . . .	<b>43</b>
<b>2 Years</b> . . . . .	<b>43</b>
<b>3 Years</b> . . . . .	<b>43</b>
<b>4-5 Years</b> . . . . .	<b>43</b>
<b>General Maintenance</b> . . . . .	<b>43</b>
<b>Sensor Maintenance</b> . . . . .	<b>44</b>
<b>Rain Gage</b> . . . . .	<b>44</b>
<b>Calibrating a Rain Bucket</b> . . . . .	<b>44</b>
<b>Suggestions</b> . . . . .	<b>44</b>
<b>Solar Sensor</b> . . . . .	<b>45</b>
<b>Wind Sensor</b> . . . . .	<b>45</b>
<b>Relative Humidity Sensor</b> . . . . .	<b>45</b>
<b>Temperature Sensor</b> . . . . .	<b>46</b>
<b>Other Maintenance</b> . . . . .	<b>46</b>
<b>Seal of ET Enclosure</b> . . . . .	<b>46</b>
<b>Battery Check</b> . . . . .	<b>47</b>
<b>Sensor Testing</b> . . . . .	<b>47</b>
<b>Wind Speed Sensor</b> . . . . .	<b>48</b>
<b>Wind Direction Sensor</b> . . . . .	<b>48</b>
<b>Solar Radiation Sensor (Pyranometer)</b> . . . . .	<b>48</b>
<b>Tipping Bucket Rain Gage</b> . . . . .	<b>48</b>
<b>Temperature/Relative Humidity Sensor</b> . . . . .	<b>49</b>
<b>Troubleshooting</b> . . . . .	<b>50</b>
<b>Isolating the Problem</b> . . . . .	<b>50</b>
<b>Checking the Weather Station</b> . . . . .	<b>50</b>
<b>Using the ML 10-KD Keyboard Display</b> . . . . .	<b>50</b>
<b>Datalogger Location Table</b> . . . . .	<b>51</b>
<b>Troubleshooting Problems</b> . . . . .	<b>51</b>
<b>No display on the ML 10-KD keyboard</b> . . . . .	<b>51</b>
<b>No response using the keyboard and/or erroneous letters in the display</b> . . . . .	<b>52</b>

## **Table of Contents - Cont'd.**

<u><b>Description</b></u>	<u><b>Page</b></u>
<i>No Response from Datalogger through SC32A or Modem Peripheral.</i> . . . . .	52
<i>At the datalogger</i> . . . . .	52
<i>At the computer</i> . . . . .	52
<i>-99999 Displayed in an Input Location</i> . . . . .	53
<i>Unreasonable Results Displayed in an Input Location</i> . . . . .	53
<i>6999 or 99999 Stored in Final Storage</i> . . . . .	53
 <i>Using a Laptop Computer</i> . . . . .	 53
 <i>Checking the Communications Wire Path</i> . . . . .	 54
<i>Loop Resistance</i> . . . . .	54
<i>Ground Resistance</i> . . . . .	54
<i>WS-PRO-SH Direct Connect Weather Station</i> . . . . .	54
<i>Weather Station will not answer</i> . . . . .	54
<i>Checking the RAD modem</i> . . . . .	55
<i>Checking the Communication Wire Path</i> . . . . .	56
<i>WS-PRO-PH Phone Connect Weather Station</i> . . . . .	57
<i>Weather Station will not answer</i> . . . . .	57
 <i>Computer Modem &amp; Communication Troubleshooting</i> . . . . .	 58
<i>Weather Software will not communicate with the weather station</i> . . . . .	58
<i>Testing the Short Haul Modem</i> . . . . .	58
<i>Testing the Phone Modem</i> . . . . .	59

## Appendix

<u>Description</u>	<u>Page</u>
<i>Upgrading the Model JR Weather Station to a Model PRO Weather Station</i> . . . . .	<i>60</i>
<i>Typical 3-Rod Grounding Grid</i> . . . . .	<i>60</i>
<i>Ground Resistance</i> . . . . .	<i>61</i>
<i>Bentonite Contact</i> . . . . .	<i>61</i>
<i>Rocky Conditions</i> . . . . .	<i>61</i>
<i>Rock Layer</i> . . . . .	<i>61</i>
<i>Improving Earth Grounds</i> . . . . .	<i>62</i>
<i>MSP-1 Pipe Surge Arrestors</i> . . . . .	<i>62</i>

## Table of Figures

<u>Figure #</u>	<u>Description</u>	<u>Page</u>
#1	<i>Effect of Structure on Wind Flow . . . . .</i>	4
#2	<i>Magnetic Declination for the Contiguous United States . . . . .</i>	6
#3	<i>Declination Angles . . . . .</i>	8
#4	<i>Concrete Base Detail . . . . .</i>	11
#5	<i>Anchor Bolt/Template Detail. . . . .</i>	11
#6	<i>External Wiring Detail at the PRO-SH Station . . . . .</i>	14
#7	<i>External Wiring Detail at the PRO-PH Station . . . . .</i>	17
#8	<i>Mounting ET Enclosure on Tower . . . . .</i>	18
#9	<i>16VAC Connection &amp; Rechargeable Battery Installation . . . . .</i>	20
#10	<i>Solar Pane Installation Detail . . . . .</i>	23
#11	<i>Cross-Arm Mounting Detail . . . . .</i>	25
#12	<i>Wind Sensor Installation Detail . . . . .</i>	27
#13	<i>Temperature/RH Sensor Installation Detail. . . . .</i>	28
#14	<i>Solar Radiation Sensor Installation Detail . . . . .</i>	29
#15	<i>Sensor Cable Connections . . . . .</i>	30
#16	<i>Sensor Switch Settings . . . . .</i>	31
#17	<i>Upgrading a "JR" to a "PRO" Weather Station . . . . .</i>	32
#18	<i>Short Haul Modem Installation in ET Enclosure . . . . .</i>	34
#19	<i>Telephone Modem Installation in ET Enclosure . . . . .</i>	36

**Table of Figures Cont'd.**

<b><u>Figure #</u></b>	<b><u>Description</u></b>	<b><u>Page</u></b>
#20	<i>Desiccant Pack Installation . . . . .</i>	36
#21	<i>Installation at Central Computer for Direct Connected Weather Station . . . . .</i>	39
#22	<i>Installation at Central Computer for Telephone Connected Weather Station . . . . .</i>	41
#23	<i>Using the ML 10-KD Keyboard Display . . . . .</i>	50
#24	<i>Configuration of Serial Cable . . . . .</i>	53
#25	<i>Test of Short Haul Modem . . . . .</i>	55
#26	<i>Test of Communication Wires . . . . .</i>	56
#27	<i>Upgrade Kit . . . . .</i>	60
#28	<i>Typical 3-Rod Grounding Grid Detail . . . . .</i>	63
#29	<i>Testing of Wind Sensor . . . . .</i>	64
#30	<i>Testing of Solar Radiation Sensor . . . . .</i>	65
#31	<i>Testing of Rain Gage . . . . .</i>	66
#32	<i>Testing of Temperature/RH Sensor . . . . .</i>	67
#33	<i>Testing of Air Temperature Probe . . . . .</i>	68



# **RAIN BIRD**

## **Weather Station -- Model - PRO**

### **1.0 GENERAL:**

The Rain Bird "Model PRO" Weather Station, when used in conjunction with the Rain Bird MAXI 5, MAXI "Nimbus" or MAXI "Cirrus" Central Control system, provides the irrigation manager with a powerful tool to aid in the growing of lush, healthy, green turfgrass, while conserving important resources, such as water, power, etc.

The MAXI 5, MAXI Nimbus or MAXI Cirrus software interrogates the Weather Station to gather information that has been gathered on a daily basis, on 5 second intervals for short haul modem only, of the climatic conditions that affect the irrigation application for the area.

The MAXI 5, MAXI Nimbus or MAXI Cirrus software subjects the climatic information that it gathers to a version of the modified Penman Equation. The Penman Equation has been proven through over 35 years of university research, to be one of the most reliable predictors of turfgrass water use requirements.

The Weather Station monitors the following climatic conditions:

- Rainfall
- Wind Speed & Direction
- Air Temperature
- Relative Humidity
- Solar Radiation

The basic PRO Weather Station configuration includes sensors to monitor these conditions, a micrologger to capture this data, a modem to communicate the information to the MAXI Central Computer and a power supply.

The Rain Bird Model "PRO" Weather Station is available in two (2) basic configurations;

Model PRO-SH, which is a direct wire system intended for use when the weather station is within 20,000 feet of the MAXI Central Computer and communication is via a wire path, between the weather station and the computer.

Model PRO-PH, which is a phone modem system for use when the weather station is further than 20,000 feet from the MAXI Central Computer or

when they cannot be connected by a communication wire path. The system communicates utilizing a standard, dedicated phone service.

## **2.0 TOOLS & SUPPLIES:** *(Installer Supplied)*

The installer needs access to the following tools and supplies for installation of the Weather Station.

### **TOOLS REQ'D.**

Shovel  
Rake  
Wire Strippers  
Screw driver, regular blade  
Flat Metal File  
Screw driver, thin regular blade  
Wheelbarrow  
Screw driver, Phillips head  
Hand Saw  
Open End Wrench 7/16"  
(2) - Open End Wrench 9/16"  
Open End Wrench 1/2"  
Open End Wrench 3/8"  
Claw Hammer  
Magnetic Compass  
Tape Measure 12' - 20'  
Matr'l. for Concrete Base Form:  
    (4) 12" Wood Stakes  
    (1) 2"x 4"x 10' piece of wood  
    (8) 8p double-head nails  
    (8) 16p double-head nails  
    20 ft. of form wire  
    1/2 yard of concrete  
6 Ft. Step Ladder  
Concrete trowel & edger  
Saw Horse  
Wire  
Fish Tape or small dia. rope

### **SUPPLIES REQ'D.**

- (2) Standard Size (12" x 18") Rectangular Valve Boxes
- (3) MGP-1 Maxi Grounding Plate Assembly
- (5) MSP-1 Maxi Surge Arrestor (Pipe Type) (for "JR-SH" model ONLY).
- (6) 5/8" Dia. X 8'-0" copper clad grounding rods
- #10 Gauge or larger bare copper grounding wire - length as required.
- Brass Grounding Clamps - as required
- (20) 3-M model DBY or DBR Direct Burial splice kits or 3-M Scotch-lok 3500 series Connector Packs.
- Belden #9883 or PE-39 direct burial, communication cable - length as required.
- (2) Lengths of type UF power wire (white and black) - size and length as required.
- (1) 4" x 4" electrical junction box with cover plus connectors as required for transformer mounting.
- (2) Open Spade, crimp-on type connectors - for connecting power wiring to transformer.



### **3.0 WEATHER STATION SITE SELECTION:**

Site selection for the Weather Station is one of the most crucial steps in a successful installation and an efficiently operating irrigation system. The site selection will greatly impact the accuracy of the meteorological data collected by the station. The site selection process has many constraints placed on it, and although the "perfect" site is often non-existent, the following generalities should be kept in mind.

In general, the site should be representative of the general area of interest and reflect the general conditions of the project's turf. The more "typical" the site, in this regard, the more useful will be the information gathered. The site should also be away from the influence of obstructions such as buildings, trees, etc.

The weather station should not be located where sprinkler irrigation water will strike sensors or instrument enclosure. The turf around the weather station needs to be irrigated however - so it is recommended that half-circle sprinklers be placed around the base of the weather station and "throwing OUT" away from the weather station. In this way the turf can be irrigated and at the same time water can be kept off the sensors and instrument enclosure of the weather station.

The sensors of the weather station should be eight (8) to ten (10) feet above the turfgrass. Remember that the roof of a building ***IS NOT*** a good site for the weather station.

The weather station does NOT need to be "hidden". The Rain Bird weather station has been engineered to be aesthetically pleasing. The urge to "hide" the station needs to be balanced with the selection of the most "typical" turfgrass area. The station should NOT negatively impact the turfgrass environment or utility. In fact, many installations prominently display the Weather Station to demonstrate their commitment to water conservation.

If the site may be prone to vandalism, an open, chain-link, 6 foot high security fence with a lockable access gate should be placed around the weather station. The fence shall be a minimum of eight (8) feet out from the weather station on all sides and should be a type that will not interfere with the accuracy of the sensors.

In your selection of a site - try to avoid sites on or near open dirt fields and asphalt parking areas. These sites are prone to high reflective heats that can distort the information. Any areas that are within 90 to 100 feet "up wind" of the weather station can adversely affect the weather station reading accuracies.

The requirements of each weather station sensor must be considered when selecting the proper location for a weather station site. In addition to these generalities, each sensor has its own specialized constraints. While complete information is available, upon special request, for each individual sensor, the following are the highlights of each.

**(a) TEMPERATURE AND RELATIVE HUMIDITY:**

Sensors should be located over an open level turf area at least 30 feet in diameter. The surface should be the typical turfgrass of the area in interest. Sensors should be located a distance away of at least four (4) times the height of any nearby obstruction and at least 90 feet from large paved areas. Sensors should be protected from thermal radiation, and adequately ventilated.

Situations to avoid include:

- large industrial heat sources
- rooftops
- steep slopes
- sheltered hollows
- high vegetation
- shaded areas

- top of a hill
- bottom of a swale
- swamps
- areas where snow drifts occur
- low places holding standing water

**(b) SOLAR RADIATION:**

Pyranometers should be located to avoid shadows on the sensor at any time. Mounting it on the southern most portion (northern hemisphere) of the weather station will minimize the chance of shading from other weather station structures. Reflective surfaces and sources of artificial radiation should be avoided. The height at which the sensor is mounted is not critical.

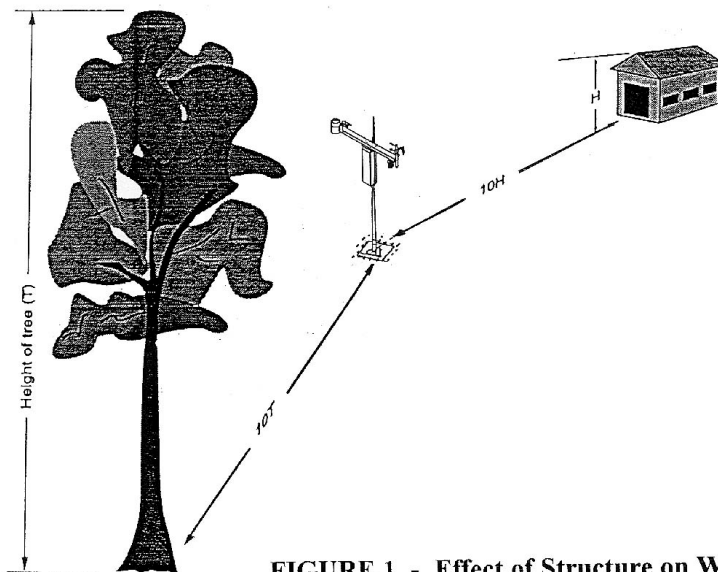

FIGURE 1 - Effect of Structure on Wind Flow

**(c) PRECIPITATION**

A rain gage should be located over level ground that is covered with short grass or gravel. In open areas, the distance to obstructions should be two to four times the height of the obstruction.

The height of the opening should be as low as possible, but should be high enough to avoid splashing from the ground.

The gage must be mounted above the average level of snow accumulation in areas that experience significant snowfall.

Standard measurement heights:

- 1.0 meter +/- 1.0 cm (AASC)
- 30.0 centimeter minimum (WMO, EPA)

(d)

**DETERMINING TRUE NORTH FOR WIND VANE OREINTATION**

Magnetic declination, or other methods to find True North, should be determined prior to installing the

weather station. True North is usually found by reading a magnetic compass and applying the correction for magnetic declination. (Other methods employ observations using the North Star or the sun, and are discussed in the Quality Assurance Handbook for Air Pollution Measurement Systems, Volume IV - Meteorological Measurements.) The magnetic declination is the number of degrees between True North and Magnetic North. Magnetic declination for a specific site can be obtained from a USFA map, local airport, or through a computer service offered by the USFS called GEOMAG (see page 7). A general map showing magnetic declination for the contiguous United States is shown below in FIGURE 2.

Declination angles east of True North are considered negative and are subtracted from 0 degrees to get True North. Declination angles west of True North are considered positive and are added to 0 degrees to get True North. For example, the declination for Logan, Utah is 16 degrees East. True North is 360 degrees minus 16 degrees, or 344 degrees as read on a compass.

---

**REFER TO NEXT PAGE FOR FIGURE 2**

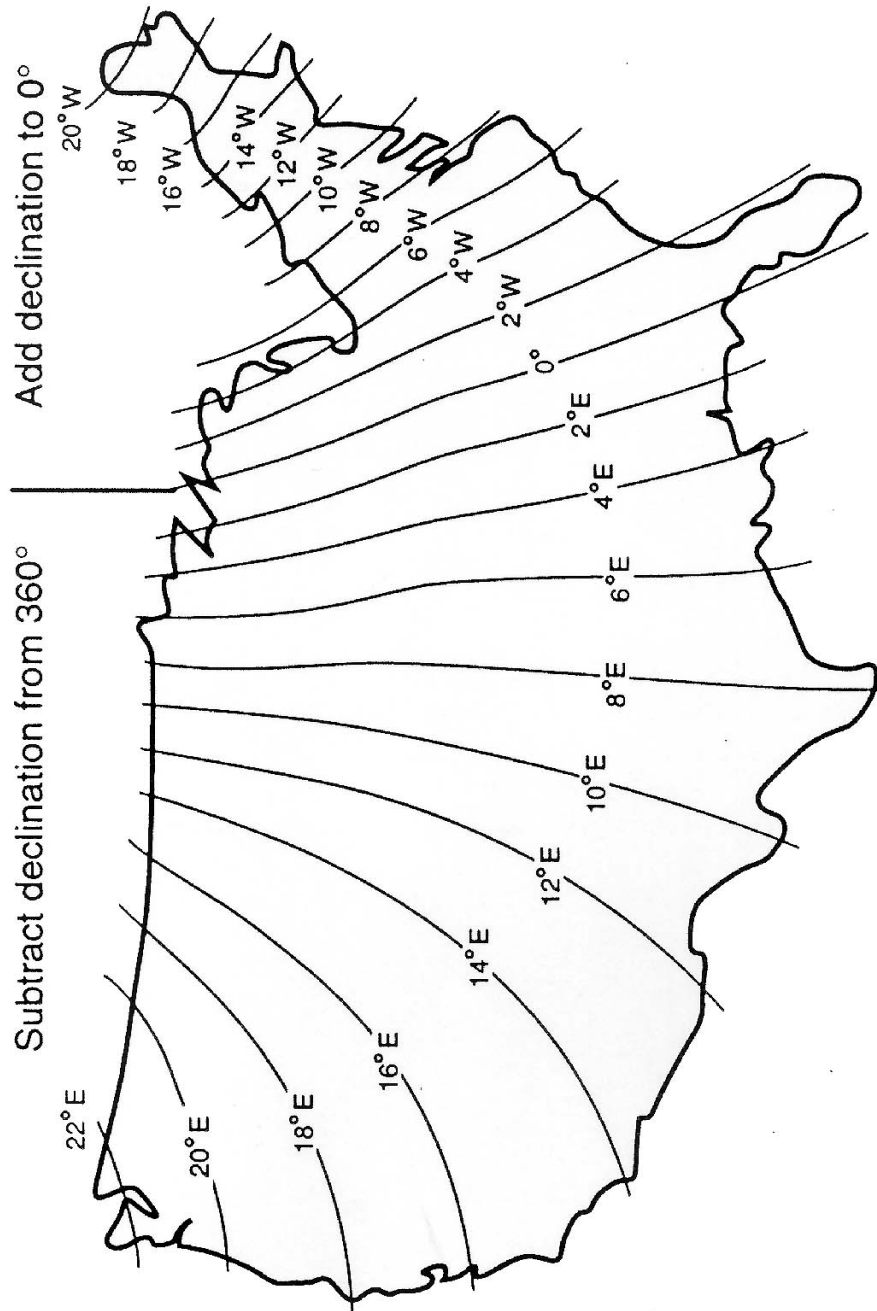

**FIGURE 2 - MAGNETIC DECLINATION FOR THE CONTIGUOUS UNITED STATE**

**PROMPTS FROM GEOMAG**

GEOMAG is accessed by phone with a PC and telephone modem and a communications program such as Pro Comm or Windows 95 Hyperterminal. GEOMAG prompts the caller for site latitude, longitude and elevation, which it uses to determine the magnetic declination and annual change. The following information, menu and prompts are from GEOMAG.

GEOMAG is a user-friendly program that provides estimates of the geomagnetic field elements, including declination and total field intensity, based upon Magnetic Models. The program is accessible by modem or through the Internet.

**Modem Access:**

Modem settings: No parity, 8 data bits and 1 stop bit (i.e., N81).

**Telephone numbers:**

Phone Number	Baud Rates
303-273-8672	2400
303-273-8673	1200
303-273-8678	1200

Upon carrier-signal detection, press Return once or twice.

If you are using one of the commercial numbers, the following prompts will appear. Type the responses shown (followed by pressing RETURN):

GLDSV1> c neis  
[RETURN]  
Username: QED  
[RETURN]

**Main Menu:**

Type  
Q for Quick Epicenter Determinations (QED)  
L for Earthquake Lists (EQLIST)  
M for Geomagnetic Field values (GEOMAG)  
X to log out

ENTER program option: "M"

Would you like information on how to run GEOMAG (Y/N)? Enter N

**OPTIONS:**

- 1 = Field Values (D,I,H,X,Z,F)
- 2 = Magnetic Pole Positions
- 3 = Dipole Axis and Magnitude
- 4 = Magnetic Center [1] : 1

Display values twice [N]: press return  
Name of field model [USCON90]:  
press return  
Date [current date]:  
press return  
Latitude :42/2 N  
Longitude : 111/51/2W  
Elevation : 4454 ft

Example of report generated by  
GEOMAG:

Model: USCON90 Latitude: 42/2 N  
Date: 7/27/93 Longitude: 111/51/2W  
Elevation: 4454.0 ft

Declination is:

deg min  
15 59.6

Annual change:

deg min  
0 -6.1

**EXITING:**

press "Cntrl-Z" to exit GEOMAG

When the main menu reappears either  
select another option or Type "X" to log  
out.

If you used one of the commercial  
numbers, the GLDSV1> prompt will  
reappear.

Type "LO" to disconnect.

Use of GEOMAG is free (except for  
telephone charges). If possible, please  
avoid using GEOMAG between 9 a.m.  
and 4 p.m., mountain time, Monday  
through Friday.

The declination in the example above is  
listed as 15 degrees and 59.6 minutes.  
Expressed in degrees, this would be  
15.99 degrees. As shown in FIGURE 2,  
the declination for Utah is east, so True  
North for this site is 360 - 15.99, or 344  
degrees. The annual change is -6.1  
minutes.

**Refer to FIGURE 3 below:**

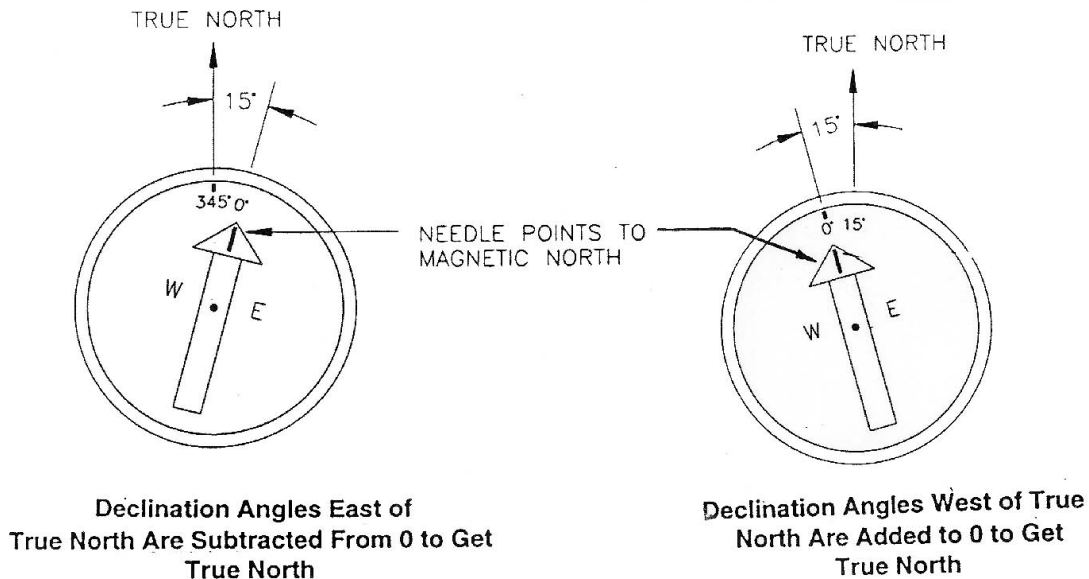

**FIGURE 3 - DECLINATION ANGLES**

**4.0 WEATHER STATION CONCRETE BASE:**

**SUPPLIED COMPONENTS**

- (3) 1/2" x 12" long "L" Anchor Bolts
- (9) 1/2" Nuts
- (3) Flat Steel Washers
- (1) Stainless Steel Template
- (1) 1 1/2" Dia. Long Sweep Elbow

**INSTALLER SUPPLIED**

- (1) 2" x 4" x 10'-0" piece of forming lumber

- (4) 16p Double Headed nails
- 10'-0" length of form wire
- 1/2 yard of concrete
- Duct Tape

**TOOLS REQUIRED**

- Claw Hammer
- Hand Saw
- Saw Horse
- Shovel
- Pliers & Wire Cutters

**INSTALLATION:**

For the following procedures - Refer to **FIGURE 4** below.

**1.0** The Tower for the "PRO" Weather Station - attaches to a user supplied poured concrete foundation - constructed as shown in **FIGURE 4** below.

**2.0** Dig the required foundation hole - with a 24" square top and slanting outward sides, to the bottom of 32" square. The "Sloping" sides of the foundation are very **IMPORTANT** in providing the necessary support to the weather station tower, in preventing it from "leaning" or falling over, due to wind load on the station.

**3.0** Determine the proper location of the long sweep elbow and dig a small cavity

to accept the end of the elbow that will protrude beyond the concrete base.

**4.0** Construct the concrete form with 2" x 4" lumber and 16p double-headed nails. Center the form over the dug hole. Adjacent to the long legs of the form that extend beyond the hole, drive four stakes into the soil. Level the form. Secure the form to the stakes with 8p nails - making sure that the form remains "level".

**5.0** Place a piece of duct tape over one end of the 1 1/2" diameter long sweep elbow. Insert the elbow into the hole, with the taped end into the small cavity that you

have dug on one side of the hole.

**6.0** Insert the other end of the long sweep elbow into the center hole in the stainless steel template. Tape the end of the elbow with duct tape.

**7.0** Take the three ½" x 12" long "L" anchor bolts and install two (2) hex nuts on to each bolt. Insert one in each of the holes in the template and install one of the flat washers and a nut to secure the anchor bolt to the template.

Refer to **FIGURE 5**.

**8.0** Take the form wire and cut it into two (2) equal lengths. Attach one end of one of the wires to one of the 16p nails on the form. String the wire up over the form and to the long sweep elbow - making a turn around it. Continue the wire over to the 16p nail at the other corner of the form (located on the same side of the form as the other nail) and centering the template and elbow attach the wire securely to the nail. Repeat this same process with the other piece of form wire - going to the opposite nails and further securing the

template, elbow and anchor bolts in the form.

**9.0** Steady the template assembly by putting a 2" spacer between the template and the top of the form. Pour the concrete into the hole and form - it will require approximately ½ yard - screed the concrete level with the top of the form. Check to make sure the template is correctly orientated and centered. The bottom of the anchor bolt threads should be about ½" above the top of the concrete. Check to be sure the template is "level" in two (2) dimensions. Use a trowel and edger to finish the concrete.

***BE SURE THAT YOU HAVE THE TEMPLATE PROPERLY ORIENTATED IN RESPECT TO "NORTH". Refer to FIGURE 4.***

The template should have the two (2) bolt holes, that are parallel with one side of the template, on the north side of the base.

**10.0** Wait 24 hours before removing the concrete form. Wait 7 days before mounting the weather station to the base.

**REFER TO NEXT PAGE FOR FIGURES 4 & 5**



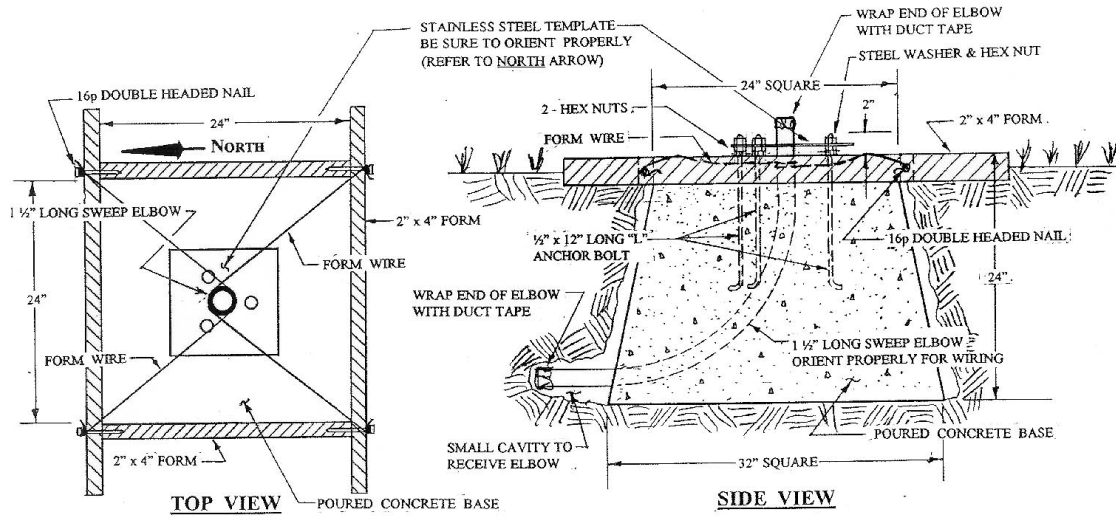

**FIGURE 4 - CONCRETE BASE DETAIL**

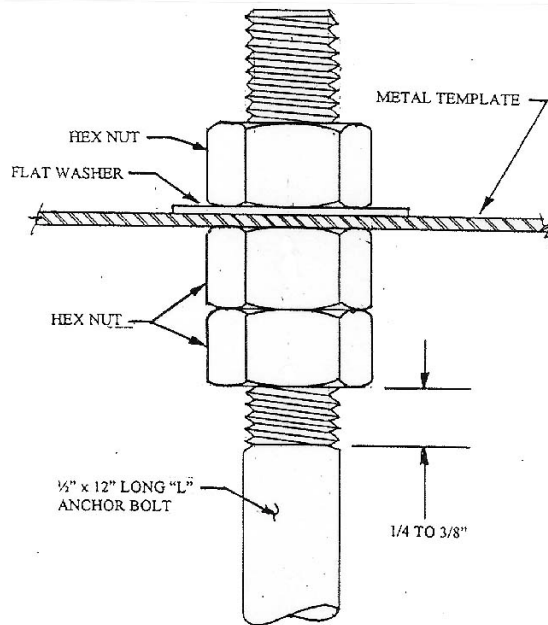

**FIGURE 5 - ANCHOR BOLT/TEMPLATE DETAIL**  
**5.0 EXTERNAL WIRING TO WEATHER STATION: ( Refer to FIGS. 6 & 7)**

**WIRING VALVE ACCESS BOX**

At the base of the Weather Station and as near to the base as feasibly possible, dig a hole large enough to install a standard 18" x 24" rectangular valve box and cover. The valve box shall accommodate all wiring connections, one rod of a 3-rod grounding grid, MGP-1 grounding plate assemblies and MSP-1 surge arrestors.

**WEATHER STATION POWER WIRING**

Furnished as part of the Weather Station is a 120VAC to 16VAC power transformer. This transformer can be located in the pedestal of a field satellite controller that is in the near proximity of the weather station or some other convenient weather proof location. Install the transformer in a 4"x 4" **metal** electrical box with cover. Connect the 120VAC power wires of the transformer to a source of 120VAC power that is not easily turned off. To the output of the transformer, connect a pair of UF wires, of proper size, using "crimp-on" open spade connectors.

The power wires shall be direct buried and run over to the weather station. Connect the 16VAC power wires to the "LINE" side of an MSP-1 surge arrestor, which shall be mounted in an **MGP-1** grounding plate assembly. The MGP-1 grounding plate assembly shall be securely mounted on a 5/8" dia. copper

the weather station, and **MARKED "P/N 9922"**. This cable shall be routed through the 1 1/2" dia. long sweep elbow

clad, ground rod - one of a 3-rod grounding grid.

**NOTE !** The minimum voltage to the transformer shall be not less than 112 volts.

Wire sizing shall be in accordance with the chart given below.

Wire shall be Type "UF" (underground feeder cable) with PVC insulation. The 16VAC power is used to provide constant charging of the battery within the weather station, through the battery charging circuit.

WIRE SIZING CHART	
WIRE SIZE	DISTANCE (feet)*
18	500
16	800
14	1275
12	2000
10	3250
8	5100
* Transformer to Weather Station	

The "EQUIPMENT" side of this MSP-1 surge arrestor shall be connected to "red" and "black" wires of the 20' power wire cable, which is furnished as part of

to the base of the weather station. All wire connections and splices in the power wiring shall be made using 3-M

DBY direct burial connectors. **DO NOT** apply power to transformer at this time.

**WEATHER STATION  
COMMUNICATION WIRING**

**DIRECT CONNECTED - USING  
SHORT HAUL MODEMS:**  
(MODEL PRO-SH - Only)

Coming from the Central location, furnish and install a Belden #9883, Direct Burial Type, communication cable over to the weather station location. The Belden cable shall consist of three (3) twisted pair of wires (20 Gauge), a bare copper drain wire and an aluminum shield. The three (3) twisted pair shall be color coded as follows; 1 pair "black" and "white", 1 pair "black" and "green" and 1 pair "black" and "red".

The BLACK (-XMT) & GREEN (+XMT) pair shall be connected to the BLACK & RED wires respectively, at the "LINE" end of one of the MSP-1 surge arrestors. The BLACK (-XMT) and the RED (+XMT) wires from the "EQUIPMENT" end of this MSP-1 surge arrestor shall be connected to the WHITE (-XMT) and the GREEN (+XMT) wires of the communication cable furnished with the weather station and marked P/N 9720 "ET SHORT HAUL" "COMM".

The RED (+RCV) & BLACK (-RCV) pair shall be connected to the RED & BLACK wires respectively, at the "LINE" end of the other MSP-1 surge arrestor. The RED (+RCV) and the BLACK (-RCV) wires from the "EQUIPMENT" end of this MSP-1 surge arrestor shall be connected to the RED (+RCV) and the BLACK (-RCV) wires of the communication cable furnished with the weather station and marked P/N 9720 "ET SHORT HAUL" "COMM".

This communication cable shall be routed through the 1 1/2" diameter long sweep elbow to the base of the weather station. All wire connections and splices in the communication wiring shall be made using 3-M DBY direct burial connectors. **DO NOT** attempt to use any other type connectors as communication signal may be impaired and poor communication resulting.

**GROUNDING  
COMMUNICATION CABLE**

The bare copper drain wire of the Belden cable shall be grounded to the grounding rod, using a brass ground wire clamp. **IMPORTANT ! DO NOT** ground the drain wire at the Central end of the cable - just leave the drain wire un-used.

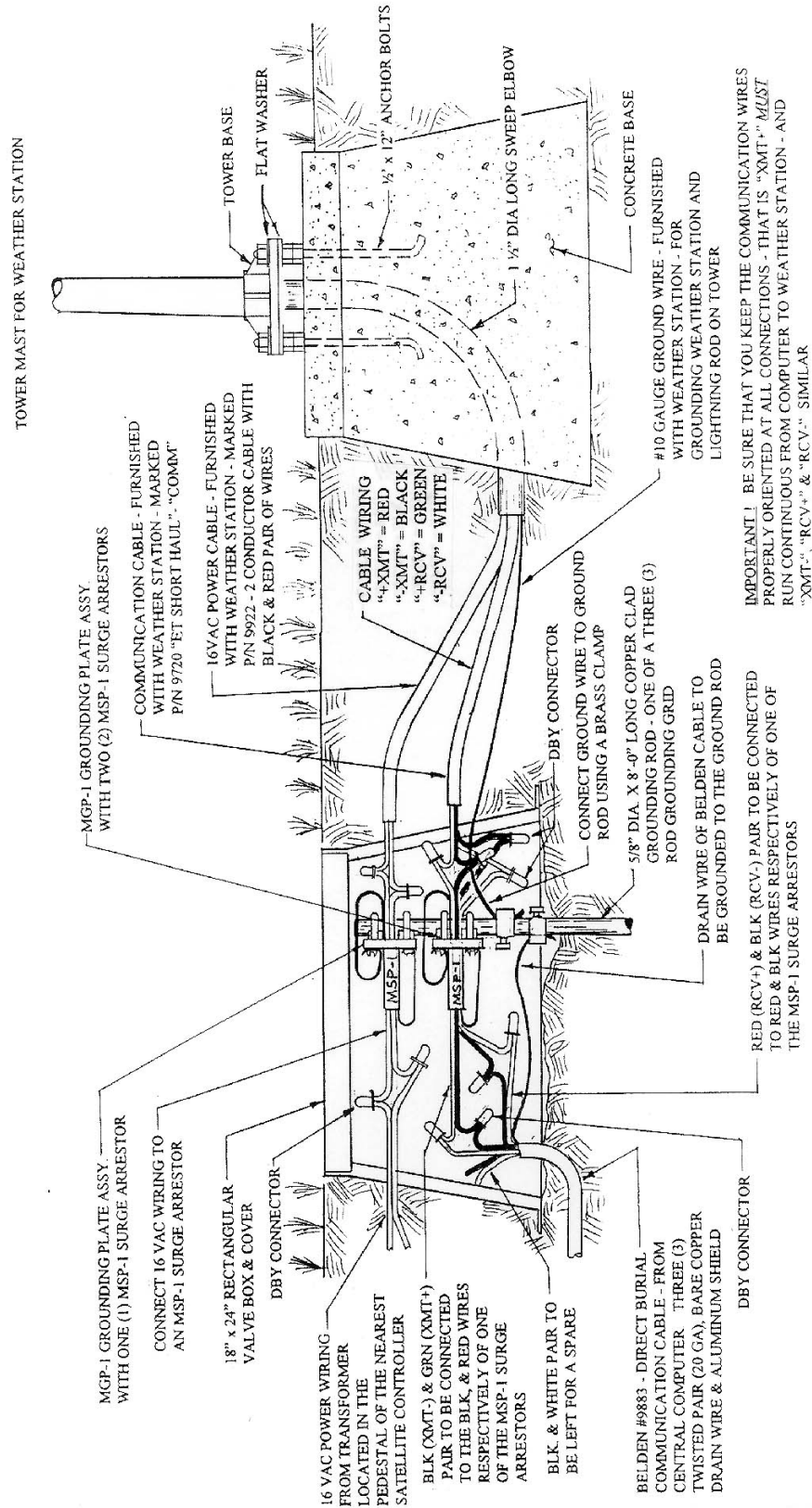

**FIGURE 6 - EXTERNAL WIRING DETAIL AT THE PRO-SH WEATHER STATION**

**WEATHER STATION  
COMMUNICATION WIRING**

**TELEPHONE CONNECTED - USING  
TELEPHONE COMPANY LINES:**  
**(MODEL PRO-PH - Only)**

The Telephone Company needs to run a direct burial telephone cable to the weather station and terminate it near the base of the weather station. This needs to be a modem quality type telephone line with a separate call number.

The "TIP" line of the telephone cable shall be connected to the WHITE ("TIP") wire of a 20' telephone patch cable, furnished as part of the weather station, marked P/N 9661 - 2 conductor cable with WHITE ("TIP") and BLACK ("RING") pair of wires. The "RING" line of the telephone cable shall be

connected to the BLACK ("RING") wire of the telephone patch cable (P/N 9661). Splices shall be made using 3-M DBY Direct Burial connectors. The splices for the phone line shall be made in the valve box, where the power wiring splices are made and where the MGP-1 grounding plate assembly with an MSP-1 surge arrestor mounted in it, is attached to one rod of a 3-rod grounding grid. **Refer to FIGURE 7 below.**

This telephone patch cable (P/N 9661) shall be routed through the 1 1/2" diameter long sweep elbow to the base of the weather station.

---

**6.0 TOWER ASSEMBLY AND INSTALLATION:**

**INSTALLATION**

**SUPPLIED COMPONENTS**

- (1) Upper Tower Section  
(Tapered)
- (2) Lower Tower Section w/Base
- (6) 1/2" Washers
  - (1) 12 foot 10 AWG Ground Cable
  - (1) Tower Plastic Cap

Take the 12 foot 10 AWG Ground Cable, furnished as part of the weather station and cut a 9" piece from on end of it. (This 9" piece will be used later). Attach one end of the ground wire to the ground rod, of the 3-rod grounding grid, that is located in the valve box using a brass clamp. **Refer to FIGURE 6 or 7.**

Feed this ground wire through the 1 1/2" long sweep elbow up to the base of the weather station.

Remove the three (3) "top" nuts and flat washers from the anchor bolts at the weather station template. Next remove the metal template - slipping it up over the cables that are extending from the 1 ½' long sweep elbow. Be careful NOT to damage the cables or the connectors on the cables.

Take the lower section (with the base attached) of the weather station tower and feed, from the base end, the power cable (P/N 9922) up through this section. Also feed, from the base end, the short haul communication cable (P/N 9720 - for the Model JR-SH weather station) or the telephone communication patch cable (P/N 9661 - for the Model JR-PH weather station, up through this section of the tower. Finally feed the ground wire up through the lower section of the tower.

Lay this Lower Section of the tower, on the ground, next to the concrete base, with the cables extending out the top of the tower section.

Take the Upper Section of the tower (the tapered section) and position it above the lower section on the ground. Feed the cables, coming from the lower section, up through the upper section of the tower. Secure the cables at the top of the upper section with tape, so that they cannot pull back down into the tower as you assemble the two tower sections.

Now assemble the upper tower section to lower tower section, being careful NOT to damage the cables as you do so.

**IMPORTANT !** Be sure that you have everything in proper order **BEFORE** you assemble the two tower sections together -because once assembled they cannot be taken apart.

Place one of the flat washers on top of the two (2) nuts on each of the anchor bolts. Raise the tower and position the base on the three (3) anchor bolts that have been embedded in the poured concrete base. Be careful NOT to damage the cables in doing so. Next install a flat washer and a nut on each of the bolts and hand tighten the nuts just enough to hold the tower in position.

Next check the level of the tower by placing a level on the north and east sides of the lower tower base. Adjust the topmost nut of the two (2) lower nuts (leveling nuts) on each bolt, as necessary to level the base. When level is established, lock the leveling nut in place by tightening the lowest nut against it. Tighten the three top nuts with a wrench to secure the tower to the base. The tower should now be ready for the final assembly of the Enclosure, Sensors and Lightning Rod, etc.

**REFER TO NEXT PAGE FOR FIGURE 7**

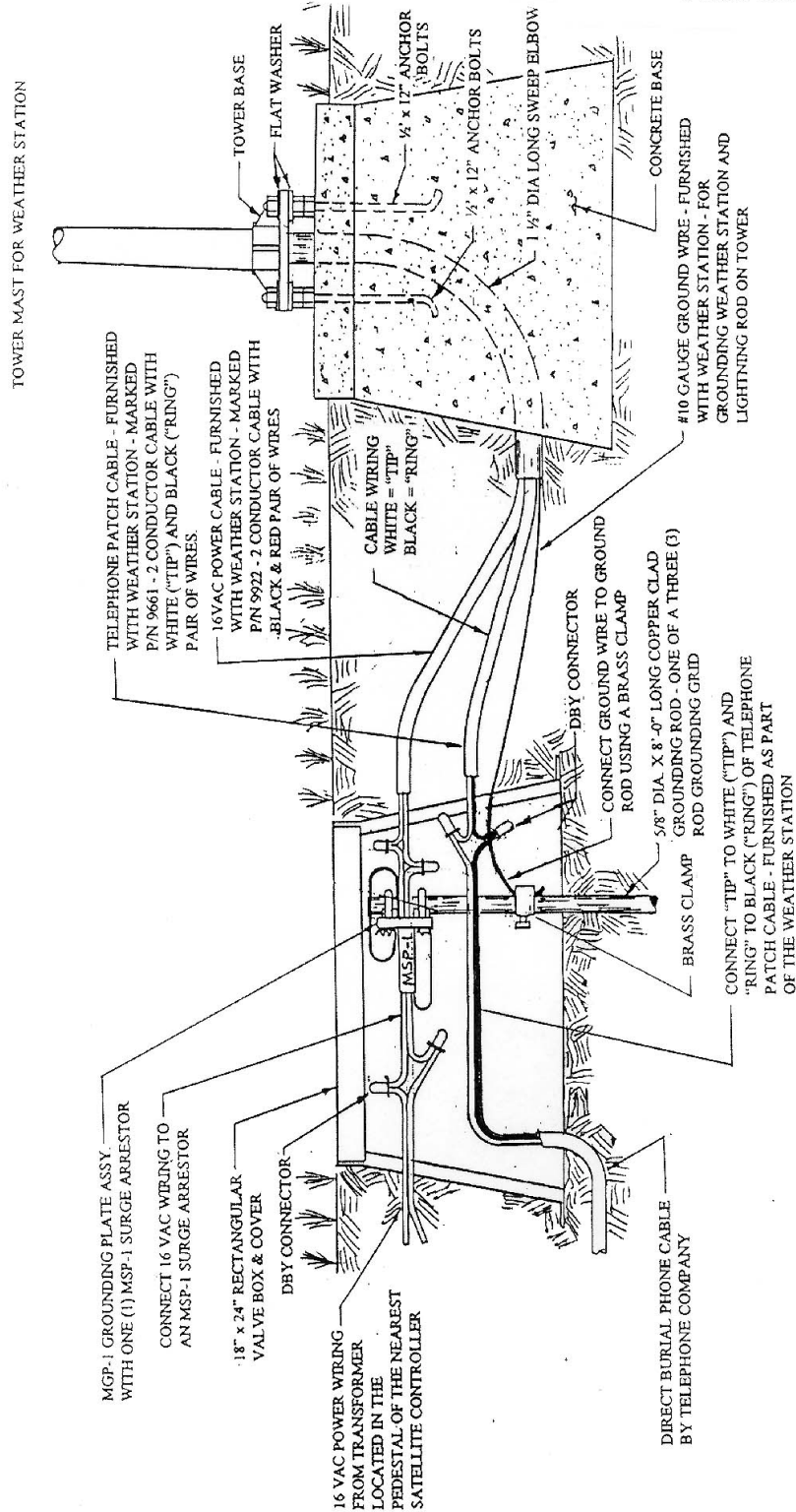

**FIGURE 7 - EXTERNAL WIRING DETAIL AT THE PRO - PH WEATHER STATION**



## 7.0 INSTRUMENTATION ENCLOSURE INSTALLATION:

### GENERAL:

The Model PRO weather station datalogger, power supply, sensor connection panel, communications devices and data retrieval peripherals are mounted in the ET Enclosure with the sensors themselves mounted on a cross-arm, which mounts to the top of the Enclosure.

enclosure brackets down the tower, from the top of the tower.

Position the Enclosure so that the top of the enclosure is even with the top of the tower and on the north side of the tower (for northern hemisphere). Tighten the bolts, on the clamps, to secure the enclosure to the tower. **DO NOT** over-tighten the bolts since doing so may damage the tower or the enclosure.

### MOUNTING ET ENCLOSURE TO THE TOWER

Refer to FIGURE 8 below

Mount the Enclosure to the top of the weather station tower, by sliding the

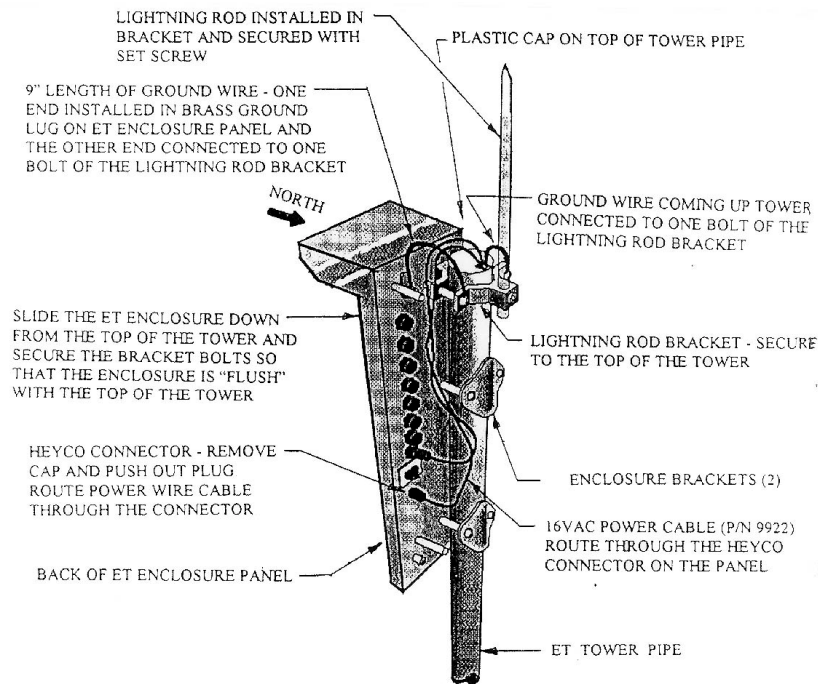

FIGURE 8 - MOUNTING ENCLOSURE ON TOWER



**INSTALLATION OF  
LIGHTNING ROD**

Refer to FIGURE 8 above:

Carefully mount the lightning rod bracket, furnished with the weather station, to the top of the weather station tower. Locate it above the Enclosure top bracket and near the top of the tower. Clearance between the clamp and the Enclosure is minimal. Care should be taken not to scratch the enclosure or sensor assembly. Insert the lightning rod into the bracket, with approximately ½" to 1" of the rod extending below the bracket, and tighten the set screw to secure the rod in the bracket.

Take the ground wire, that has been fed up the weather station tower, strip the insulation from the end and curl the end so as to be able to connect the wire under the head of one of the bolts on the lightning rod bracket. Be sure that you wrap this wire completely around the bolt and that you get a good contact with the bolt and bracket. Tighten the bolt securely so that you have a good tight connection. This connection is **EXTREMELY** important to give maximum protection to the weather station against damage from lightning surges. This connection should be **INSPECTED** on a regular basis to

assure it remains tight and making good contact.

Take the 9" piece of ground wire, that you previously cut off the ground wire, and strip the insulation from each end of it. Insert one end of this wire into the brass grounding lug, located at the top of the Enclosure on the back panel. Tighten the set screw to secure the wire in the clamp. Curl the other end so as to be able to place it around the other bolt of the lightning rod bracket. Be sure that you wrap this wire completely around the bolt and that you get a good contact with the bolt and bracket. Tighten the bolt securely so that you have a good tight connection. This connection is **EXTREMELY** important to give maximum protection to the weather station against damage from lightning surges. This connection should be **INSPECTED** on a regular basis to assure it remains tight and making good contact.

**POWER SUPPLY  
RECHARGEABLE BATTERY**

The weather station is furnished as standard with a Sealed Rechargeable Battery and including the mounting bracket. This battery is to be installed on the back panel of the Enclosure.

Refer to FIGURE 9 below.

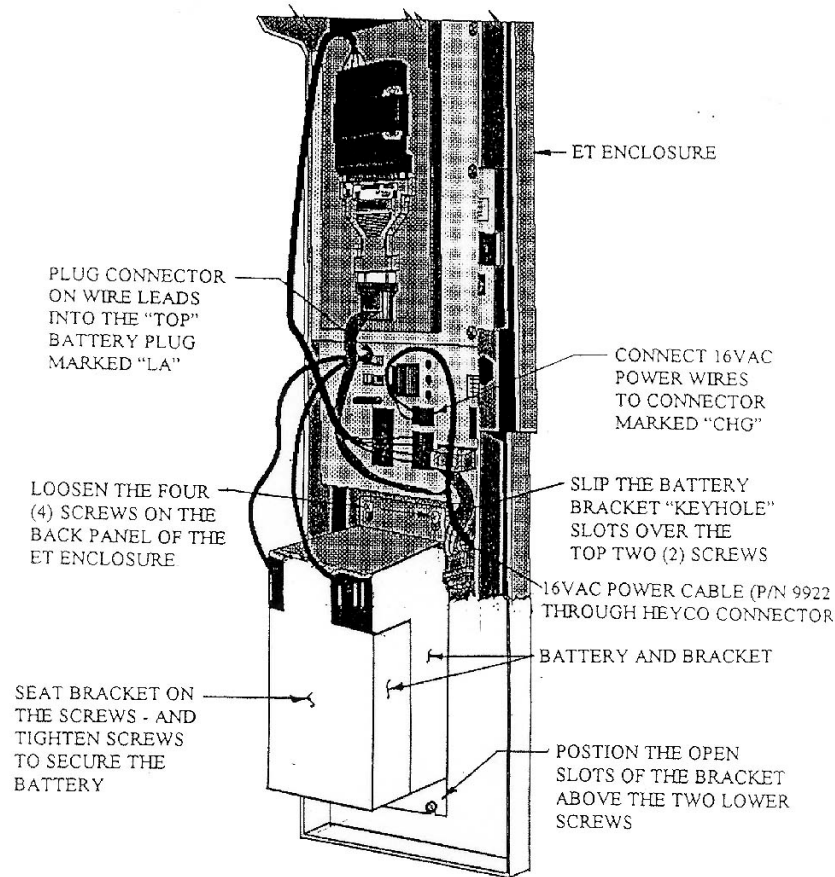

**FIGURE 9 - 16VAC CONNECTION AND RECHARGEABLE BATTERY INSTALLATION**

Loosen the four (4) screws located on the back panel of the Enclosure. Slip the end of the battery bracket, that has the two (2) keyhole slots in it over the upper two (2) screws. Line up the battery bracket slotted holes, in the other end of the bracket, with the two (2) lower screws. Now push "down" on the battery - seating the bracket in place with the screws. Tighten all four screws

to properly secure the battery to the back panel of the ET Enclosure.

Plug the connector on the wire leads of the battery to the "top" battery connection - marked "LA" - which is located on the Enclosure panel assembly just above the battery location.

**AC EXTERNAL  
POWER WIRING**

**Refer to FIGURE 8 & 9 above:**

The 16VAC power wiring, that you have fed up through the weather station tower, shall be routed down the back side of the Enclosure and into the Enclosure through the Heyco fitting, marked "power". Unscrew the cap of the Heyco fitting (on the back side of the enclosure) and push the plug out of the fitting. This plug can be discarded as it will not be used. Feed the power wires through the Heyco fitting and connect them to the the connectors of the Enclosure, marked "CHG". Tighten

the cap on the Heyco fitting to seal around the cable. The wires can be attached to these connectors by "depressing" the lever on the connector for each wire and while doing so, insert the stripped end of the wire. Upon release of the lever, the wire will be secured in the connector. CAUTION ! Be careful in depressing the lever so as not to break the lever. The polarity of the 16VAC power wiring does not matter, therefore it makes no difference which wire goes into which connector. At this point you can now connect the power to the transformer or wait until you have connected the sensors, which ever you prefer.

---

**It will be noted that on the panel assembly there are connectors marked "ALK". These connectors are NOT to be USED. The use of an Alkaline battery is NOT an option.**

---

***CONTINUE ON THE NEXT PAGE***

**OPTION  
SOLAR PANEL**

**Refer to FIGURE 10 below:**

Model Numbers shall be as; PRO-SH-SP or PRO-PH-SP. (SP designating the Solar Panel Option).

An option is for use of a Solar Panel, for the power supply, rather than the standard 120VAC/16VAC transformer. Mount the solar panel to the weather station tower using the mounting brackets furnished as part of the solar panel assembly. Mount the solar panel to the tower so it faces south (northern hemisphere). Position the solar panel as high off the ground as practical, ensuring it cannot interfere with air flow or sunlight around the sensors.

The solar panel should be oriented to receive maximum sun light exposure over the course of the year. It is also necessary that the solar panel have the proper "tilt". Suggested "tilt" angles (reference to the horizontal plane) are listed below.

<u>Site Latitude</u>	<u>Tilt Angle</u>
0 to 10 degrees	10 degrees
11 to 20 deg.	Latitude +5 degrees
21 to 45 deg.	Latitude +10 degrees

46 to 65 deg. Latitude +15 degrees

65 deg. 80 degrees

After determining the "tilt" angle, loosen the two (2) bolts that attach the solar panel to the mounting bracket. Adjust the angle of the solar panel, then tighten the bolts to secure it in the proper position. Secure the lead wire, coming from the solar panel, to the Tower mast using wire ties.

The solar panel cable shall be routed up and through the Heyco fitting on the back panel of the Enclosure and marked "power". Unscrew the cap of the Heyco fitting (on the back side of the enclosure) and push the plug out of the fitting. This plug can be discarded as it will not be used. Now feed the solar panel power cable through the Heyco fitting and connect it to the connectors of the Enclosure, marked "CHG". The wires can be attached to these connectors by "depressing" the lever on the connector for each wire and while doing so, insert the stripped end of the wire. Upon release of the lever,, the wire will be secured in the connector. CAUTION ! Be careful in depressing the lever so as not to break the lever. The polarity of the wires does not matter, therefore it makes no difference which wire goes into which connector. The solar panel installation should now be completed.

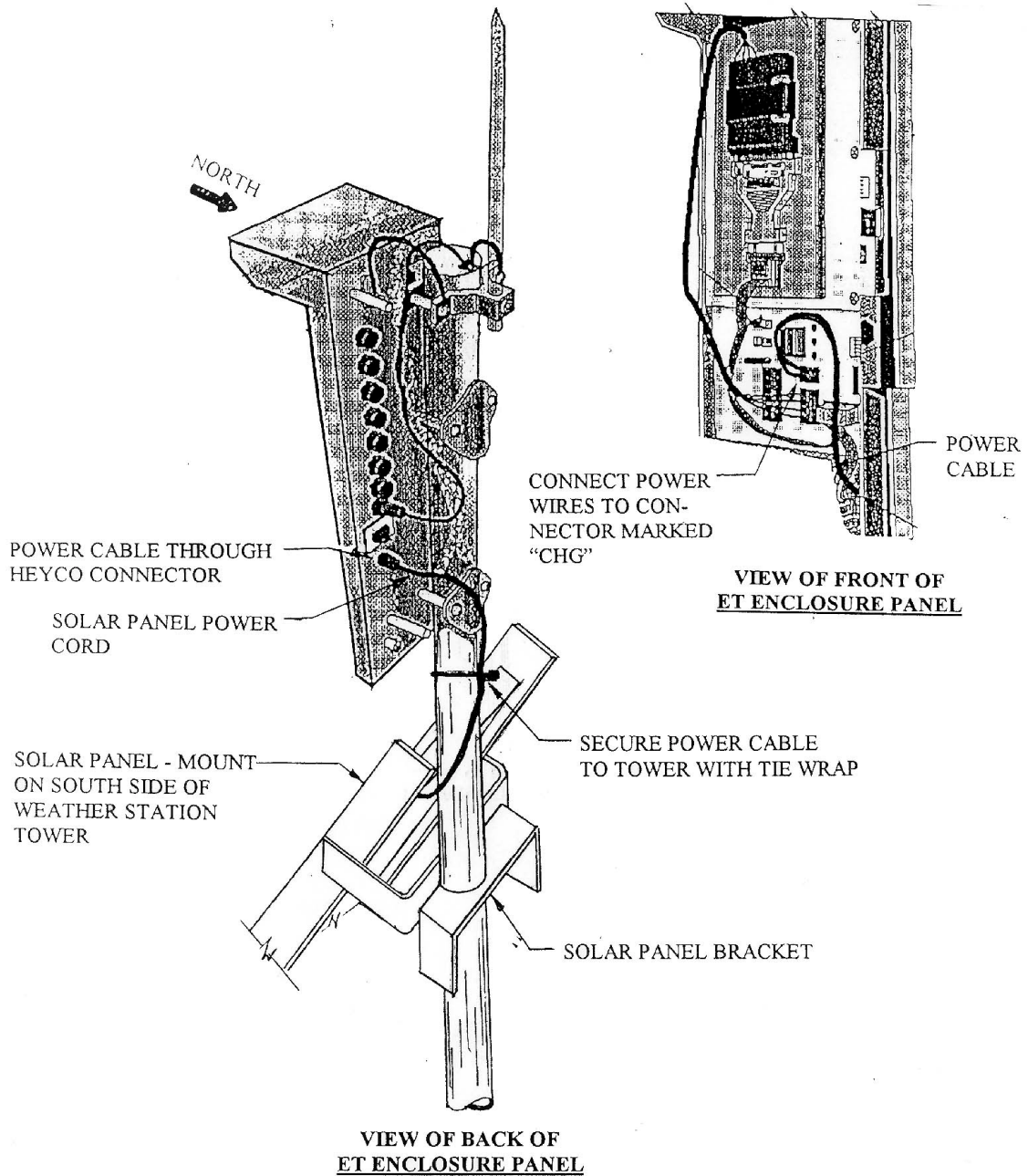

**FIGURE 10 - SOLAR PANEL INSTALLATION DETAIL**

**8.0 INSTALLATION OF INSTRUMENTATION**

## **GENERAL:**

The Model PRO weather station comes with the some of the sensing instruments, and sensor wiring to datalogger completely assembled as a unit on a cross-arm. The Solar Radiation Pyranometer - along with the leveling device are mounted on a bracket, which in turn is mounted on the cross-arm of the Enclosure. On this end of the cross-arm the "Tipping Rain Bucket" is also mounted at the factory. On the opposite end of the cross-arm is attached the mounting bracket, which has been factory installed, for the Wind speed and Wind direction sensing instruments. The Temperature and Relative Humidity sensors are on the end of their cable and only need installing into the radiation shield. The cables for each of these sensors are mounted in the cross-arm and terminated at the proper location of each sensor. The cables only need to be routed and plugged into the proper connectors on the back of the back panel of the ET Enclosure.

## **SUPPLIED COMPONENTS**

- (1) Sensor Cross-Arm
- (1) Met One 034A Wind Sensor
- (1) 034A Mounting Shaft
- (1) Radiation Shield

## **INSTALLATION OF CROSS-ARM TO ET ENCLOSURE:**

### **Refer to FIGURE 11 below:**

Remove the four (4) Phillips head screws from the bottom center of the cross-arm. With the Enclosure cover removed, place the cross-arm on top of the Enclosure. The cross-arm needs to be oriented along a due east to due west axis. If necessary adjust the Enclosure on the tower to properly orient the cross-arm. Also be sure that the opening in the middle and one side of the cross-arm, where the sensor cables exit, is to the back of the Enclosure so that the cables can enter the top of the cover that fits over the cable connectors on the back of the Enclosure. Line up the four threaded holes on the under side of the cross-arm (where you just removed the screws) with the four holes in the top of the Enclosure. Attach the cross-arm to the Enclosure by inserting the four (4) screws, from in side the enclosure up through the top and into the threaded holes of the cross-arm. Tighten the screws securely.

---

**REFER TO NEXT PAGE FOR FIGURE 11**

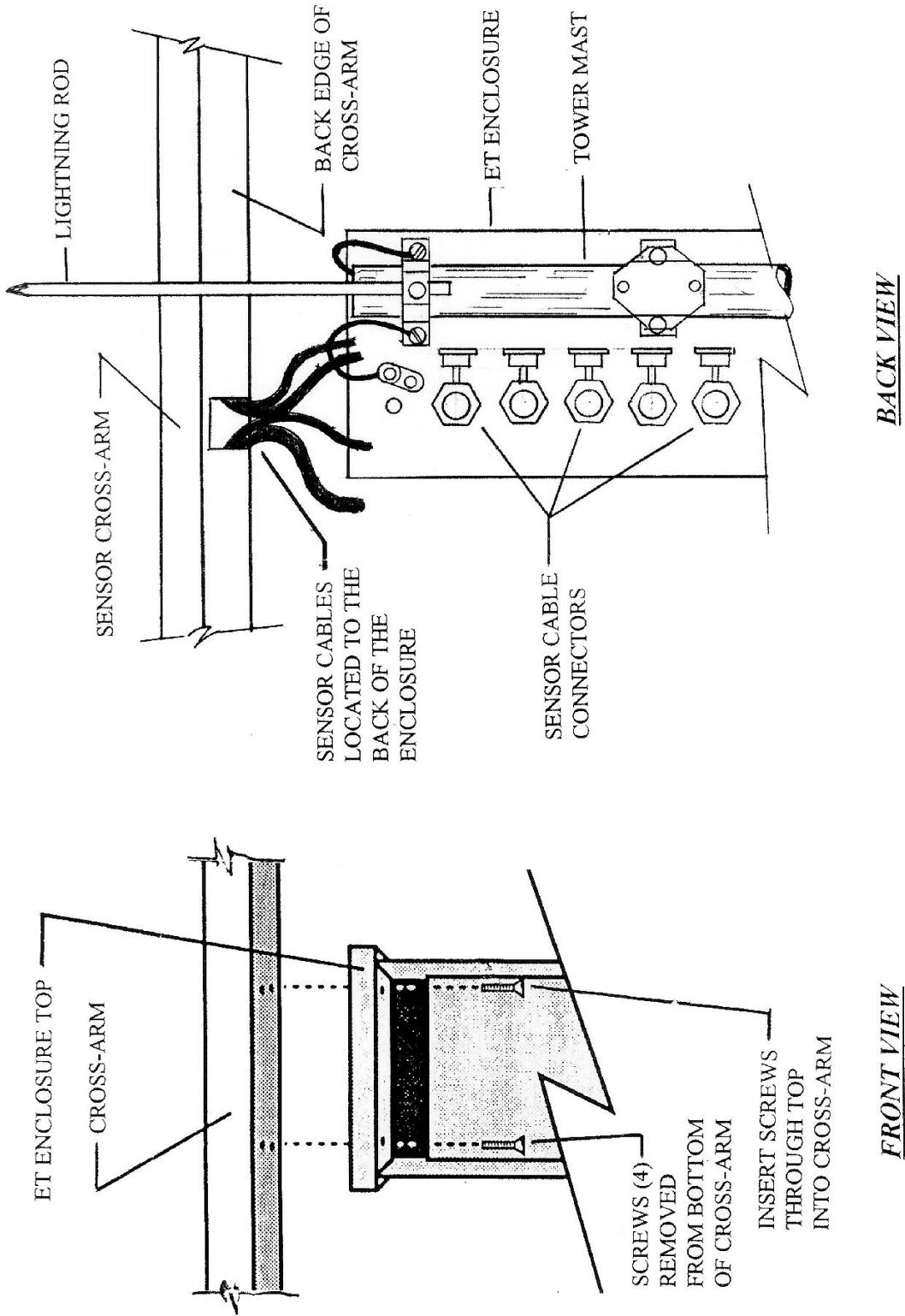

FIGURE 11 - CROSS-ARM MOUNTING

## **INSTALLATION OF 034A WIND SENSOR:**

### **Refer to FIGURE 12 below:**

With the Sensor Cross-Arm securely installed to the Enclosure you are ready to install the 034A Wind Sensor instrument. The wind vane is oriented after the datalogger has been programmed and the location of True North has been determined. Orientation is most easily done with two people, one to aim and adjust the sensor, while the other observes the wind direction displayed by CR10KD Keyboard Display or a laptop PC computer.

Remove the aligning screw from the base of the 034A wind sensor unit. Place the 034A wind sensor into the mounting shaft, that is clamped to the end of the sensor cross-arm by means of a U-Bolt clamp.

(The short, black mounting shaft, included with the 034A wind sensor will NOT be used).

Secure the 034A wind sensor in the mounting shaft, by aligning the threaded hole in the wind sensor with the hole in the side of the mounting shaft, and re-installing the aligning screw.

Next loosen the set screw in the top of the 034A wind sensor (the set screw opposite the one securing the wind direction point). Place the end of the wind vane into the hole. Properly orient the vane to be in a true vertical position and secure it by tightening the set screw.

Attach the wind sensor cable connector to the connector on the 034A wind sensor.

Without allowing the mounting shaft for the 034A wind sensor to "slip down" (it may be a good idea to mark the position of the U-Bolt on the shaft so that you can correctly position it should it "slip") slightly loosen the nuts of the "U-Bolt" clamp of the mounting shaft - just enough so you can rotate the mounting shaft but not allow the shaft to "slip down".

Establish a reference point on the horizon for True North.

Sighting down the instrument center line, aim the counter weight at True North. Display input location #8 for wind direction, using the \*6 Mode of the datalogger.

While holding the wind vane position, slowly rotate the sensor base/mounting shaft until the datalogger indicates 0 degrees. Securely tighten the clamp nuts.

---

**REFER TO NEXT PAGE FOR FIGURE 12**



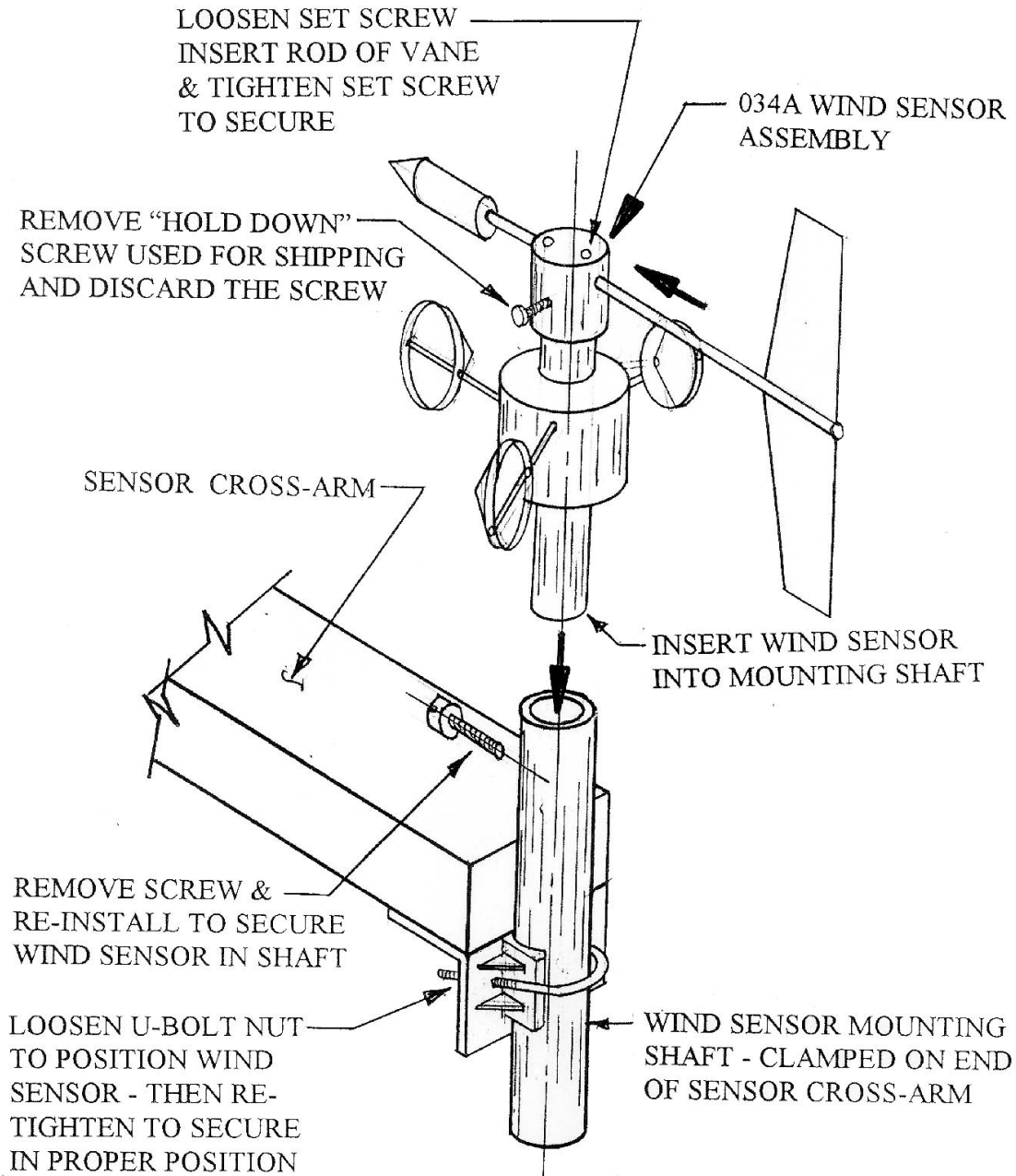

**FIGURE 12 - WIND SENSOR INSTALLATION DETAIL  
INSTALLATION OF RELATIVE  
HUMIDITY / TEMPERATURE  
SENSOR AND RADIATION  
SHIELD:**

**Refer to FIGURE 13 below:**

On the bottom of the Cross-Arm, on the end where the wind sensor has been installed, remove the two screws for the Relative Humidity/Temperature sensor Radiation Shield.

Un-tape the RH/Temperature sensor from the bottom of the Cross-Arm.

Remove the "yellow" protective plastic cap from the end of the sensor, by slipping it off the end of the sensor. This can be discarded as it will not be used.

Insert the RH/Temperature sensor into the end of the shaft of the Radiation Shield. Insert it to a depth where it is securely seated. Now secure the Radiation Shield to the bottom of the sensor Cross-Arm with the two (2) screws you have previously removed.

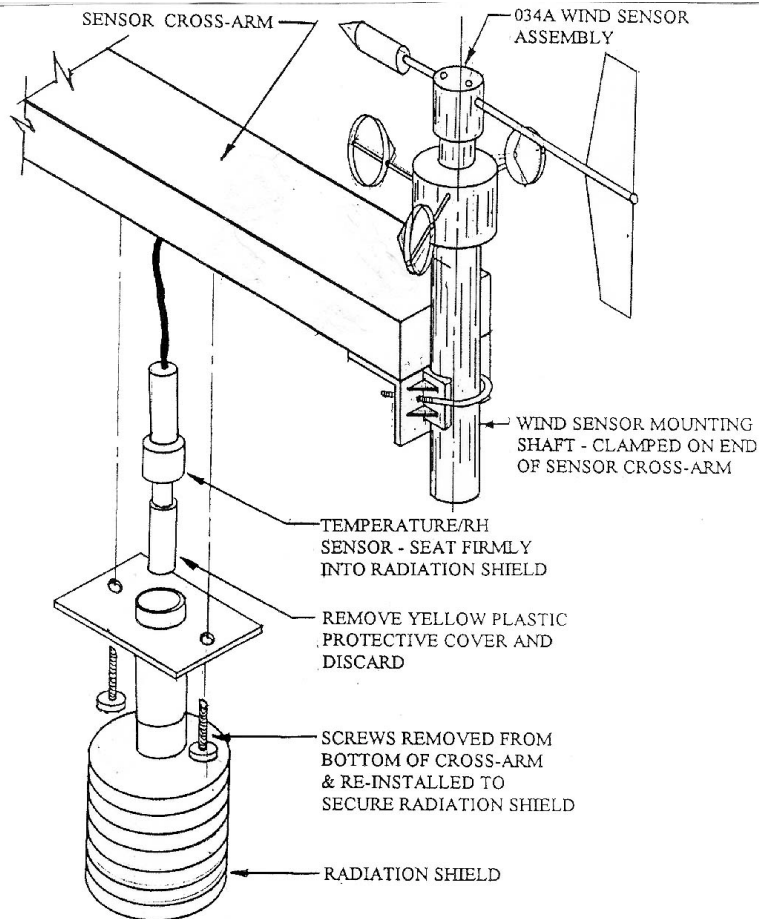

**FIGURE 13 - TEMPERATURE/RH SENSOR INSTALLATION DETAIL**

**Refer to FIGURE 14 below:**

**INSTALLATION OF SOLAR RADIATION PYRANOMETER:**

The Solar Radiation Pyranometer, (with the leveling device) is mounted, at the factory, on a mounting bracket at the opposite end of the cross-arm near the Tipping Rain Bucket gage. By using

the three (3) leveling screws - level the Pyranometer. After leveling - remove the "RED" protective cap from the Pyranometer.

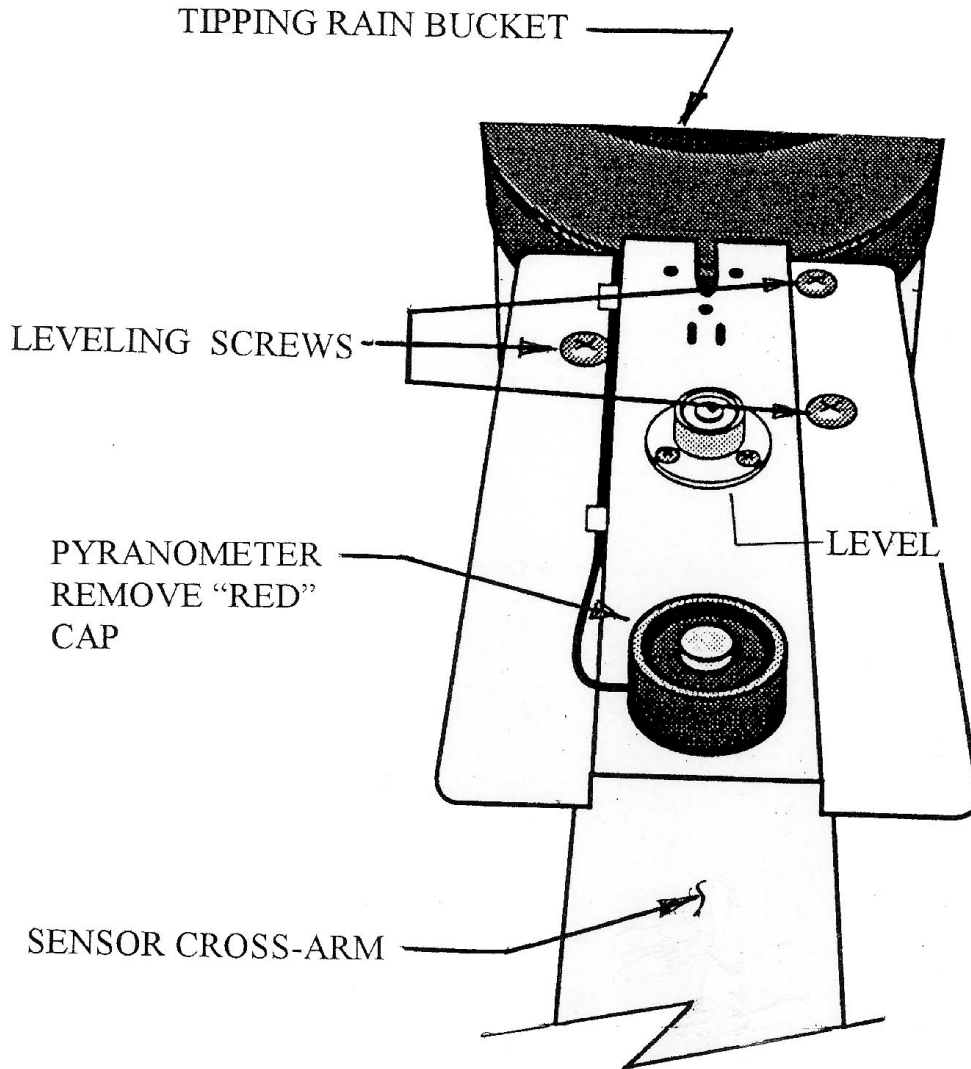

**FIGURE 14 - SOLAR RADIATION SENSOR INSTALLATION DETAIL  
SENSOR CABLE CONNECTIONS:**

**Refer to FIGURES 12 & 15:**

The Sensor Cables exit from the center back of the Cross-Arm. The cables need to be routed down the back of the Enclosure and plugged into the connectors on the back panel of the Enclosure as follows:

Temp/RH #10090 cable - connect to #1 connector [labeled "TEMP/RH"]

WD/WS (Wind Direction/Wind Speed) #10408 cable - connect to #2 connector [labeled "WS/WD"]

Solar Radiation #10105 cable - connect to #3 connector [labeled "SOLAR RADIATION"]

Making sure that all cables are properly enclosed behind the cover - replace the cable cover. Be sure that you do not pinch any of the cables between the cover and the back panel of the Enclosure

Rain #10094 cable - connect to #5 connector [labeled "RAIN (PRECIP)"]

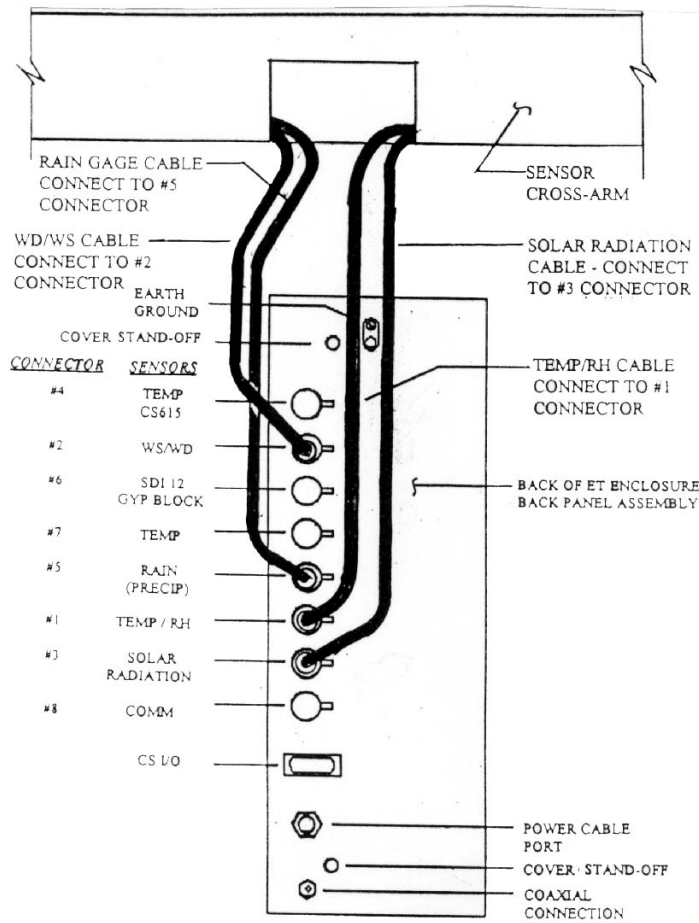

FIGURE 15 - SENSOR CABLE CONNECTIONS

**CONFIGURE SENSOR SWITCH SETTINGS:**

Refer to FIGURE 16 below:

The Sensor Switches are located on the ET Enclosure panel just below the

modem and to the right of the the "Heat Sink" located to the right of the battery connectors. These switches or pots need to be set as indicated in FIGURE 16 below.

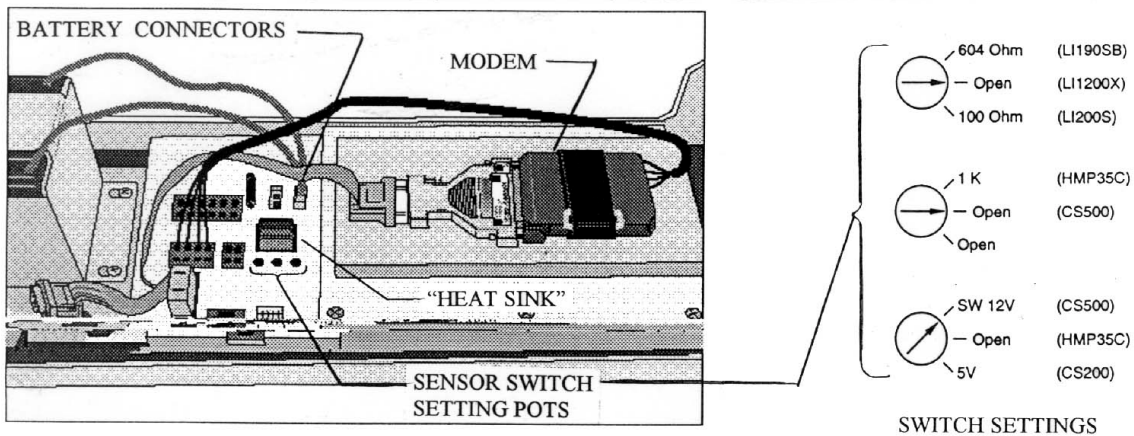

**FIGURE 16 - SENSOR SWITCH SETTINGS**

**UPGRADING A "JR" MODEL WEATHER STATION TO A "PRO" MODEL:**

Refer to FIGURE 17 below:

By means of the "UPGRADE KIT" a Model "JR" Rain Bird weather station can be upgraded to a Model "PRO" weather station.

On the top of the Enclosure of the existing model "JR" weather station - remove the three (3) leveling screws and springs from the mounting bracket for the Temperature/Relative Humidity and Solar Radiation sensors.

Remove the white Temperature/Relative Humidity sensor from the bracket by removing the three screws under the bracket and securing it to the bracket. This sensor will NOT be used with the new upgrade kit.

Reverse the orientation of the mounting bracket and place it on the upgrade

cross-arm, on the support brackets on the cross-arm near the tipping bucket rain gage. Thread the three (3) leveling screws into the threaded holes in the support brackets. Be sure that the spring, for each screw, is between the mounting bracket and the support bracket. Turn each screw two (2) or three (3) turns into the threaded holes.

Install the sensor cross-arm to the top of the Enclosure as previously described. All other sensors, including the 034A Wind Sensor, the Radiation Shield, cables, etc. shall be installed as previously described in this section.

All cables shall be connected to the connectors on the back panel of the Enclosure - as previously described and as shown in FIGURE 15.

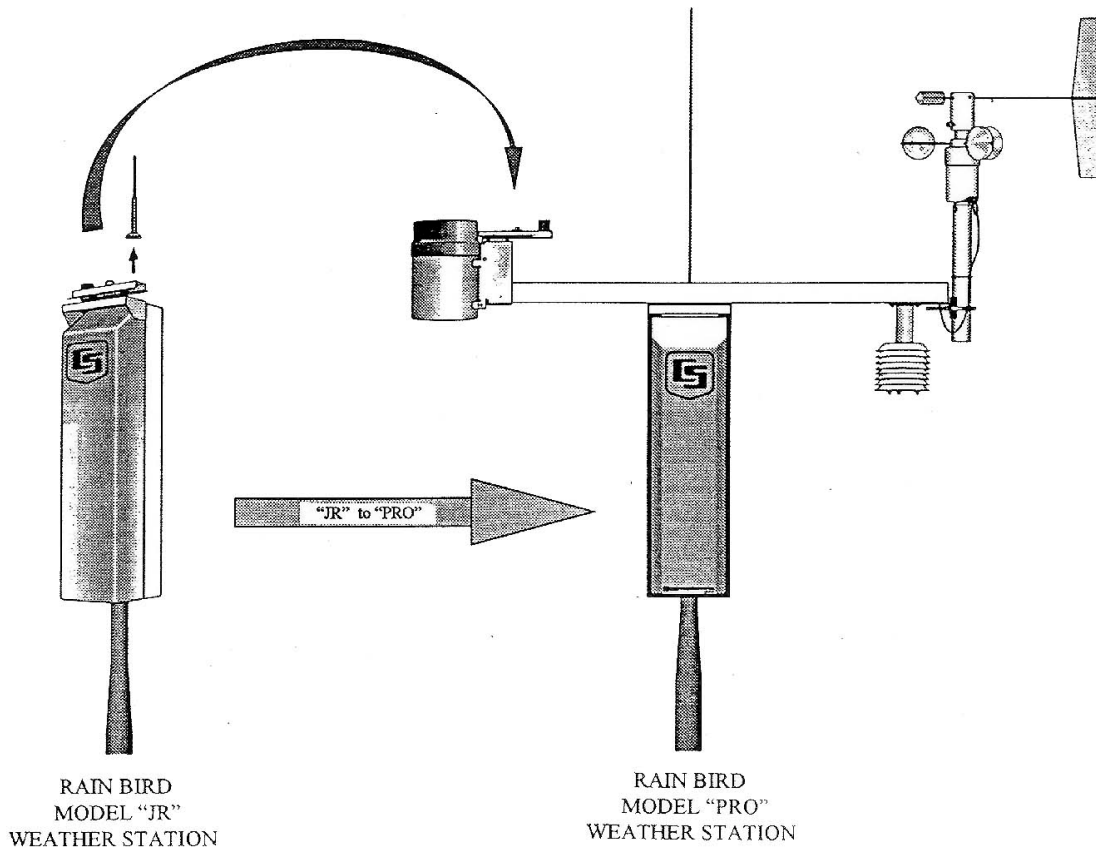

FIGURE 17 - UPGRADING A "JR" TO A "PRO" WEATHER STATION



**SENSOR VERIFICATION AND  
CLOCK SET:**

Check the measurements of all sensors after the datalogger is programmed. Display measurements using the \*6 Mode with the ML10KD datalogger support software.

***Input***

<b><u>Loc.</u></b>	<b><u>Parameter</u></b>	<b><u>Normal Range</u></b>
1	Battery (Volt)	12.9 to 14.2 Volts
2	Air Temp. C degrees	-40 to +50
3	Humidity	0% to 100%
4	Wind Run	0 to 800 Kms/day
5	Solar (Langleys)	0 to 0.07 cal/cm2
6	Rain Fall	0 to 0.02 inches
7	Wind Direction	0 to 359 degrees
8	Air Temp.	-40 to +122 degrees F
9	Humidity	0% to 100%
10	Wind Speed	0 to 110 mph
11	Solar (Langleys)	0 to 0.07 Cal/cm2
12	Rain Fall	0 to 0.02 inches
13	Encl. Humidity	10 to 30% when sealed for several hours
14	Encl. Internal Temperature	Close to Air Temperature
15	Program Signature	Depends on Program Version

**SHORT HAUL MODEM  
INSTALLATION**

**Refer to FIGURE 18 below: (PRO-SH)**

The Short Haul Modem, at the weather station, is normally installed at the factory in the ET Enclosure. The Short Haul Modems enable communication between the datalogger and the central computer over two (2) twisted pairs of wires. The maximum distance between modems is determined by the baud rate and the wire gauge. At 9600 baud, the approximate range is 4.0 miles. DCE/DTE switches on the modems must be set to DCE.

**INSTALLATION:**

For installation of the Short Haul RAD Modem inside the Enclosure, the following components are provided in the Short Haul modem kit:

- SC932C Interface w/ribbon cable
- RAD Modem
- RAD/SC932C Mounting Bracket
- Velcro Mounting Strap w/Buckle
- Mounting Screws
- 12 inch 4-wire Patch Cable

Partially install three (3) of the furnished screws in the holes on the left side of the Enclosure housing for the datalogger.

Hold the Modem mounting bracket in the position it will be in the Enclosure. Thread the Velcro mounting strap through the two outer slots of the lower set of slots in the modem mounting bracket. Thread from the top down on the far left slot first. The side of the strap with Velcro should be facing



"down" toward the datalogger housing. Then carry the strap across the back of the bracket and thread it to the front of the bracket through the far right slot of the lower set of slots.

Slide the bracket flange, with the three screw slots, under the heads of the three (3) mounting screws you have partially installed in the holes on the left side of the datalogger housing. With the bracket fully seated tighten the three (3) screws to secure the mounting bracket to the datalogger housing.

Connect the SC932C Interface to the RAD Modem. Position this assembly on the mounting bracket with the SC932C Interface pointing "down". Strap the SC932C Interface unit securely

to the mounting bracket, using the Velcro strap.

Connect the SC932C 9-pin port to the internal Enclosure 9-pin port (located just below the Phone Modem port) using the blue ribbon cable provided.

Wire the RAD modem to the Enclosure with the 12 inch 4-wire patch cord provided. Black (-XMT) wire to -XMT connections at the RAD modem and at the connector on the Enclosure. The RED (+XMT) wire to the +XMT connections, the White (-RCV) wire to the -RCV connections and the Green (+RCV) wire to the +RCV connections at the RAD modem and at the terminal blocks: RED to +RCV, Black to -RCV, Green to +XMT, White to -XMT.

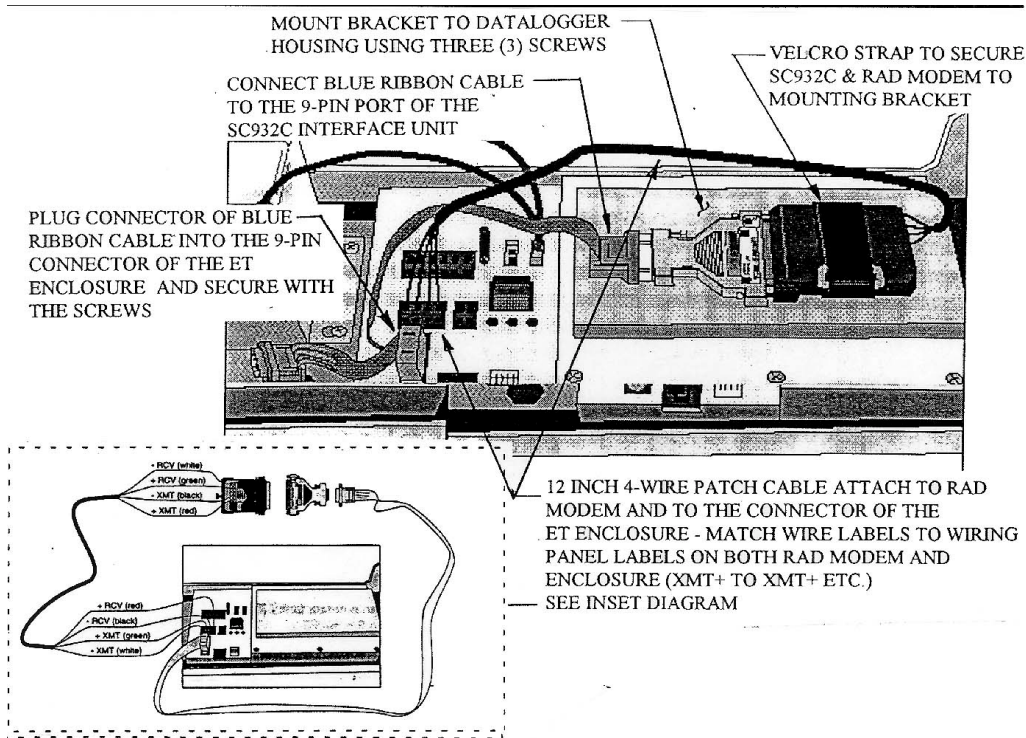

FIGURE 18 - SH MODEM INSTALLATION IN ET ENCLOSURE INSTALLATION

TELEPHONE MODEM



**Refer to FIGURE 19 below:**  
**(PRO-PH)**

The Telephone Modem, at the weather station, is normally installed at the factory in the Enclosure. The telephone modems enable communication between the datalogger and a Hayes compatible modem at the central computer over a dedicated telephone line. Phone line surge protection is built into the Enclosure.

**INSTALLATION**

For installation of the phone modem inside the Enclosure, the following components are provided in the modem kit:

- COM200 or COM 300 Modem
- 12 inch RJ-11 Patch Cord
- Modem Mounting Bracket
- Mounting Screws
- 12 inch #14 AWG Ground Wire
- 4 Screws and Nuts

Partially install three (3) of the furnished screws in the holes on the left side of the Enclosure housing for the datalogger.

Attach the phone modem to the mounting bracket, using the four screws and nuts.

Taking the phone modem and bracket assembly - install the two keyhole slots in the bracket over the top two (2) screws that you have previously installed in the datalogger housing. Be sure the open slot in the bracket is in line with the lower screw. Seat the modem properly and tighten the screws to secure the modem to the datalogger. Connect the 9-pin connector of the Blue Ribbon Cable to the phone modem 9-pin port. Connect the other end of the ribbon cable to the 9-pin port (marked "CS I/O") on the Enclosure. Secure it with the two screws on the connector.

Connect the modem RJ-11 Patch Cord to the RJ-11 jack on the phone modem (located to the right of the 9-pin port). Connect the other end of the RJ-11 Patch Cord to the RJ-11 jack on the Enclosure, marked "phone modem".

Connect one end of the 12 inch #14 AWG ground wire to the terminal, marked "GND" and located on the right side of the phone modem. Connect the other end of this ground wire to the connector on the Enclosure that is marked "GND".

---

The installation of the phone modem is now completed.

**REFER TO NEXT PAGE FOR FIGURE 19**

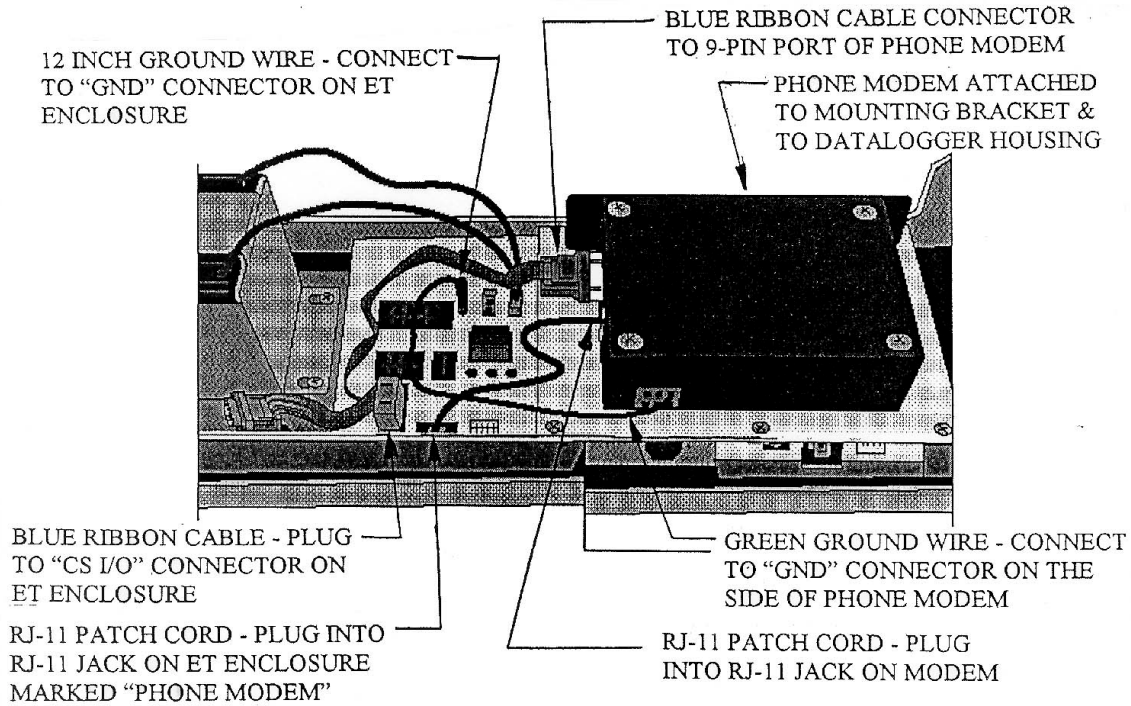

**FIGURE 19 - TELEPHONE MODEM INSTALLATION IN ET ENCLOSURE**

## 9.0 SEALING & DESICCATING THE ENCLOSURE:

The Enclosure is supplied with a desiccant pack. The desiccant maintains a low humidity in the enclosure to minimize the chance of condensation on the instrumentation. Desiccant should be changed when the internal Enclosure humidity sensor measures 30% or higher. Install the desiccant as shown in FIGURE 21 below.

Keep unused desiccant tightly sealed in an airtight container.

Take the desiccant pack out of its sealed plastic bag. Place it under the desiccant strap just before leaving the station.

Be sure to close the enclosure hasp securely. A padlock may be used on the latch for extra security.

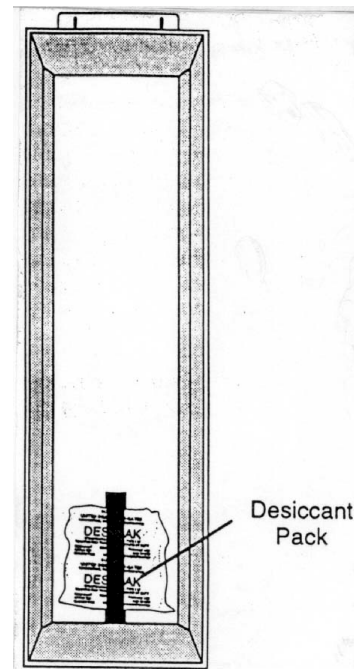

**FIGURE 20 - DESSICANT PACK INSTALLATION**

## 10.0 INSTALLATION AT CENTRAL COMPUTER

**MODEL PRO - SH ~ Direct Connected:**

**Refer to FIGURE 22 below:**

### **SUPPLIED COMPONENTS**

- (1) SMR-5A RAD Modem
- (1) 5 Foot 4-Wire Patch Cord
- (1) 25 Foot #10 AWG Ground Wire
- (1) Surge Protection Box

### **INSTALLATION**

Attach the 5 foot 4-wire patch cord to the SRM-5A RAD modem unit, which is furnished as part of the weather station. Connect the GREEN (XMT+) wire to the "XMT+" terminal of the RAD modem. Connect the WHITE (XMT-) wire to the "XMT-" terminal, the RED (RCV+) wire to the "RCV+" terminal and the BLACK (RCV-) wire to the "RCV-" terminal.

Connect the SRM-5A RAD modem directly to the serial port of the computer or use a 9-pin to 25-pin adapter if required.

Mount the Surge Arrestor Box, which is furnished as part of the weather station, in a suitable location near the computer (within less than 5 feet, as the patch cord is only 5 feet long).

Take the other end of the Patch Cord, that you have previously connected to the modem, and connect the GREEN

(XMT+) wire to the upper left connector in the Surge Arrestor Box. Connect the WHITE (XMT-) wire to the upper right connector, connect the RED (RCV+) wire to the lower right connector and the BLACK (RCV-) wire to the lower left connector of the surge arrestor box.

Just outside the building of the central computer location, install an 18" x 24" rectangular valve box with cover over one ground rod of a 3-rod grounding grid. (You may use the 3-rod grounding grid for the central Interface unit, etc. if located nearby).

Furnish and install and MGP-1 grounding plate assembly on the ground rod in the valve box. Furnish and install in the MGP-1 grounding plate assembly two (2) MSP-1 Pipe Surge Arrestors. Be sure to have the end marked "EQUIP" toward the central equipment and the "LINE" end toward the weather station. Ground both ends of each of the MSP-1 Surge Arrestors to a screw on the MGP-1 grounding plate assembly.

Using a piece of Belden #9883 direct burial cable (of sufficient length to reach from the Surge Arrestor Box to the Valve box) take the Green and Black twisted pair of wires and connect the GREEN (XMT+) wire to the upper left terminal in the Surge Arrestor Box. Connect the BLACK (XMT-) wire to the upper right terminal in the Surge Arrestor Box. Take the Red and Black twisted pair of wires and connect the RED (RCV+) wire to the lower right terminal of the Surge Arrestor Box. Connect the BLACK (RCV-) wire to the

lower left terminal of the Surge Arrestor Box. Leave the third pair of twisted wires, consisting of a Black and White wire disconnected and for a spare pair. The copper drain wire shall also be left disconnected.

Route the Belden cable, out of the building, under ground and out to the valve box. Taking the Green and Black twisted pair of wires, connect the GREEN (XMT+) wire to the RED wire, on the end marked "EQUIP", to one of the MSP-1 Pipe Surge Arrestor that you have installed in the MGP-1 Grounding Plate Assembly. The BLACK (XMT-) wire shall be connected to the BLACK wire, on the end marked "EQUIP", of this MSP-1 Surge Arrestor.

Next take the Red and Black twisted pair of wires of the Belden cable and connect the RED (RCV+) wire to the RED wire, on the end marked "EQUIP", of the second MSP-1 pipe surge arrestor. Connect the BLACK (RCV-) wire to the BLACK wire, on the end marked "EQUIP", of this second MSP-1 pipe surge arrestor.

The third twisted pair, consisting of a Black and White wire pair, shall be left as a spare and un-connected. The copper drain wire shall also be left disconnected.

A Belden #9883 Cable, consisting of three twisted pair of wires, a copper drain wire and an aluminum shield with an outer insulation for direct burial, shall be run underground form the central

location valve box out to the weather station location. At the valve box, at the central location, take the Green and Black pair of wires and connect the GREEN (XMT+) wire to the RED wire, coming from the end marked "LINE", of the first MSP-1 pipe surge arrestor. Connect the BLACK (XMT-) wire from this pair, to the BLACK wire, coming from the end marked "LINE", of the first MSP-1 pipe surge arrestor.

Take the Red and Black twisted pair of wires, of the Belden cable and connect the RED (RCV+) wire from this pair, to the RED wire coming from the end marked "LINE", of the second MSP-1 pipe surge arrestor. Connect the BLACK (RCV-) wire from this pair, to the BLACK wire coming from the end marked "LINE", of the second MSP-1 pipe surge arrestor.

The third twisted pair, consisting of a Black and White wire pair, shall be left as a spare and un-connected. The copper drain wire shall also be left disconnected.

To the center ground terminal in the Surge Arrestor Box - connect one end of the #10 gauge bare copper ground wire. Route this wire out the bottom of the box, underground out to the valve box and connect it to the ground rod using a brass clamp. Keep this ground wire as short and as straight as possible with NO sharp bends or "kinks".

For connections and wiring at the Weather Station, refer to Section 5.0 of this manual.

---

**REFER TO NEXT PAGE FOR FIGURE 21**

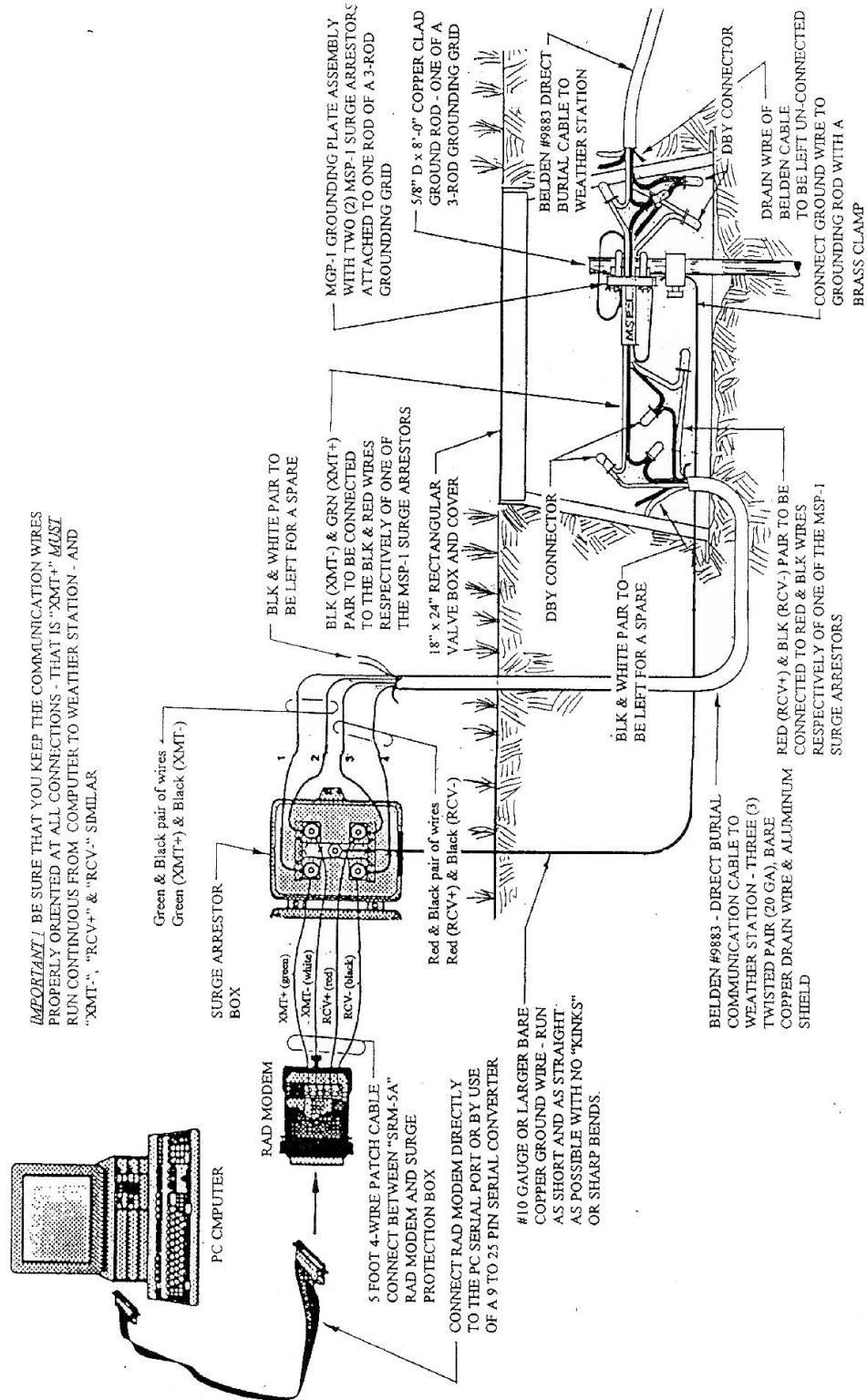

**FIGURE 21 - INSTALLATION AT CENTRAL COMPUTER FOR DIRECT CONNECTED WEATHER STATION**

**MODEL JR - PH ~ Phone Connected:**

**Refer to FIGURE 22 below:**

**SUPPLIED COMPONENTS**

- (1) Telephone Patch Cable
- (2) 25 Foot #10 Gauge Ground Wire
- (1) Surge Arrestor Box

**INSTALLATION**

Furnish and install a Hayes Compatible - 9600 baud modem. Using the ribbon cable that comes with the modem connect one end to the RS232C cable connector on the Modem. Connect the other end of this ribbon cable to the serial port of the computer. Use a 9-pin to 25-pin adapter if required.

Plug the "Plug-In" type transformer, that has been supplied with the modem, in to an 120 VAC electrical outlet.

Surge protection, for protection against surges coming in on the telephone lines, is built into the Weather Station. In addition the telephone company also furnishes surge protection on their lines. Therefore no additional surge protection is required upon installation of the Weather Station.

**STANDARD INSTALLATION  
METHOD**

Taking the telephone patch cable, connect the WHITE ("TIP") wire, of this cable, to the "Tip" line of a piece of underground telephone cable. Connect the BLACK ("Ring") wire, of this patch cable, to the "Ring" line of this piece of underground telephone cable.

Route this piece of direct burial telephone cable, out of the building, under ground and out to the valve box, located just outside the building. In the valve box connect the "TIP" wire (white) to the WHITE "TIP" wire of the direct burial underground telephone cable installed by the telephone company. Connect the "RING" wire (black) to the BLACK "RING" wire of the direct burial underground telephone cable installed by the telephone company.

**REFER TO NEXT PAGE FOR  
FIGURE 22**

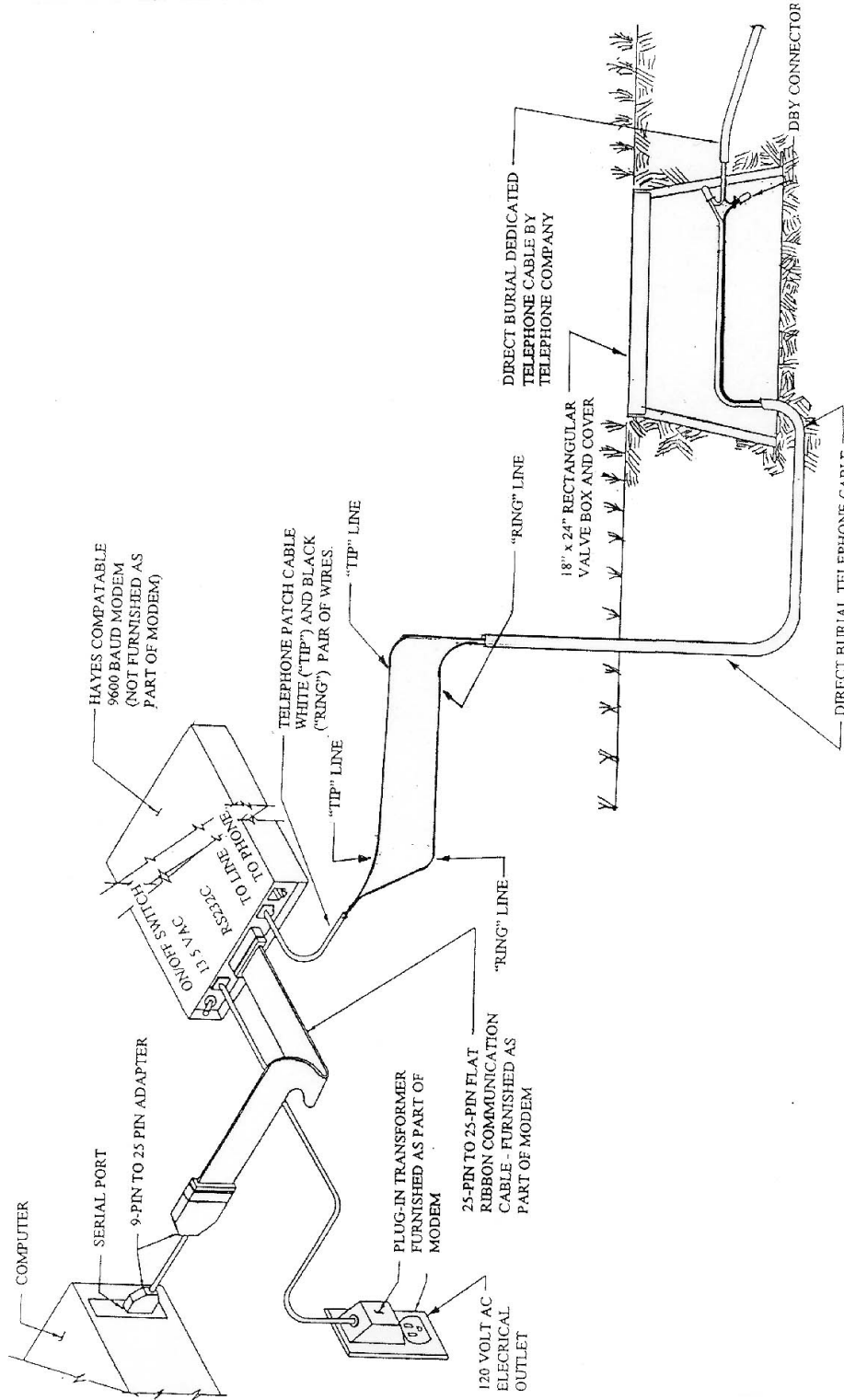

**FIGURE 22 - INSTALLATION AT CENTRAL COMPUTER FOR TELEPHONE CONNECTED WEATHER STATION**



## 11.0 MAINTENANCE & TROUBLESHOOTING

### **GENERAL MAINTENANCE:**

Proper maintenance of weather station components is essential to obtain accurate data. Equipment must be in good operating condition, which requires a program of regular inspection and maintenance. Routine and simple maintenance can be accomplished by the person in charge of the weather station. More difficult maintenance such as sensor calibration, sensor performance testing (i.e., bearing torque), and sensor component replacement, generally requires a skilled technician, or that the instrument be sent to Campbell Scientific for repair or updating. Contact your local Rain Bird distributor for instructions.

A station log should be maintained for each weather station that includes serial numbers, dates that the site was visited and maintenance that was performed.

### **INSTRUMENTATION MAINTENANCE:**

The instrumentation requires a minimum of routine maintenance. A few preventative maintenance steps will optimize battery life and decrease the chances of datalogger failure.

### **BATTERIES:**

#### **RECHARGEABLE**

Rechargeable power supplies should be connected to an AC transformer or unregulated solar panel at all times.

Be aware of battery voltage that consistently decreases over time, which indicates a failure in the charging circuitry.

### **DESICCANT:**

Enclosure humidity is monitored in the Enclosure. Change the desiccant packs when the enclosure RH exceeds 35%. The RH chip should be changed every 5 to 8 years.

### **SENSOR MAINTENANCE:**

Sen0sor maintenance should be performed at regular intervals, depending on the desired accuracy and the conditions of use. A suggested maintenance schedule is outlined below.

#### ***1 Week -***

- Visually inspect the station and all sensors. Look for any damage and debris that may disturb sensor readings.
- Check the pyranometer for level and contamination. Gently clean with a soft bristle brush, if needed.
- Check and Clean the Tipping Bucket Rain Gage, especially the bucket screen and the small funnel outlet.

To check accuracy of the rain gage - 16 ounces of fluid is equal to 1" of rainfall. Fluid must be poured into the gage **VERY SLOWLY** to get an accurate bucket tipping count.



**1 Month -**

- Check the temperature/relative humidity sensor for contamination.

**6 Months -**

- Clean the temperature/relative humidity sensor.
- Check battery by disconnecting the AC Power and allow it to stabilize for at least 2 hours. Then check the voltage. Reconnect battery to AC Power.

**1 Year -**

- Replace the RH chip if necessary.

**2 Years -**

- Calibrate the Pyranometer (some suggest yearly).
- Replace RH chip in Air Temp/RH Sensor.
- Calibrate the Tipping Bucket Rain Gage. To check accuracy of the rain gage - 16 ounces of fluid is equal to 1" of rainfall. Fluid must be poured into the gage **VERY SLOWLY** to get an accurate bucket tipping count.

**4 - 5 Years -**

- Replace sensor cables as requires.

**General Maintenance**

- An occasional cleaning of the glass on the solar panel will improve its efficiency.
- Check sensor leads and cables for cracking, deterioration, proper routing and strain relief.
- Check the tower for structural damage, proper alignment and for level/plumb.

## SENSOR MAINTENANCE

### **RAIN GAUGE**

Inspect and clean every two to three months - removing leaves, debris, etc. In extreme environmental conditions it may be necessary to do this on a MONTHLY basis.

- Check that the tipping mechanism moves freely and that it registers **0.01 inches per tip**.
- Check and Re-Level the Rain Bucket, if necessary.
- Calibrate the Rain Gage every 2 years.

#### *Calibrating the Rain Bucket:*

- Secure a metal can that will hold at least one quart of water.
- Punch a **VERY SMALL HOLE** in the bottom of the can.
- Place the can in the top of the funnel, of the Rain Bucket, and pour 16 fluid ounces (1 pint) of water into the can.
- If it takes **LESS** than 45 minutes for this water to run out, the hole in the can is **TOO LARGE**.
- One hundred (100) tips plus or minus three tips should occur and register from 0.97 inches to 1.03 inches. (0.01 inches per each tip).

Adjusting screws are located on the bottom of the Rain Bucket, adjacent to

the large center drain hole. Adjust both screws the same number of turns or partial turns. Rotation clockwise increases the number of tips per 16 ounces of water, counter clockwise rotation decreases the number of tips per 16 ounces of water. ***One half turn*** of both screws causes a **2% to 3% change**.

- Check and Re-Level the Rain Bucket lid.

Factory Calibration is available through your Rain Bird Distributor.

#### ***Suggestions:***

Devices for dripping water are available through a chemistry equipment supply house.

In order to see the 100 tips, configure a FAKE weather station within the weather software, to use for this testing. Drip the water and then do an upload using the new test configuration to see the number of tips (0.01 inches = 1 tip).

**CAUTION !** Be sure to ***disable*** any ***Automatic Uploads***, since the 100 tips will contaminate the every day weather data.

After the calibration is complete, reset the datalogger by removing the power and the battery connections in the Enclosure. ***Contact Campbell Scientific for further instructions.*** You will have to reset the time of day and year in the datalogger by up loading one day of data (#6 from the Weather Main Menu). The 7 days of data that are stored in the datalogger will be lost when you disconnect the power, so be sure to have done an upload before you begin the calibration process.

**SOLAR SENSOR**

- Inspect and clean the Solar Sensor (Pyranometer) every two (2) to three (3) months. It is best cleaned with a blast of clean, dry air or with a soft bristle, camel hair brush. *Be careful NOT to scratch the surface of the sensor. DO NOT use Windex, soap or any other cleaning agent as it may scratch or more likely leave a film on the surface, which will affect its accuracy.*
- In EXTREME environmental conditions it may be necessary to clean the Solar Radiation Sensor (Pyranometer) on a monthly basis.
- Be sure the DRAIN hole in the side of the sensor housing near the top, is OPEN and free of debris.
- Re-Calibration of the Solar Radiation Sensor (Pyranometer) should be done every two (2) years. Return the sensor, through your Rain Bird Distributor, for calibration.

**WIND SENSOR**

- Inspect bearings and operation of the Wind Sensor (wind speed and wind direction) on a regular basis, at least once a year. They should move freely and react to a wind speed of 2 to 3 mph.

The bearings have a life expectancy of 3 to 5 years, except in very high wind

areas, where their life may only be 1 year.

- The bearings can only be replaced by the factory and therefore need to be returned to the factory through your local Rain Bird Distributor.

*Checking the bearings of the 034A Wind Sensor.*

- Remove the Wind Sensor from the Weather Station cross-arm, by removing the set screw that is securing the sensor in the mounting shaft and raising the sensor up and out of the mounting shaft.
- Hold the Wind Sensor in a horizontal position (with one of the wind speed cups "down" toward the ground).
- On one of the cups hang an ordinary paper clip (0.5 gm weight) on the outer edge of one of the cups.
- Position this cup in the "up" position and release. The cup should rotate downward. Failure to rotate indicates the bearings need replacement.

**RELATIVE HUMIDITY SENSOR**

- The life of the RH chip is dependent upon air quality in your area. As a *General Rule* the RH chip should be replaced **EVERY 2 YEARS**, if necessary.
- In extreme environmental conditions, the RH chip may need to be replaced every year.

- The best time to change the chip is at the beginning of the most critical time for watering (spring and fall in the desert areas).
- Clean the screen, on the tip of the RH chip enclosure, every six (6) months more often, if required. If the screen gets dirty quickly, this will reflect how often the chip will need to be replaced.

### TEMPERATURE SENSOR

- Inspect and clean, at least every 2 to 3 months and more often in extreme environmental conditions.  
**CAUTION**  
Be careful of the thermister, as it is very delicate.
- Carefully clean insects and debris from the temperature probe.
- The temperature probe can NOT be calibrated, so if the readings are poor the complete probe must be replaced.
- After several years the temperature/RH sensor may become corroded and should be replaced.

**NOTE !** Water will affect the temperature readings, so be sure no direct water is hitting the weather station from sprinklers in the area.

### SEAL OF ET ENCLOSURE

The seal on the panel assembly of the Enclosure forms the seal between the Enclosure cover and the Enclosure back panel.

- This seal should be inspected on a regular basis, looking for cracks, hardening of the foam rubber and/or loosening from the back panel assembly.
- Any time the Enclosure is opened, upon closing it the desiccant pack should be replaced with a new desiccant pack.
- At least once a year the desiccant pack should be replaced with a new pack.
- The Enclosure internal moisture should be monitored. The desiccant pack maintains a low humidity in the enclosure and minimizes the chance of condensation on the datalogger and other electronic components.
- The desiccant pack should be changed when the internal Enclosure humidity sensor measures 35% or higher.
- If the moisture level gets too high the Enclosure should be opened and dried out. The desiccant pack needs to be replaced with a new pack.

- All parts should be dried with a clean, dry cloth and components inspected for corrosion.
- When replacing the cover on the Enclosure, place the cover top into the top of the Enclosure and be sure the cover is properly engaging in the tabs at the top of the Enclosure. Gently close the cover and secure it with the latch at the bottom. Be sure the latch hasp is securely latched, as keeping out moisture, is dependent upon a tight seal between the Enclosure back panel and the cover, provided by the molded rubber seal on the Enclosure back panel.
- The 16 VAC power or the solar panel power should be connected to the weather station at all other times.

### SENSOR TESTING

At least once a year, or whenever sensor failure is suspected, the sensors listed below should be checked with a volt/ohm meter for ohm resistance.

- Wind Sensor - Wind Speed (Anemometer) sensor
- Wind Sensor - Wind Direction Vane Sensor.
- Rain Gage Tipping Bucket
- Solar Radiation Sensor - Pyranometer.

All sensors that are to be checked, *EXCEPT the Rain Gage*, should have a measurable resistance. **INFINITE** resistance indicates an **OPEN circuit**. Any sensor with an open circuit needs to be repaired or replaced.

### BATTERY CHECK

- At least TWICE (2 times) a year the AC power wires to the charger should be disconnected to allow the station to operate off the batteries without the charger in operation.
- Check the battery under these conditions to get an accurate actual battery voltage level.
- Allow 2 hours, after the battery AC recharge power has been disconnected, for the battery to dissipate high voltage level before checking the voltage.

**CAUTION !** Be sure to RE-CONNECT the battery charger and/or power wires to the weather station after checking the battery voltage.

### WIND SPEED SENSOR

**Refer to schematic wiring diagram -  
located in the Appendix - FIGURE 29**

- Measure the resistance from P1 to G (pins 3 to 5) of the Wind Speed Sensor. Slowly turn the wind speed cup. The resistance should vary from infinite to less than 1 OHM as the reed switch closes in the anemometer.

**WIND DIRECTION**

**Refer to schematic wiring diagram -  
located in the Appendix - FIGURE 29**

- The Wind Direction sensor varies in its resistance as the vane turns. With the OHM meter connected to E2 and 2H (pins #1 & #2) the resistance should vary from 11K OHMS to 21K OHMS.
- If infinite resistance is measured, then the wiper in the potentiometer is most likely damaged and the sensor needs to be repaired.
- With the OHM meter connected to 2H & AG (pins #2 & #4) the resistance should vary from 1K to 11K OHMS with change in wind direction. If infinite resistance is measured then the potentiometer is bad and should be replaced.

**SOLAR RADIATION SENSOR  
PYRANOMETER**

**Refer to schematic wiring diagram -**

**located in the Appendix - FIGURE 30**

- The Solar Radiation Sensor (Pyranometer) should measure between 40 OHMS and 90.2 OHMS, when checked with an Ohm meter between 3H & 3L (pins #1 & #2).
- Set meter for lowest DC millivolts (a very sensitive meter is required) and measure from 3H to 3L (pins #1 & #2). The small voltage should vary with variation in light intensity. Place your hand over the sensor - should read 0 VDC.

**TIPPING BUCKET RAIN GAGE**

**Refer to schematic wiring diagram -  
located in the Appendix - FIGURE 31**

- The Rain Gage has a reed switch that closes as the tipping bucket mechanism "tips". Connect the OHM meter across P2 & G (pins #3 & #5) and should read infinite OHMS. When bucket mechanism is "tipped" - should then get less than 1 OHM.
- If the bucket tipping mechanism is working correctly you should read +5 Volts DC with the meter set at DC volts and connected across the reed switch, while sensor is plugged into the Weather Station. When the bucket is "tipped" the reed switch closes and you should have 0VDC. There is

continuous low voltage going through this reed switch, except as it "tips" at which time the +5 Volts DC is shorted, and thus there is a possibility

of corrosion build up on the switch over time.

- The reed switch is easily replaced and the parts are available from your local Rain Bird Distributor.

**TEMPERATURE AND  
RELATIVE HUMIDITY SENSOR**

*Refer to schematic wiring diagram - located in the Appendix - FIGURE 32*

- Set the meter to DC volts and check across pins #4 & #6 for 12VDC.

**DO NOT** connect an OHM meter across the RH chip or damage may occur to the RH chip. If you are experiencing problems with the temperature and relative humidity probe - determine the following:

- Are both the temperature and humidity readings "bad" ?
- Is just the temperature reading "bad"?
- Is the RH reading "bad" ?
  
- If just the RH readings are "bad" - then the RH chip most likely needs to be replaced. New RH chips, for

replacement, are available from your local Rain Bird Distributor.

**AIR TEMPERATURE PROBE  
( ON REDUCED SET STATION  
ONLY )**

*Refer to schematic wiring diagram - located in the Appendix - FIGURE 33*

- Set meter to OHMS and measure from E1 to 1H (pins #3 to #1) should read a minimum of 249K OHMS. Colder temperatures result in higher resistances.
- With meter on OHMS measure from 1H to AG (pins #1 to #5). Should have a fixed reading of 1K OHMS resistance.
- With meter on OHMS measure from E1 to 1L (pins #3 to #2) should read a minimum of 249K OHMS. Colder temperatures result in higher resistances.
- With meter on OHMS measure from 1L to AG (pins #2 to #5). Should have a fixed reading of 1K OHMS resistance.

**TROUBLESHOOTING:**

The following information is for troubleshooting the weather station only.

## ISOLATING THE PROBLEM

The recommended approach to troubleshooting the weather station is to divide the system into three (3) sections, the weather station itself, the communication path or network and the device for communication (computer hookup). Isolate these sections and test each one to find the problem.

## CHECKING THE WEATHER STATION:

Check the weather station by using the ML-10-KD keyboard display. If the ML-10-KD is not available, you may also use a laptop computer along with a serial cable, as shown in FIGURE 25 under "Using a Laptop Computer".

### USING the ML-10-KD KEYBOARD DISPLAY

Connect the keyboard display to the Serial I/O connector on the back of the ET Enclosure behind the cable cover. Refer to FIGURE 24 below.

Remove the cable cover. Remove the cap from the Serial I/O connector and plug the keyboard display cable into the connector.

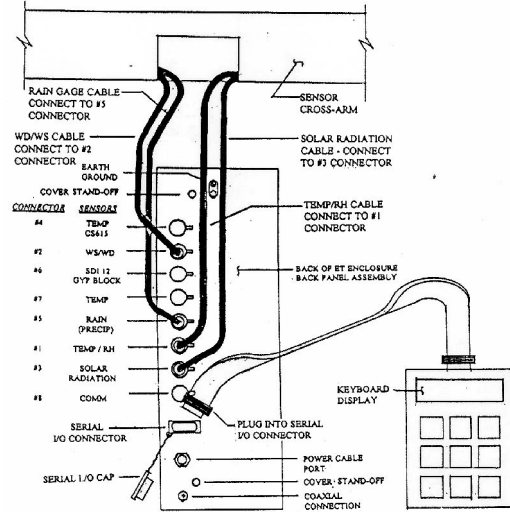

FIGURE 23 - USING THE ML-10-KD KEYBOARD DISPLAY

With the Keyboard display plugged into the Serial I/O connector on the back of the ET Enclosure, there should be power to the I/O connector and now to the keyboard display with the display now being active.

Enter [**\*6**] on the keyboard keypad. Then press [**A**] to advance to the first location (location #1) which is the Battery Voltage. You can ADVANCE to each of the next locations by pressing the letter [**A**] key. Pressing the letter [**B**] key will BACK-UP to the previous location. By entering [**\*0**] you can leave the ML-10-KD in a "low energy mode".

The location values are not important at this time, as long as values are present.

After looking at all the locations needed be sure to do a [**\*0**] to place the micro logger in a low energy mode to conserve battery charge.



<b>DATALOGGER LOCATION TABLE</b>		
<u>Location</u>	<u>Reading</u>	<u>Normal Range</u>
1 = Battery Voltage	~	12.9 to 14.2 Volts
2 = Air Temp. C	~	close to air temp
3 = Relative Humidity	~	0 to 100%
4 = Wind Run	~	Total Wind
5 = Solar Radation	~	0 to 1.2 kW m-2
6 = Rain Fall	~	0 to 2 Inches
7 = Wind Direction	~	0 to 359 degrees
8 = Air Temperature	~	F degrees
9 = RH2	~	0 to 100%
10 = Wind Speed	~	MPH
13 = Enclosure RH	~	-40 degree to + 50 degree C or 10% to 30% when sealed for several hours.

**TROUBLESHOOTING  
PROBLEMS**

**No display on the ML-10-KD keyboard.**  
(If there is display but NO response to input on the keyboard - continue with the next diagnostic problem below.)

If you see NO display on the keyboard then there is NO power output from the datalogger of the weather station.

Pins 1 and 2 of the Serial I/O connector should give +5 Volts DC.

If NO voltage is found - then check for incoming power to the weather station - starting at the transformer check for 110 volts AC power to the transformer.

Check for +16 Volts AC coming from the secondary side of the transformer.

Check for +16 Volts AC at the two (2) terminals marked "CHG" on the panel of the ET Enclosure. (Refer to FIGURE 9 for location of +16VAC terminals).

If you have power all the way to the datalogger PC board - then you must replace the datalogger PC board and have the original datalogger PC board repaired.

**No response using the keypad and/or erroneous letters in the display.**

(If still NO response to keypad input - then continue with the next diagnostic problem below.)

Check keypad response after each of the following steps:

- Make sure the battery has been installed.
- Use a voltmeter to measure the voltage on the 12V and G terminals; the voltage must be between 9.6 and 16 VDC.
- Disconnect any communications or storage peripherals from the datalogger.
- Enter [\*] and wait a short time, at least two (2) minutes for the datalogger to see the keyboard - you should get 00:00 or some other characters on the display. Enter a [\*0] and you should get LOG 1. Continue with [\*6] followed by entering [A] to advance to the next location. Continue to press [A] to check ALL locations of the datalogger.
- If still no response to keypad input - then continue with the next diagnostic problem below.

**No response from datalogger through SC32A or modem peripheral.**

**At the datalogger:**

- Make sure the battery has been installed.
- Use a voltmeter to measure the voltage on the 12V and G terminals; the voltage must be between 9.6 and 16 VDC.
- Make sure the datalogger is disconnected from the modem.

**At the computer:**

- Make sure the Station File is configured correctly.
- Check the cable(s) between the serial port and the modem. If cables are not those furnished with the weather station, then check for the following configuration using an ohm meter:

***25-pin serial port:***

computer end                      modem end

2	2
3	3
7	7
20	20

***9-pin serial port***

computer end                      modem end

2	3
3	3

4 20  
5 7

- Make sure the modem is properly configured and cabled.

If still no response, contact your local Rain Bird distributor.

***-99999 Displayed in an input location.***

- Make sure the battery voltage is between 9.6 and 16 VDC.
- Make sure the Range parameter in the measurement instruction covers the full scale voltage output by the sensor.

***Unreasonable results displayed in an input location.***

- Inspect the sensor for damage and/or contamination.
- Make sure the sensor is properly wired to the datalogger.
- Check the multiplier and offset parameters in the measurement instruction.

***6999 or 99999 stored in final storage.***

- Connect the Laptop computer, using the serial cable as shown in FIGURE 25, to the Serial I/O connector on

Final Storage format limitations are exceeded (no number larger than 6999 in low resolution, or 99999 in high resolution is stored). Change the datalogger program.

**USING A LAPTOP COMPUTER**

When a Laptop computer is being used to check the weather station it is necessary to use a Serial cable between the computer and the weather station, as configured in FIGURE 24 shown below.

**CAUTION!** **Before** "plugging" the serial cable and computer into the Serial I/O connector on the back panel of the Enclosure - make certain that you have disconnected the 9-pin ribbon cable from the Short Haul Modem or the Phone Modem. If you fail to do so, it is a high possibility that you will damage the modem.

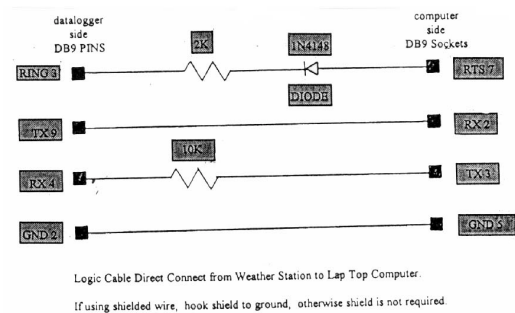

**FIGURE 24 - CONFIGURATION OF SERIAL CABLE**

the back panel of the Enclosure - the same as shown for the Keyboard Display in FIGURE 24.

- Start-Up the Weather Software and set the configuration up for the proper communication port.
- Be sure a direct connect weather station has been configured.
- Enter a capital [W] from the main menu.
- Enter the security code [6275].
- Choose a direct connect Weather Station to monitor and the screen will go "BLANK".
- Press the [ENTER] key until you see an (\*).
- Enter [7240L].
- Enter [7H].
- Enter [\*6].
- [ENTER] [ENTER] - Continue to [ENTER] and this will give you all the data locations and the current readings or each.
- Enter [\* ] to put the datalogger in a low energy mode.

## CHECKING THE COMMUNICATIONS

### WIRE PATH:

Before initially connecting a direct connect or phone line weather station, or when troubleshooting the weather station and the communication wiring is suspect, check the communication wires for their integrity.

### **LOOP RESISTANCE**

Connect the pair of wires, you will be checking, together at the far end. Using a volt/ohm meter, measure across the wire loop. A "GOOD" wire path has less than **600 OHMS** resistance across the loop.

### **GROUND RESISTANCE**

Disconnect the communication wires at the MSP-1 pipe surge arrestor, located at the Weather Station. Using a volt/ohm meter, set the dial to **R x 1K** and measure from each wire to earth ground. A "GOOD" wire path has a high resistance to earth ground, of at least **750,000 OHMS** or greater.

### **A "WS-PRO-SH" DIRECT CONNECT WEATHER STATION**

*Weather Station will not answer.*

Test the wire path using a known

"Good" **RAD SRM-5A** Short Haul Modem.

**First:** Check that the RAD Short Haul Modem, at the central computer location, is working correctly. This can be easily done by using the following method.

- Jumper the output terminals of the **RAD SRM-5A** Short Haul Modem, located at the computer, as shown in **FIGURE 26** below.
- Using a working ("Good") RAD SRM-5A Short Haul Modem connect the communication wires together at the weather station end as shown in **FIGURE 26** below.
- With the Rain Bird Weather Software, go to the Main Menu
- Be sure to configure a direct connect weather station.
- Press a capital [W] from the Main Menu screen.
- If a security number is asked for use [6275].
- Choose a direct connect station and the screen will go "BLANK".
- Assuming you have connected the output terminals of the modem as shown in **FIGURE 25** below, what you type will be echoed back to the computer screen. Testing the short haul modem in this way will verify that it is working properly. If you do not see the characters, that you type, on the screen then the Short Haul Modem has a problem or the COM port and needs to be replaced.

and set the "capital lock" on the keyboard of the computer.

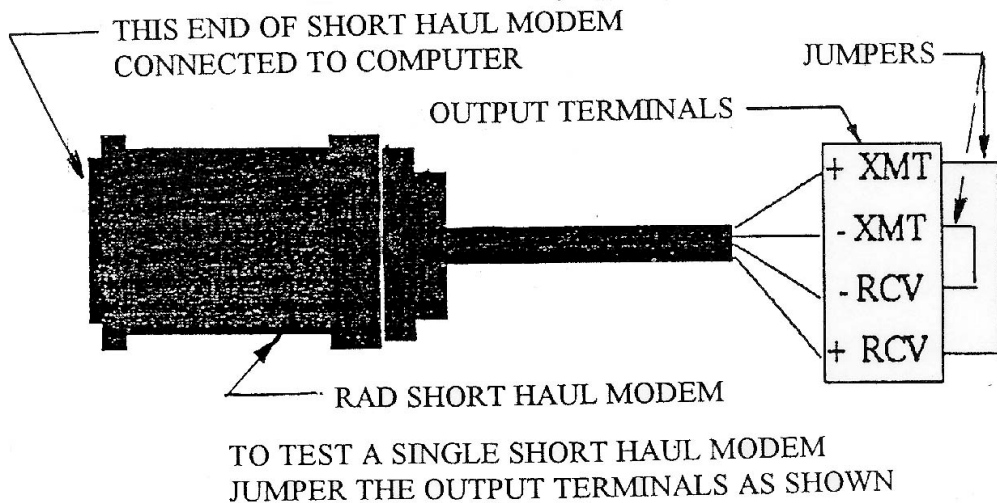

**FIGURE 25 - TEST OF SHORT HAUL MODEM**

**Second:** After having determined, with the test above that the RAD modem at the computer is "Good" - you can then check to see if the communication path, between the computer and the weather station is "Good".

- Re-connect the field communication wires to the RAD modem output terminals, of the RAD modem at the central computer location.
- At the Weather Station, disconnect the communication wires from the MSP-1 pipe surge arrestors and tie the wires together as shown in FIGURE 26 below.
- With the Rain Bird Weather Software, go to the Main Menu and set the "capital lock" on the keyboard of the computer.
- Be sure to configure a direct connect weather station.
- Press a capital [W] from the Main Menu screen.

- If a security number is asked for use [6275].
- Choose a direct connect station and the screen will go "BLANK".
- Assuming you have connected the communication wires correctly at the weather station end, as shown in FIGURE 26 below, what you type at the computer will be echoed back to the computer screen. Testing in this way will verify that the communication wiring is "Good". If you do not see the characters on the screen, that you have typed, then you know that there is a problem with the communication wiring.

**NOTE !** Remember that you have a "spare" pair of communication wires in the Belden #9883 cable. Using this spare pair substitute it for one of the other pairs and test again. If it is not this pair that are "bad" then substitute the "spare" pair for the other pair and test again. In this way you should be able to determine which pair are "bad" and use the "spare" pair in their place.

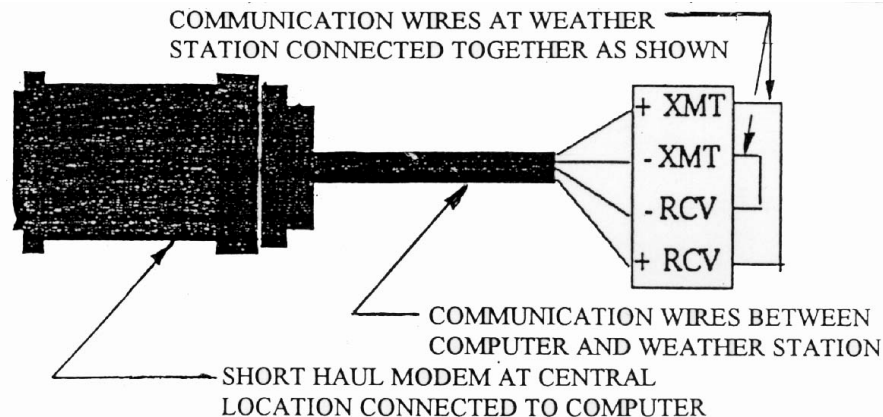

**FIGURE 26 - TEST OF COMMUNICATION WIRES**

**A "WS-PRO-PH" PHONE  
CONNECT WEATHER STATION**

**Weather Station will not answer.**

- Check the weather station for operation on it's own to be sure it is functioning properly. This will verify the proper voltage coming into the weather station and also if the datalogger checks out O.K.
- Connect a telephone to the phone line at the weather station and call out, or have someone call in. Listen for any noise on the line. **Refer to NOTE below.**

**NOTE !** A phone line going to the computer or to the weather station itself **MUST BE DATA QUALITY.** You can talk over a phone line that will NOT allow data communication.. Listen for any fuzzy noises and any disturbance at all. You must be sure the phone line is "Good". Time and time again we have set up stations and the phone line is NOT good enough for communication. Make sure the phone company knows this will be for data communication. Have Phone Company check line ALL the way back to the weather station.

- If the station is still not answering, get your volt/ohm meter and measure across the phone line. It should read approximately 48 Volts DC, with the Ring as the positive side and the Tip the negative side.
- Have someone call in and then measure the voltage across the phone line. It should read 90 to 110 Volts

AC. The answer modem switch circuit requires 40 Volts to activate and allow the signal to pass to the datalogger.

- The Datalogger detects the ring and raises the modem enable line high (pin 5), to +5 Volts DC. (Measure pin 5 to ground).

**CAUTION !** Connect a volt/ohm meter to the phone line only in extreme cases. It is recommended to use FCC approved equipment only - while measuring current on a telephone line.

**USE NO MSP-1,** pipe surge arrestor on the telephone communication wires. If an MSP-1 pipe surge arrestor is used in the line, the Weather Station will usually answer and then hang up right away. The MSP-1 is for low voltage applications and the telephone line is excited to well over the 50 volt limit of the MSP-1 surge arrestor so will shunt the line to earth ground.

- Test the phone modem, at the weather station by dialing out to the weather station. It is working and is O.K. if you can hear a dial tone and the dialing. This also verifies the communication path and most modem settings.
- If telephone line appears to be O.K. - then change the phone modem at the weather station, to a known "Good" phone modem and try again.
- If the station still does not answer, then have the telephone company check the phone line again, even if

it is the fourth time they have been out.

**COMPUTER MODEM AND COMMUNICATION TROUBLESHOOTING:**

*Weather Software will not communicate with the weather station.*

- Verify all the wiring, etc., at the computer, to the modem, and to the field.
- Be sure the software is configured to the correct communication port according to the type of MAXI software being used for the system; i.e., MAXI 5, NIMBUS or CIRRUS. If you arrive at weather through MAXI then the serial port is configured through the MAXI software.
- A data line monitor may be necessary to test the output from the computer and to verify that the serial port is working O.K. Most times output can be verified, however, with RAD Short Haul Modem or a phone modem. A data line monitor RS-232 Mini-Tester (available at Radio Shack) is a device that connects into the line with the serial port and by using lights will show the status of all the data lines.
- It is important here to check the communication serial port of the computer and verify that it is functioning correctly, just as is required when troubleshooting MAXI or MAXICOM.

**TESTING THE SHORT HAUL MODEM**

For the older weather stations, which used the RAD SH-6A Short Haul Modems and the current "PRO" weather stations, which use the RAD SRM-5A Short Haul Modems - both of these modems can be tested in the same manner.

- With the modem connected to the computer, jumper the output terminals of the RAD modem as shown in FIGURE 25.
- With the Rain Bird Weather Software, go to the Main Menu and set the "capital lock" on the keyboard of the computer.
- Be sure to configure a direct connect weather station.
- Press a capital [W] from the Main Menu screen.
- If a security number is asked for use [6275].
- Choose a direct connect station and the screen will go "BLANK".
- Assuming you have connected the output terminals of the modem as shown in FIGURE 26, what you type will be echoed back to the computer screen. Testing the Short Haul Modem in this way will verify that it is working properly. If you do not see the characters, that you type, on the screen then the Short Haul Modem has a problem and needs to be replaced.

If you have the very old type Short Haul modem - it should be replaced with the



newer type RAD SRM-5A modem, if at all possible.

- If the old SH-95C modem is working properly you can measure +7 Volts DC across the (SRC) and the (RET), during a rest period. This is only when the computer is out of the MAXI program and the Weather program. If the computer is running Weather then the reading will jump to +15 Volts DC.
- On the old SH-95C modem there is a ring button, and the voltage level will go up to +15 volts DC when you push this button, and return to +7 Volts DC upon release & when the communication cable is disconnected from the SC95A.
- If these voltages do not exist, then you must replace the modem or have the modem repaired.

3	DOWN	Result codes sent to computer
4	DOWN	Characters not echoed
5	DOWN	Auto-Answer disabled
6	DOWN	Carrier detect always on
7	UP	Single Line RJ11 phone jack
8	DOWN	Enables
Commands		
9	UP	Compatible with Bell 103/212A modems
10	UP	Modem Reset when turned on

**TESTING THE PHONE MODEM**

If a Hayes Model 1200 or 2400 Smart Modem is being used to communicate with the Weather Station - be sure the switch settings are as follows:

<u>SW #</u>	<u>Setting</u>	<u>Function</u>
1	DOWN	Ignores DTR
2	UP	English word result codes

<u>SW #</u>	<u>Setting</u>	<u>Function</u>
-------------	----------------	-----------------

Test the phone modem by dialing out to the weather station. It works if you can hear a dial tone and the dialing. This verifies the communication path and most modem settings.

A phone line going to the computer or the weather station itself must be of DATA QUALITY. You can talk over a phone line that will not allow data communication. Listen for any fuzzy noises and any disturbance at all. If the modem keeps "HANGING UP", this is an indication of either an incorrect setting or a bad phone line.

## Appendix

### **UPGRADING A MODEL "JR" WEATHER STATION TO A MODEL PRO WEATHER STATION:**

The Model JR weather station can be easily converted to a Model PRO weather station by the use of the "Upgrade" kit.

This "Upgrade" kit gives the additional instrumentation of a tipping bucket rain

gauge, wind direction indicator and wind speed indicator.

**Refer to main section of this manual  
for complete details:**

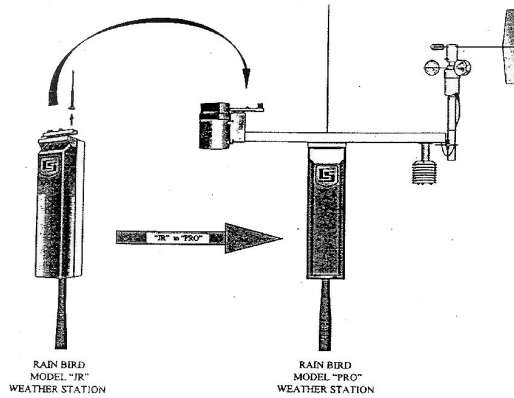

**FIGURE 27 - UPGRADE KIT**

**TYPICAL 3-ROD GROUNDING GRID:**

Grounding grids are required at the Central equipment location, for the weather station (grounding grid for the central equipment may also be used for the weather station if accessible) and at the weather station itself.

A typical 3-rod grounding grid shall consist of three (3) 5/8" diameter x 8'-0" long copper clad grounding rods. The rods shall be in a triangular arrangement, if at all possible, with each rod at least 8'-0" away from any other rod.(refer to **FIGURE 28** below). If it is impossible to arrange the rods in a triangular pattern then they may be arranged in a straight line (although NOT as effective) with each rod at least 8'-0" from any other rod.

NOTE! If longer than 8'-0" rods are used, then the rods shall be spaced no closer than the length of the rod from each other.

The 3 rods shall be driven into the ground with top of rod at least six inches (6") below the finish grade. The rods shall be tied together below grade with #10 gauge or larger bare copper wire. The wire shall be attached to the rod using a brass clamp. A separate brass clamp shall be used for each attachment.

NOTE ! No more than one wire shall be used in any individual clamp. Multiple wires shall NOT be allowed.

Any rod that has a ground wire connected to it, coming from the surge arrester at the equipment or grounding the equipment, shall have a standard 18" x 24" rectangular valve box installed around the top of the rod. This shall provide future access to inspect and/or maintain the MGP-1 grounding plate assembly, MSP-1 pipe surge arrestors, brass clamp and ground wire should this be necessary. Any of the other rods in the grid shall have a standard 6" diameter round valve box installed around the top of the rod for future access.

Where MSP-1 pipe surge arrestors are required on the communication path wiring, the MSP-1 pipe surge arrester shall be mounted on an MGP-1 grounding plate assembly. The MGP-1 grounding plate assembly in turn shall be securely attached to one of the grounding rods of the 3-rod grounding grid. Attach the MGP-1 to the ground rod that

is nearest to the equipment, so as to have a minimum of exposed wire between the equipment and the surge arrester itself.

Use 3M - DBY or DBR Direct Burial splice kits for ALL wire splices.

**GROUND RESISTANCE** - With the 3-rod grounding grid we are attempting to get a ground resistance of **5 OHMS** or less, if at all possible. Any thing above 15 OHMS is of little value for protection. In order for the surge arrestors to be effective they must be able to discharge to ground rather than allow the surge to go to the electronic components. Therefore the "HIGHER" the resistance to ground (higher OHM reading) the chance of the surge being shunted to ground rather than go to the electronic components. From this you can see that it is also important to maintain a "Good Ground" at ALL times.

**BENTONITE CONTACT:** In using grounding rods we are depending upon the "contact" of the surface of the rod to the soil. The greater the contact the better chance we have of obtaining a "good" ground. If you are in a soil type that you know will not give good surface contact with the rod, you may want to consider drilling a 4" to 6" diameter hole in which to place the ground rod. You can then back fill around the rod with Bentonite or other similar material that is very dense and in this way increase the contact of the rod with the soil.

**ROCKY CONDITIONS:** In areas where you are unable to drive a rod or to bore a hole for a rod, you may need to consider laying the rods horizontal 12

inches or so below the surface on a good 6" deep bed of soil or Bentonite. Again rods should be 8'-0" apart and tied together with #10 gauge or larger bare copper wire at both top and bottom of the rods to form a grid.

**ROCK LAYER:** Where a rock layer is found under a shallow layer of soil, a 4'-0" x 4'-0" square piece of sheet steel, 3/8" to 1/2" thick, should be considered to be laid horizontally on a 4" thick layer of soil or Bentonite over the rock layer. A bolt or short piece of steel rod welded to the plate will provide a means of connection to the steel plate. The plate should be covered to finish grade with good top soil.

**IMPROVING EARTH GROUNDS:** When a grounding grid is first installed you are unable to get a true OHMs reading, since the rod surface will not be in good contact with the soil. The grid must be installed for 5 or 6 weeks before a meaningful reading can be obtained. It is also recommended that the grounds be checked at least once a year and in severe lightning areas perhaps as often as two or three times a year.

NOTE ! A good reading CANNOT be obtained with a volt/ohm meter. A Meggar or Vigma-Ground type instrument must be used to check the ground resistance.

If unsatisfactory readings are obtained, the ground may be improved in one of the following ways:

- (1) Extend a #6 or larger bare copper braided wire from one of the rods out across a fairway and buried a minimum of 12" below the surface.

Be sure the wire is between rows of sprinklers and away from other wires, pipes, etc. as far as possible. This will place the wire in an area that will be frequently watered and will increase the surface contact of the grounding network.

- (2) In the center of the triangle, of the 3-rod grid, install an 8'-0" long piece of 6" diameter perforated plastic pipe. Top shall be at least 6" below the finish grade. Fill this pipe with rock salt, Epson salts, or other suitable similar material and water it down. The salt will leach out into the soil and corrode the surface of the rods giving improved and greater surface contact. Place a 6" diameter valve box cover over the end of the pipe and cover it with soil to finish grade.

**MSP-1 PIPE SURGE ARRESTORS:**

Each of the pairs of wires in the communication path, between the central computer and the weather station,

shall be wired through an MSP-1 pipe surge arrestor, at both the computer end and at the weather station end. The MSP-1 pipe surge arrestors shall be located as close to the equipment it is to protect as is practical. The MSP-1 pipe surge arrestors shall be mounted in MGP-1 grounding plate assemblies.

The MSP-1 pipe surge arrestor is marked, "EQUIP" on one end and "LINE" on the other end. When installing the MSP-1 be sure that the end marked "EQUIP" is located "toward the equipment" it is to protect, i.e., computer or weather station. The "LINE" end goes toward the field.

The Green wire on each end of the MSP-1 pipe surge arrestor shall be attached to one of the grounding screws on the MGP-1 grounding plate assembly.

**REFER TO FIGURE 28 ON THE NEXT PAGE**

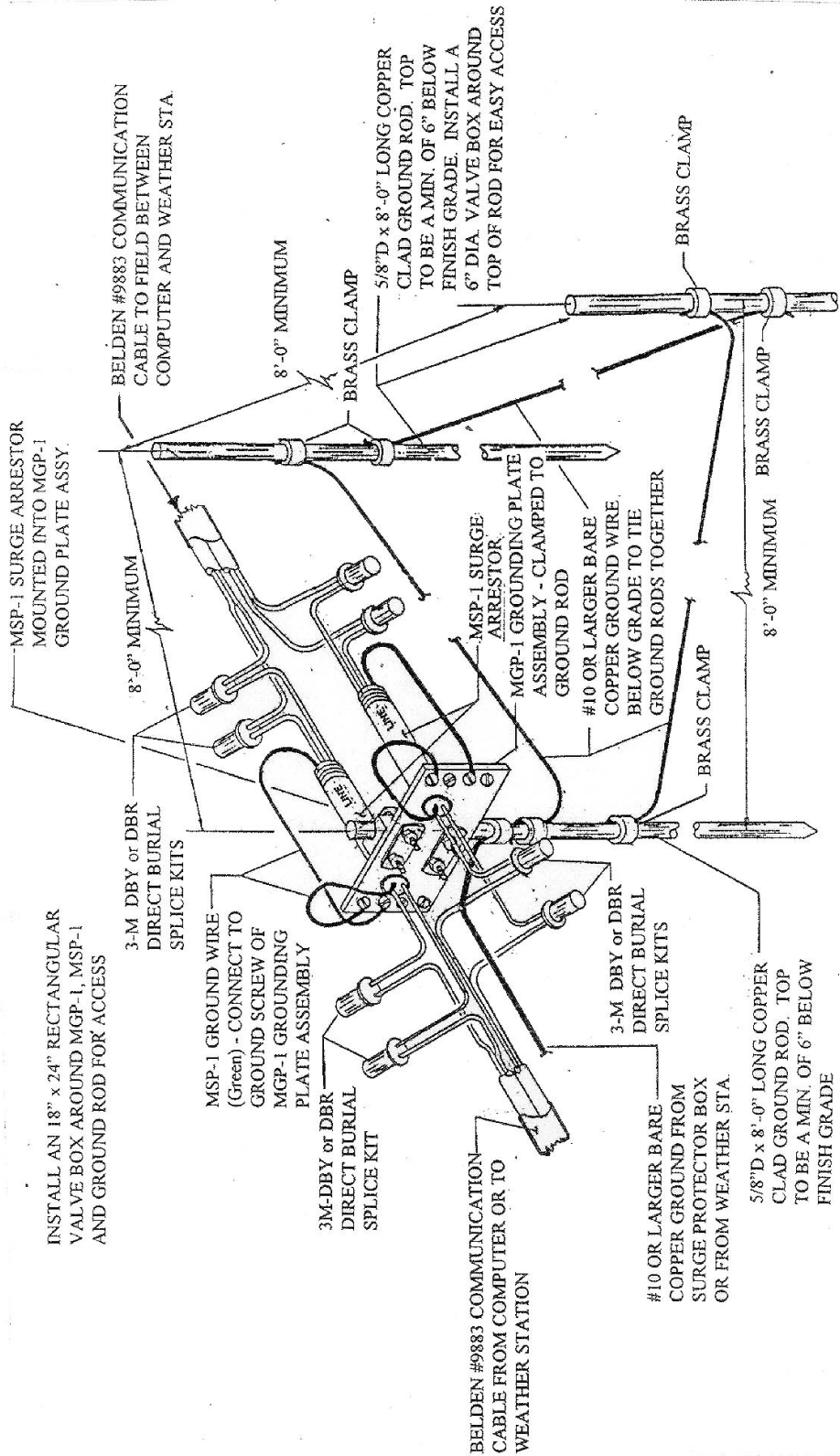

FIGURE 28 - TYPICAL 3-ROD GROUNDING GRID DETAIL

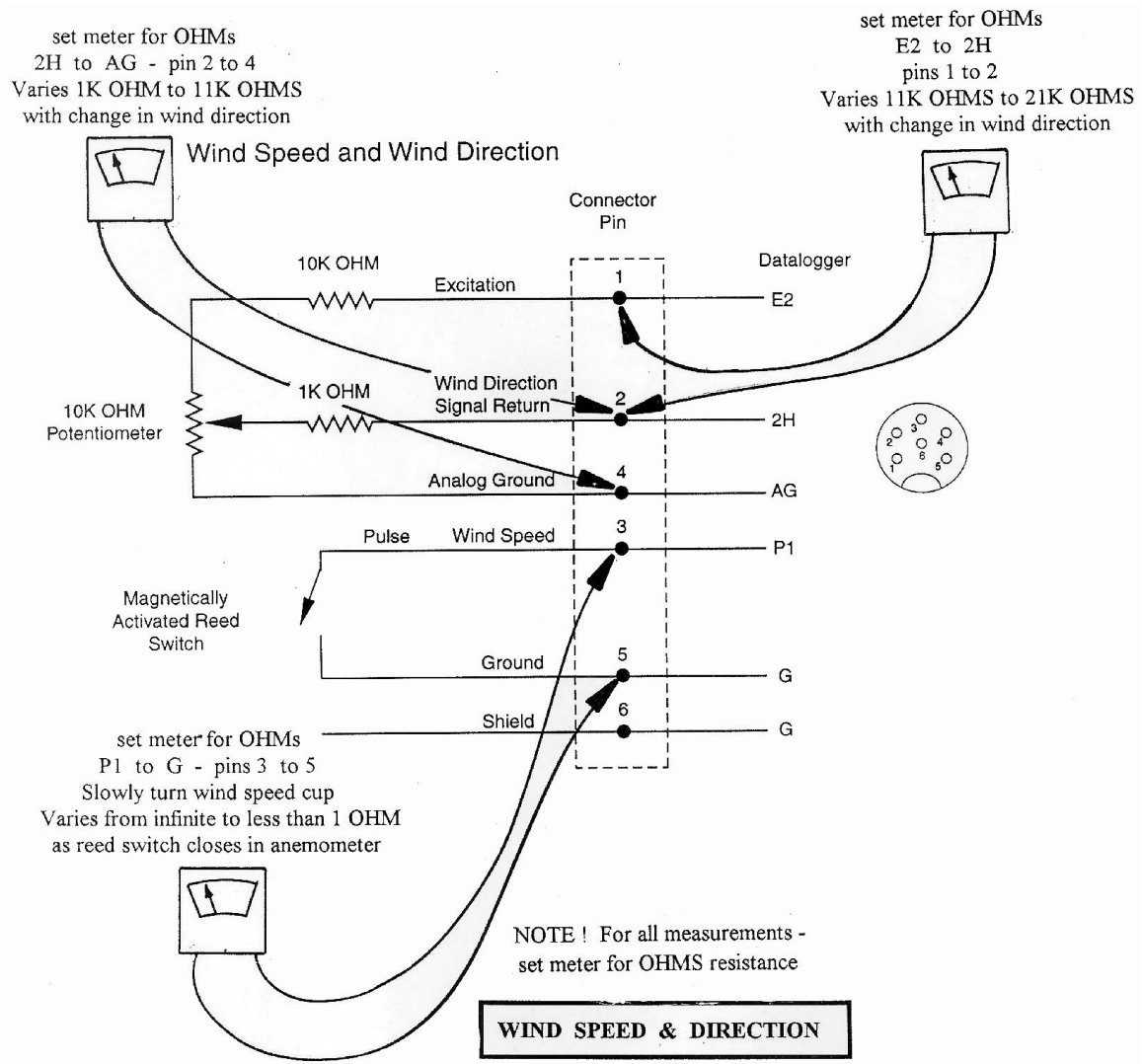

FIGURE 29 - TESTING OF WIND SENSOR

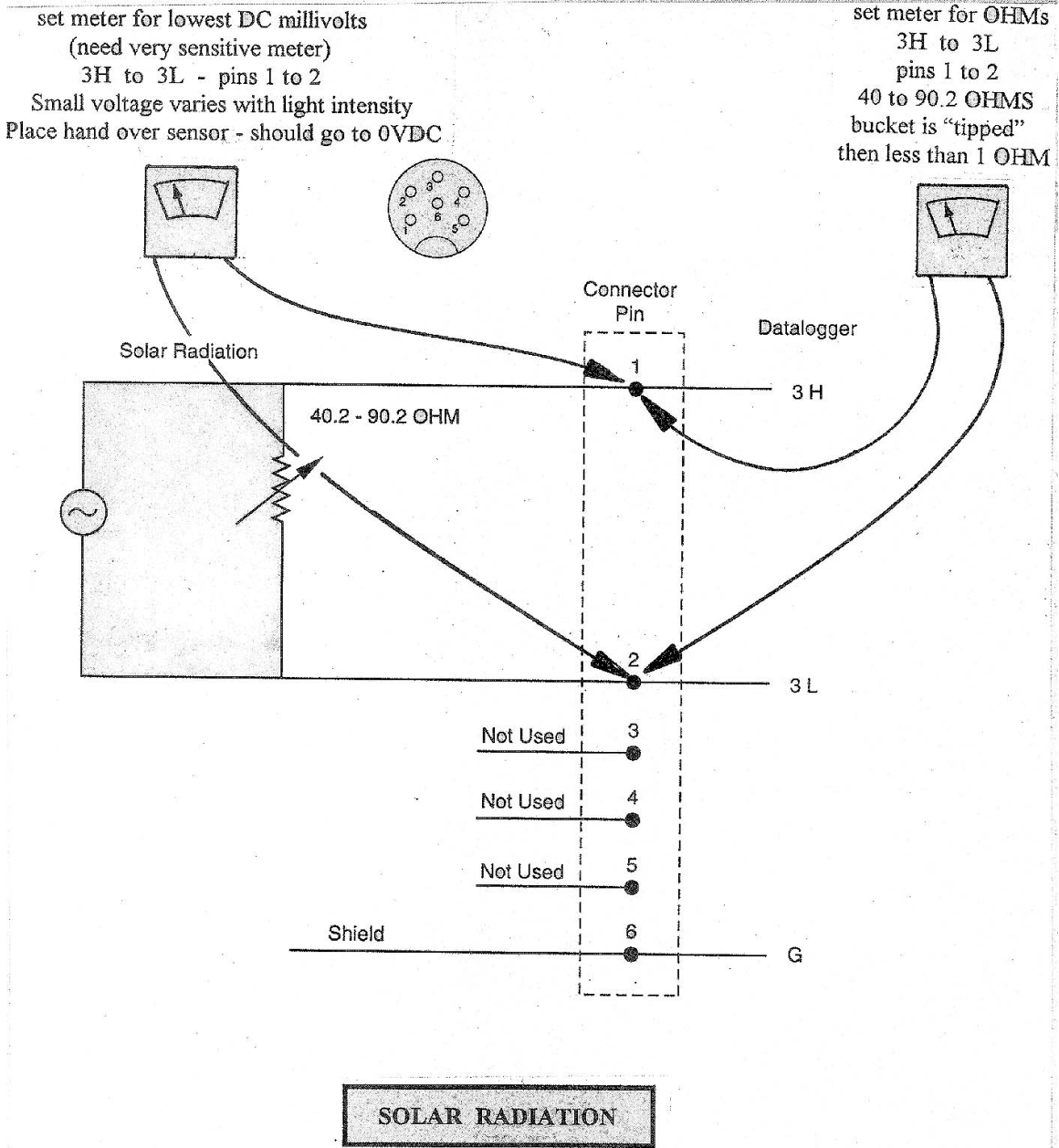
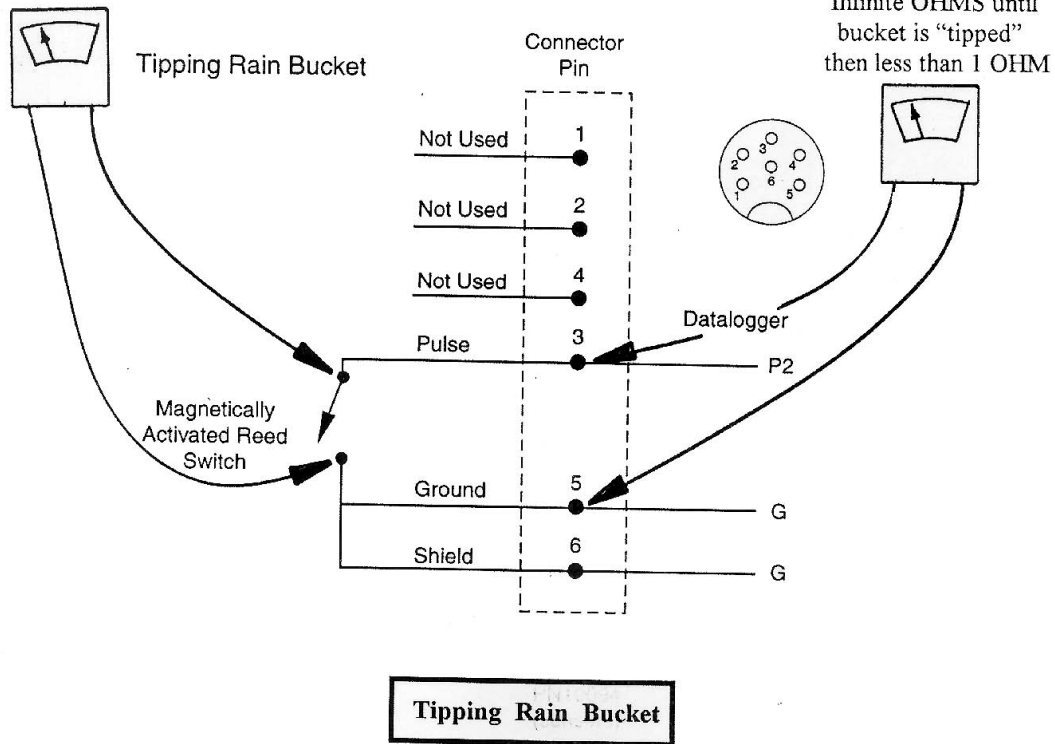

FIGURE 30 - TESTING OF SOLAR RADIATION SENSOR



set meter for DC volts  
 (low scale - 5.0VDC)  
 Measure across Reed Switch  
 5VDC until bucket is "tipped"  
 & switch closes - then 0VDC

set meter for OHMS  
 P2 to G  
 pins 3 to 5  
 Infinite OHMS until  
 bucket is "tipped"  
 then less than 1 OHM



**FIGURE 31 - TESTING OF RAIN GAGE**

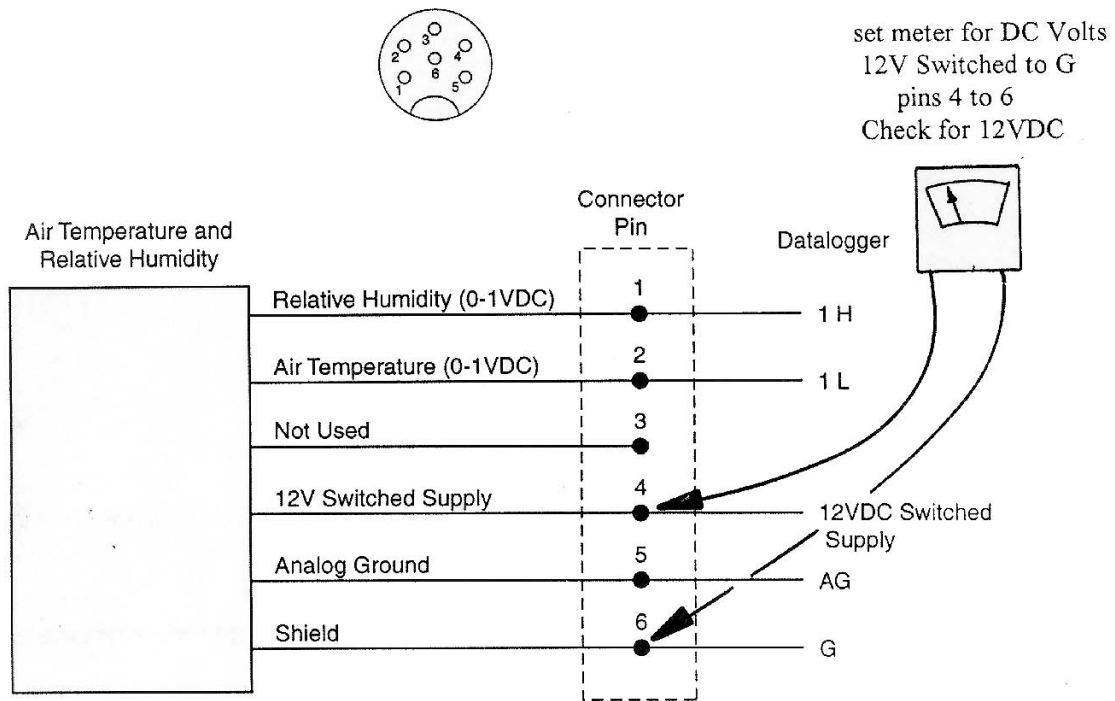

There are NO other measurements that can be made with a Volt/Ohm meter

**AIR TEMPERATURE & RELATIVE HUMIDITY**

**FIGURE 32 - TESTING OF TEMPERATURE/RELATIVE HUMIDITY SENSOR**

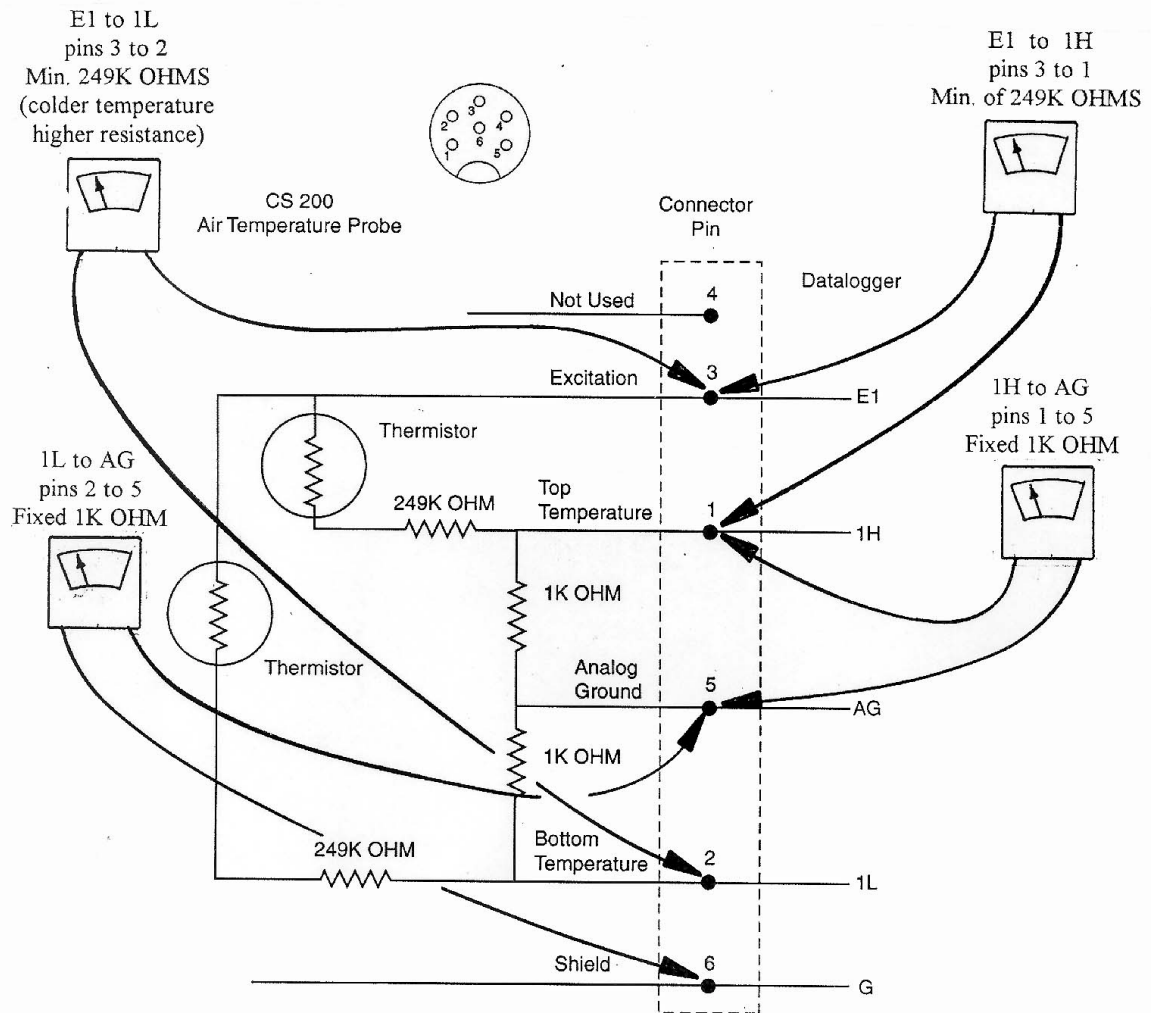

NOTE ! For all measurements - set meter for resistance (OHMS)

**CS 200 Air Temperature Probe**

**FIGURE 33 - TESTING OF AIR TEMPERATURE PROBE**

