

# INSTRUCTION MANUAL



## AM16/32A Relay Multiplexer

Revision: 11/07



Copyright © 1987-2007  
Campbell Scientific, Inc.

# **Warranty and Assistance**

---

The **AM16/32A RELAY MULTIPLEXER** is warranted by CAMPBELL SCIENTIFIC, INC. to be free from defects in materials and workmanship under normal use and service for twelve (12) months from date of shipment unless specified otherwise. Batteries have no warranty. CAMPBELL SCIENTIFIC, INC.'s obligation under this warranty is limited to repairing or replacing (at CAMPBELL SCIENTIFIC, INC.'s option) defective products. The customer shall assume all costs of removing, reinstalling, and shipping defective products to CAMPBELL SCIENTIFIC, INC. CAMPBELL SCIENTIFIC, INC. will return such products by surface carrier prepaid. This warranty shall not apply to any CAMPBELL SCIENTIFIC, INC. products which have been subjected to modification, misuse, neglect, accidents of nature, or shipping damage. This warranty is in lieu of all other warranties, expressed or implied, including warranties of merchantability or fitness for a particular purpose. CAMPBELL SCIENTIFIC, INC. is not liable for special, indirect, incidental, or consequential damages.

Products may not be returned without prior authorization. The following contact information is for US and International customers residing in countries served by Campbell Scientific, Inc. directly. Affiliate companies handle repairs for customers within their territories. Please visit [www.campbellsci.com](http://www.campbellsci.com) to determine which Campbell Scientific company serves your country. To obtain a Returned Materials Authorization (RMA), contact CAMPBELL SCIENTIFIC, INC., phone (435) 753-2342. After an applications engineer determines the nature of the problem, an RMA number will be issued. Please write this number clearly on the outside of the shipping container. CAMPBELL SCIENTIFIC's shipping address is:

**CAMPBELL SCIENTIFIC, INC.**

RMA#\_\_\_\_\_

815 West 1800 North

Logan, Utah 84321-1784

CAMPBELL SCIENTIFIC, INC. does not accept collect calls.

# AM16/32A Relay Multiplexer

## Table of Contents

---

*PDF viewers note: These page numbers refer to the printed version of this document. Use the Adobe Acrobat® bookmarks tab for links to specific sections.*

<b>1. Function</b> .....	<b>1</b>
1.1 Typical Applications.....	1
1.2 Compatibility.....	2
<b>2. Physical Description</b> .....	<b>2</b>
<b>3. AM16/32A Specifications</b> .....	<b>3</b>
<b>4. Operation</b> .....	<b>5</b>
4.1 The Control Terminals.....	5
4.1.1 Reset.....	6
4.1.2 Clock.....	6
4.1.3 Ground.....	7
4.1.4 Power Supply.....	7
4.2 Measurement Terminals .....	8
4.2.1 COM Terminals .....	9
4.2.2 Sensor Input Terminals .....	9
<b>5. Datalogger Programming</b> .....	<b>10</b>
5.1 Single Loop Instruction Sequence .....	11
5.2 Multiple Loop Instruction Sequence.....	16
5.3 CRBasic Programming .....	18
5.3.1 CR5000 and CR3000 Programming .....	19
5.3.2 CR1000, CR800, and CR850 Programming .....	20
5.4 General Programming Considerations.....	22
<b>6. Sensor Hook-up and Measurement Examples</b> .....	<b>22</b>
6.1 Single-Ended Analog Measurement without Sensor Excitation .....	22
6.2 Differential Analog Measurement without Sensor Excitation .....	23
6.3 Half Bridge Measurements .....	24
6.3.1 Half Bridge Measurement with Completion Resistor at Datalogger .....	24
6.3.2 Potentiometer Measurement.....	25
6.3.3 Four Wire Half Bridge (Measured Excitation Current).....	25
6.4 Full Bridge Measurements.....	26
6.5 Full Bridges with Excitation Compensation .....	27

6.6 Thermocouple Measurement..... 28  
 6.6.1 Measurement Considerations ..... 28  
 6.6.2 Single-ended Thermocouple Measurement ..... 30  
 6.6.3 Differential Thermocouple Measurement ..... 31  
 6.7 Mixed Sensor Types..... 31  
 6.7.1 Mixed Sensor Example: Soil Moisture Blocks and  
 Thermocouples..... 31

**7. General Measurement Considerations .....35**

**8. Installation .....35**

8.1 Mounting Tabs ..... 36  
 8.2 Controlling Humidity ..... 36

**Appendices**

**A. AM16/32A Improvements..... A-1**

**Figures**

1. AM16/32A Relay Multiplexer ..... 3  
 2. AM16/32A Relay Actuation Time vs. Temperature and Battery Voltage.. 5  
 3. AM16/32A to Datalogger Power/Control Hookup ..... 6  
 4. Power and Ground Connections for External Power Supply ..... 8  
 5. Typical AM16/32A to Datalogger Signal Hookup (4x16 Mode)..... 9  
 6. SCWIN (Short Cut for Windows Program Builder) ..... 10  
 7. Example “4x16” Mode Program Loops for CR23X, CR10(X),  
 21X, and CR7 Dataloggers ..... 14  
 8. Example “2x32” Mode Program Loops for CR23X, CR10(X),  
 21X, and CR7 Dataloggers ..... 15  
 9. Wiring Diagram for Strain Gages and Potentiometers ..... 16  
 10. Single-ended Measurement without Excitation..... 23  
 11. Differential Measurement without Excitation ..... 23  
 12. Half Bridge (Modified 107 Temperature Probe) Hook-up and  
 Measurement..... 24  
 13. Potentiometer Hook-up and Measurement..... 25  
 14. Four Wire Half Bridge Hook-up and Measurement..... 26  
 15. Full Bridge Measurement..... 26  
 16. Full Bridge Measurement with Excitation Compensation ..... 27  
 17. Differential Thermocouple Measurement with Reference  
 Junction at the Datalogger ..... 29  
 18. Differential Thermocouple Measurement with Reference  
 Junction at the AM16/32A..... 29  
 19. AM16/32A Aluminum Cover Plate ..... 30  
 20. Thermocouple and Soil Block Measurement ..... 32  
 21. Mounting Tab Hole Pattern..... 36

# ***Cautionary Notes***

---

The AM16/32A is not designed to multiplex power. Its intended function is to switch low level analog signals. Switched currents in excess of 30 mA will degrade the relay contacts involved, rendering that channel unsuitable for further low level analog measurement. Customers who need to switch power are directed to Campbell Scientific's SDM-CD16AC, A6REL-12, or A21REL-12 relays.

Changing the setting of the mode switch from "4x16" to "2x32" connects COM ODD H to COM EVEN H and also COM ODD L to COM EVEN L. After wiring AM16/32A, exercise due care to avoid inadvertently putting excess voltage on a line or short circuiting a power supply which might damage datalogger, wiring panel, sensor or multiplexer (not covered under warranty).



# ***AM16/32A Relay Analog Multiplexer***

---

## **1. Function**

The primary function of the AM16/32A Multiplexer is to increase the number of sensors that can be measured by a CR1000, CR3000, CR800, CR850, CR23X, CR10(X), 21X, or CR7 datalogger. The AM16/32A is positioned between the sensors and the datalogger. The AM16/32A is a replacement for CSI's AM16/32 model. Mechanical relays in the AM16/32A connect each of the sensor channels in turn to a common output destined for the datalogger. The user program advances the multiplexer through the sensor channels making measurements and storing data.

A slide switch located on the AM16/32A's top panel selects one of two modes of operation. In "2x32" mode the multiplexer can scan 32 sensor input channels, each with two lines. In "4x16" mode it can scan 16 input channels with four lines a piece. The datalogger program is written according to the selected mode and the sensors to be measured.

The maximum number of sensors that can be multiplexed by an AM16/32A depends primarily on the type(s) of sensors to be scanned. The following guidelines assume identical sensors:

Up to 32 single-ended or differential analog sensors that do not require excitation. For example: pyranometers and thermocouples (see Sections 6.1, 6.2, and 6.6).

Up to 32 single-ended sensors that require excitation. Example: some half bridges (see Section 6.3.1).

Up to 16 single-ended or differential sensors that require excitation. Examples: full bridges and four-wire half bridge with measured excitation (see Section 6.3.3 and 6.4).

In conjunction with a second AM16/32A, up to 16 six-wire full bridges (Section 6.5).

### **1.1 Typical Applications**

The AM16/32A is intended for use in applications where the number of required sensors exceeds the number of datalogger input channels. Most commonly, the AM16/32A is used to multiplex analog sensor signals, although it can also be used to multiplex switched excitations, continuous analog outputs, or even certain pulse counting measurements (i.e., those that require only intermittent sampling). It is also possible to multiplex sensors of different, but compatible, types (e.g., thermocouples and soil moisture blocks, see Section 6.7.1).

**NOTE** For a discussion of single-ended versus differential analog measurements, please consult the Measurement section of your datalogger manual.

---

As purchased, the AM16/32A is intended for use in indoor, non-condensing environments. An enclosure is required for field or high humidity use. In applications where one or two multiplexers are deployed, the ENC 10/12 (10" x 12") enclosure is recommended.

## 1.2 Compatibility

The AM16/32A is compatible with Campbell's CR5000, CR800, CR850, CR3000, CR1000, CR23X, CR10(X), 21X, and CR7 dataloggers.

The AM16/32A is compatible with a wide variety of commercially available sensors. As long as relay contact current maximums are not exceeded (see Cautionary Notes, page iii), and no more than four lines are switched at a time, system compatibility for a specific sensor is determined by sensor-datalogger compatibility.

In CR1000, CR800, CR850, CR3000, CR23X, and CR10(X) applications the AM16/32A may be used to multiplex up to 16 Geokon vibrating wire sensors through one AVW1 vibrating wire interface.

## 2. Physical Description

The AM16/32A is housed in a 10.2 cm x 23.9 cm x 4.6 cm (4.0" x 9.4" x 1.8") anodized aluminum case (Figure 1). The aluminum case is intended to reduce temperature gradients across the AM16/32A's terminal strips. An aluminum cover plate is also included to this end. This is extremely important if thermocouples are being multiplexed (Section 6.6).

The case can be opened for inspection/cleaning by removing two phillips-head screws located on the under-side of the case. Mounting tabs are provided so the AM16/32A can be fastened to a flat surface or an enclosure plate (Section 8).

All connections to the AM16/32A are made on the top panel terminal blocks. The island of four terminals located near the mode switch are dedicated to the connecting of datalogger power and control lines (Section 4.1). The four "ODD" and "EVEN" "COM" terminals on the other side of the mode switch carry shielded multiplexed sensor signals destined for datalogger analog inputs. The remaining terminals on the AM16/32A are for sensor and sensor shield connection (Section 4.2). All of the inputs of the AM16/32A are protected with gas tubes. The terminals accept stripped and tinned lead wires up to 16 AWG or 1.6 mm in diameter. Datalogger-to-AM16/32A cabling requires a minimum of six and as many as nine individually insulated wires with shields.





FIGURE 1. AM16/32A Relay Multiplexer

### 3. AM16/32A Specifications

<b>Power*:</b>	Unregulated 12 VDC Minimum Operating Voltage: from -55C to +40C = 11.3 VDC; from +40C to +85C = 11.8 VDC (See Figure 2 for relay actuation times vs. temperature and supply voltage.)
<b>Current Drain:</b>	Quiescent: < 210 uA Active: 6 mA typical in "2 x 32" mode 11 mA typical in "4 x 16" mode
<b>Reset*:</b>	A continuous signal between 3.5 VDC and 16 VDC holds the AM16/32A in an active state (where a clock pulse can trigger a channel advance). A signal voltage < 0.9VDC deactivates the AM16/32A (clock pulse will not trigger a scan advance; AM16/32A is also reset).
<b>Clock*:</b>	On the transition from <1.5 V to >3.5 V, a scan advance is actuated on the leading edge of the clock signal; clock pulse should be a minimum of 1 ms wide.
<b>Operational Temperature:</b>	Standard: -25°C to +50°C Extended: -55°C to +85°C
<b>Operational Humidity:</b>	0 - 95%, non-condensing

<b>Dimensions:</b>	Length – 23.9 cm (9.4") Width - 10.2 cm (4.0") Depth - 4.6 cm (1.8")
<b>Weight:</b>	1.5 lbs. (approx.), 693 g.
<b>Mounting Tab Hole Spacing:</b>	1 inch x 3 inches x 9 inches. Up to 1/8 inch or 3 mm diameter screws (see Figure 21).
<b>Expandability** (nominal):</b>	2 AM16/32As per CR800/CR850 4 AM16/32As per CR3000 4 AM16/32As per CR5000 4 AM16/32As per CR1000 4 AM16/32As per CR23X 4 AM16/32As per CR10(X) 4 AM16/32As per 21X 8 AM16/32As per CR7 725 Card
<b>Maximum Cable Length:</b>	Depends on sensor and scan rate. In general, longer lead lengths necessitate longer measurement delays. Refer to datalogger manual for details.
<b>Maximum Switching Current***:</b>	500 mA
<b>Contact Specifications:</b>	Initial contact resistance: <0.1 ohm max. Initial contact bounce: <1 ms Contact material: Gold clad silver alloy Wiper to N.O. contact capacitance: 0.5 pF Typical low-current (<30 mA) life: 5 x 10 <sup>7</sup> operations
<b>Relay Switching Characteristics (applying 11.3 – 14 VDC):</b>	Thermal emf: 0.3 μV typical; 0.5 μV maximum Operate time: <10 ms over temperature and supply ranges Break before make guaranteed by design
<b>ESD:</b>	Air Discharge: complies with IEC61000-4-2, test level 4 (±15 kV) Contact Discharge: complies with IEC61000-4-2, test level 4 (±8 kV)
<b>Surge:</b>	Complies with IEC61000-4-5, test level 3 (±2 kV, 2 ohms coupling impedance)

\* Reset, Clock, and +12V inputs are protected by +16V transzorb.

\*\* Assumes sequential activation of multiplexers and that each datalogger channel is uniquely dedicated. If your application requires additional multiplexing capability, please consult CSI for application assistance.

\*\*\* Switching currents greater than 30 mA (occasional 50 mA current is acceptable) will degrade the contact surfaces of the mechanical relays (increase their resistance). This will adversely affect the suitability of these relays to multiplex low voltage signals. Although a relay used in this manner no longer qualifies for low voltage measurement, it continues to be useful for switching currents in excess of 30 mA.

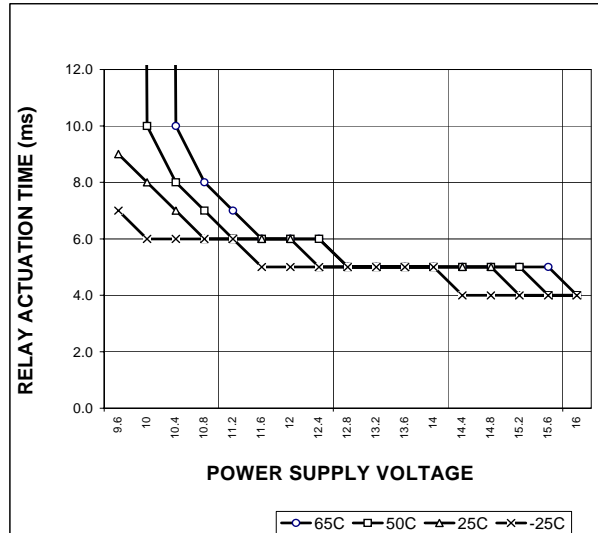

FIGURE 2. AM16/32A Relay Actuation Time vs. Temperature and Battery Voltage.

## 4. Operation

Subsection 4.1 discusses the terminals that control operation of the multiplexer. These terminals are located at the left-hand side of the multiplexer as shown in Figure 1. Subsection 4.2 discusses the use of sensor measurement terminals.

### 4.1. The Control Terminals

The CR5000, CR3000, CR800, CR850, CR1000, CR23X, CR10(X), 21X, and CR7 dataloggers connect to the AM16/32A as shown in Figure 3 (“4x16” mode). Figure 3 depicts control connections. Measurement connections are discussed in Section 6. The power, ground, reset, and clock connections remain essentially the same regardless of datalogger used.

With the CR5000, CR3000, CR800, CR850, CR1000, CR23X and CR10(X) the datalogger 12 VDC supply and ground terminals are connected to the AM16/32A 12V and ground terminals. One control port is required for clocking and a second control port for reset. The MUXPOWER cable (or equivalent) shield is grounded on both ends as illustrated below.

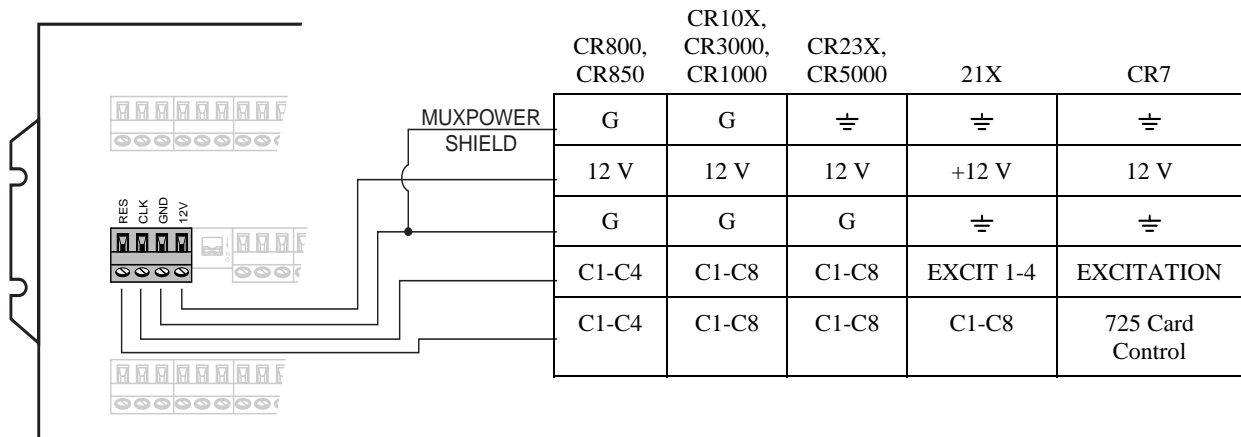

FIGURE 3. AM16/32A to Datalogger Power/Control Hookup

With the 21X or CR7 the AM16/32A connects to the 12 VDC and “≡” terminals for power. One control port is used for reset, and one switched excitation channel is used for clock (on 725 card with CR7). If a switched excitation port is not available, an additional control port can be used to provide clock pulses to the multiplexer.

#### 4.1.1 Reset

The reset (“RES”) line is used to activate the AM16/32A. A signal in the range of +3.5 to +16 VDC applied to the reset terminal activates the multiplexer. When this line drops lower than +0.9 VDC, the multiplexer enters a quiescent, low-current-drain state. In the quiescent state the common (“COM”) terminals are electrically disconnected from all of the sensor input channels. Reset should always connect to a datalogger control port. Instruction 86 (option code 41 - 48 to activate, and 51 - 58 to deactivate) is generally used to activate/deactivate the multiplexer, however, in the case of the 21X or CR7 with older PROMS, Instruction 20 is commonly used. The CR800, CR850, CR3000, CR5000, and CR1000 uses the PortSet instruction to control the reset line.

#### 4.1.2 Clock

Pulsing the AM16/32A “CLK” line high (“RES” line already high) advances the channel. When reset first goes high, the common terminals ODD H, ODD L and EVEN H, EVEN L are disconnected from all sensor input terminals. With the panel switch in “4x16” mode, when the first clock pulse arrives the “COM” terminals are switched to connect with sensor input channel 1 (blue lettering) consisting of 1H, 1L, 2H, and 2L. When a second clock pulse arrives the common lines are switched to connect to channel 2 (3H, 3L, 4H, 4L). The multiplexer advances on the leading edge of the positive going clock pulse. The voltage level must fall below 1.5 VDC and then rise above 3.5 VDC to clock the multiplexer. The CLK pulse should be at least 1 ms long. A delay (typically 10 to 20 ms) is inserted between the beginning of the CLK pulse and the measurement instruction to ensure sufficient settling time for relay contacts.

With the 21X and CR7 dataloggers, switched excitation is generally used to clock the multiplexer (Instruction 22 configured for 5000 mV excitation). If no switched excitation channel is available, it is possible to clock using control ports. See Section 5.1 for details.

In the case of the CR5000, CR3000, CR800, CR850, CR1000, CR23X, and CR10(X), a control port is generally used to clock the multiplexer. Instruction 86 with the pulse port option (command code 71 through 78) generates a 10 ms pulse which works well.

The CR5000, CR3000, CR800, CR850, and CR1000 uses a control port controlled by PortSet, Delay, and SubScan/NextSubScan to create the Clock pulses (see program example in Section 5.3).

If several multiplexers are required, a CR5000, CR3000, CR800, CR850, CR1000, CR10(X) or CR23X control port can source sufficient current to drive up to six AM16/32A CLK or RES inputs wired in parallel.

### 4.1.3 Ground

The AM16/32A has a ground lug that should be connected to earth ground via an 8 AWG wire. This connection should be as short as possible.

The AM16/32A “GND” terminal is connected to datalogger power ground. The AM16/32A “GND” terminal is also connected to the MUXPOWER cable (or equivalent) SHIELD and, via that, to datalogger power ground (see Figure 3). If a separate power supply is used, the AM16/32A ground should also connect to the separate supply’s ground (Figure 4). An AM16/32A “COM $\frac{1}{2}$ ” terminal should connect to a datalogger ground terminal (“ $\frac{1}{2}$ ” or “G”) via the MUXSIGNAL cable (or equivalent) also according to Figure 5 (see 4.2.1). The datalogger itself must connect to earth ground by one of the methods described in the Installation and Maintenance Section of your datalogger operator’s manual.

### 4.1.4 Power Supply

The AM16/32A requires a continuous 12 VDC power supply for operation. The multiplexer's current drain is less than 210 microamps in the quiescent state and is typically 6 to 11 milliamps at 12 VDC when active (see current drain spec). The power supply is connected to the multiplexer terminals labeled “12V” (+) and “GND”. Connect the “GND” wire first for safety.

In many applications it is convenient to power the AM16/32A from a datalogger battery. For more power-intensive applications, an external, rechargeable, 12 VDC, 60 Amp Hr source may be advisable. Lead-acid supplies are recommended where solar or AC charging sources are available because they handle well being “topped off” by constant charging. The BPALK alkaline supply (12 Amp Hr) can be used to power the AM16/32A in applications where the average system current is low, or where it is convenient to frequently replace batteries. It is advisable to calculate the total power requirements of a system and the expected longevity of the power supply based on average system current drains (e.g. logger, multiplexer, other peripherals and sensors) at the expected ambient temperatures.

The average power required to operate an AM16/32A depends on the percentage of time it is active per time period. For example, if a CR10X makes differential measurements on 32 thermocouples every minute, the average current drain due to the AM16/32A would be about  $((.030 \text{ Sec/chan} \times 32 \text{ chan})/60 \text{ Sec}) \times 6 \text{ mA} = 0.1 \text{ mA}$ . Under the same conditions, a 2 second execution interval rate increases the average system current drain to about  $((.030 \text{ Sec/chan} \times 32 \text{ chan})/2 \text{ Sec}) \times 6 \text{ mA} = 2.9 \text{ mA}$ . At a minimum, the power supply must be able to sustain the system between site visits anticipating the worst environmental extremes.

If a 21X power supply is used to power the AM16/32A, all low-level analog measurements (thermocouples, pyranometers, thermopiles, etc.) must be made differentially. Differential measurements are required because slight ground potentials are created along the 21X analog terminal strip when the 12V supply is used to power peripherals. This limitation reduces the number of available analog input channels and may mandate the use of an external supply for the AM16/32A (Figure 4).

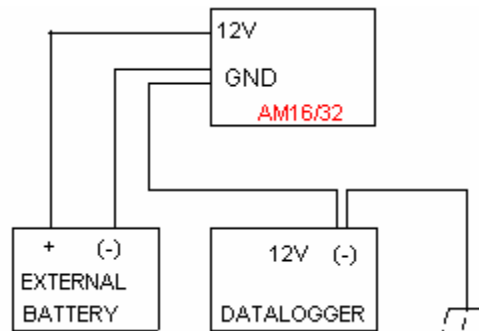

FIGURE 4. Power and Ground Connections for External Power Supply.

Low supply voltage and high ambient temperatures affect the actuation time of the multiplexer relays (Figure 2). If your program does not allow the relay contacts sufficient time to close before a measurement is started, the result will be inaccurate or overranged values.

## 4.2 Measurement Terminals

Most of the terminals on the AM16/32A are dedicated to the connection of sensors to the multiplexer (Figure 1). Depending on the panel switch selection (“4x16” or “2x32” mode), the sensor input terminals are organized into 16 groups (blue letters) of 4 sensor inputs or 32 groups (white letters) of 2 sensor inputs. The terminals accept solid or tinned, stripped sensor leads. The four “COM” terminals marked “ODD H, L” and “EVEN H, L” located by the mode switch provide for attachment of the common signal leads that carry multiplexed sensor signals to the datalogger.

### 4.2.1 COM Terminals

The four terminals dedicated to multiplexer-datalogger connection are located under the blue “COM” next to the mode switch. The terminals are labeled: ODD H, ODD L, EVEN H, and EVEN L. In “4x16” mode the AM16/32A maintains the four “COM” terminals electrically isolated from one another. In “2x32” mode the AM16/32A maintains an internal connection between ODD H and EVEN H and between ODD L and EVEN L.

Common “ $\perp$ ” terminals are provided next to the COM ODD and COM EVEN terminals. They bus internally to the other thirty-two “ $\perp$ ” terminals on the AM16/32A and are connected at all times (i.e., not switched). Their function is to provide a path to ground for sensor cable shields. A “COM $\perp$ ” terminal should be wired to datalogger ground via the MUXSIGNAL cable (or equivalent) shield according to the following table.

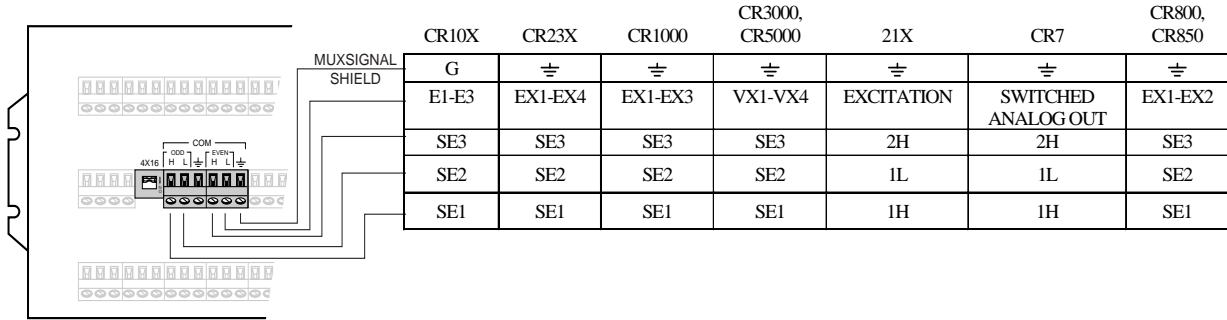

FIGURE 5. Typical AM16/32A to Datalogger Signal Hookup (4x16 Mode)

### 4.2.2 Sensor Input Terminals

The terminals for sensor attachment are divided into 16 groups (panel switch set to “4x16”) or into 32 groups (panel switch set to “2x32”). The groups consist of four or two Simultaneously Enabled Terminals (SETs). With panel switch set to “4x16” mode the blue channel numbers apply. The SETs are numbered starting at 1 (1H, 1L, 2H, 2L) and continuing until SET 16 (31H, 31L, 32H, 32L).

In “4x16” mode the odd numbered terminals (example: 5H, 5L) are relay switched to the COM ODD terminals while the even terminals (6H, 6L) are switched to the COM EVEN terminals. When activated by the RES line being high, as the AM16/32A receives clock pulses from the datalogger, each SET of four in turn is switched into contact with the four COM terminals. For example, when the first clock pulse is received from the datalogger, SET 1 (1H, 1L, 2H, 2L) are connected with COM (ODD H, ODD L, EVEN H, EVEN L) terminals respectively. When the second clock pulse is received, the first SET is switched out (channel 1 sensor inputs become open circuits) and SET 2 (3H, 3L, 4H, 4L) are connected to the four COM terminals. A given SET will typically be connected to the common terminals for 20 ms.

With panel switch set to “2x32” mode the white channel numbers apply. The SETs are labeled beginning with 1H, 1L and ending with 32H, 32L. In “2x32” mode when the AM16/32A selects a given channel the “H” sensor terminal is relay connected to both COM “H” terminals and the “L” sensor terminal is connected to both COM “L” terminals (COM ODD H connects to COM EVEN H and COM ODD L connects to COM EVEN L when panel switch is in “2x32” mode).

## 5. Datalogger Programming

A good way for the beginner or veteran datalogger programmer to create an AM16/32A program is to obtain a copy of SCWIN (Short Cut Program Builder for Windows). It can be downloaded free of charge from the Campbell Scientific web site (<http://www.campbellsci.com>). SCWIN can build many program configurations for various supported sensors providing a quick way to generate an application program.

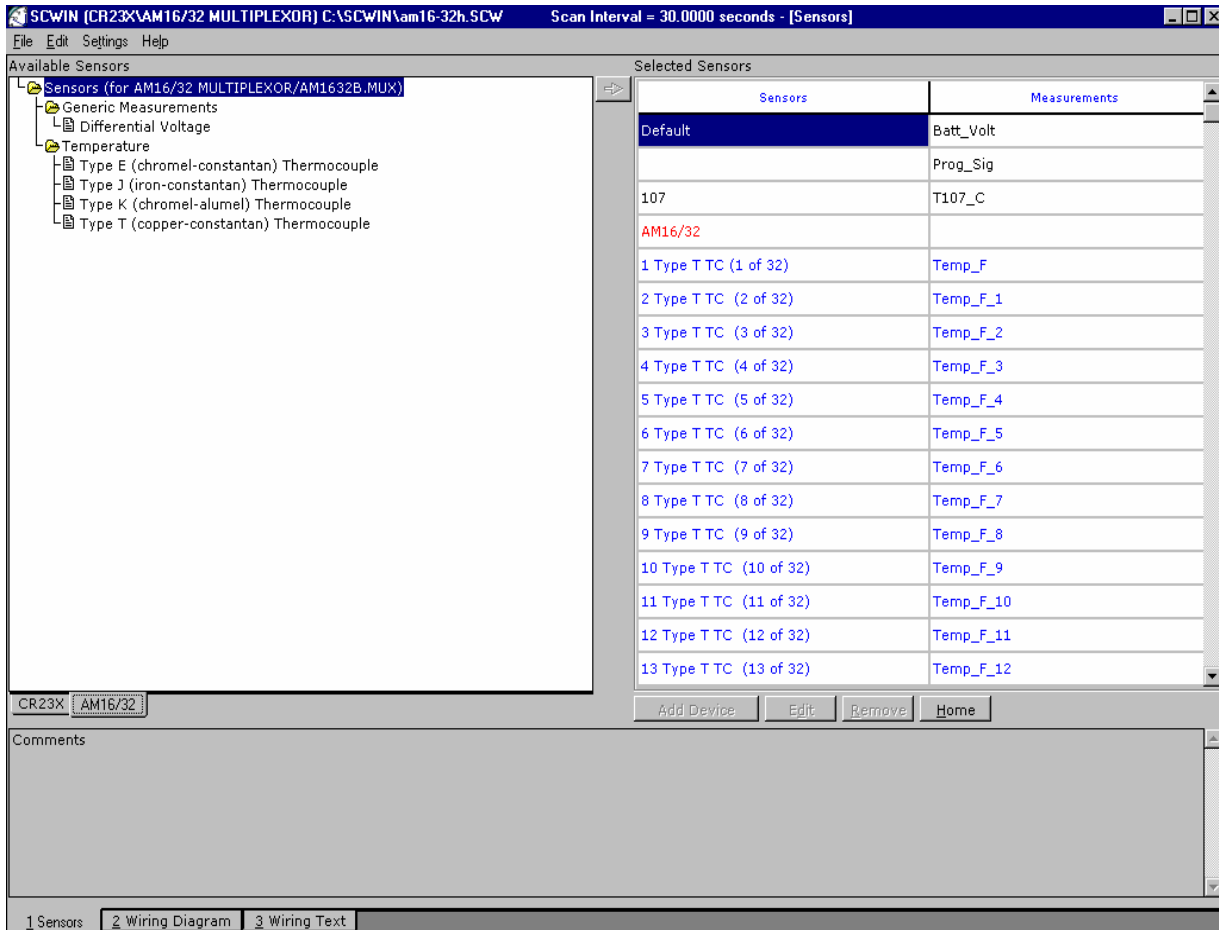

FIGURE 6. SCWIN (Short Cut for Windows Program Builder)



## 5.1 Single Loop Instruction Sequence

When a number of similar sensors are multiplexed and measured, the Instructions to clock the AM16/32A and to measure the sensors are placed within a program loop. For the CR23X, CR10(X), 21X, and CR7, the generalized structure of a program loop is as follows:

**TABLE 2. Single Loop Instruction Sequence**

#	INSTRUCTION FUNCTION
1	Set port high to activate AM16/32A
2	Begin loop
3	Clock AM16/32A & delay
4	Step loop index (required in some configurations)
5	Measure sensor
6	Additional processing
7	End loop
8	Additional program loops
9	Set port low to deactivate AM16/32A

#1, #9 Activate/deactivate the AM16/32A –The control port connected to reset (RES) is set high to activate the AM16/32A prior to the advance and measure sequence and set low following the measurement loop(s). For the CR10X, CR23X, and CR10, 21X, CR7 dataloggers with OS series PROMs, use instruction 86 to set and reset the port (for CR10, 21X, and CR7 with earlier PROMs, use Instruction 20).

#2, #7 Begin and End a Loop – For the CR23X, CR10(X), 21X, and CR7 dataloggers, a loop is defined by Instruction 87 (Begin Loop), and by Instruction 95 (End). Within Instruction 87, the 2nd parameter (iteration count) defines the number of times the instructions within the loop are executed before the program exits the loop.

# 3 Clock and Delay – With the CR23X and CR10(X) the clock line is connected to a control port. Instruction 86 with the pulse port command (71-78) pulses the clock line high for 10 ms. Instruction 22 can be added following the P86 to delay an additional 10 ms.

When using a 21X or CR7, the clock line may be connected to either an excitation or control port. Connection to an excitation port is preferred because only one instruction (22) is required to send the clock pulse. Instruction 22 should be configured to provide a 10ms delay with 5000 mV of excitation. A control port can be used to clock the AM16/32A if an excitation port is not available. The 21X and CR7 instruction sequence required to clock with a control port is: Instruction 20 (set port high), Instruction 22 (delay 20 ms without excitation), followed by Instruction 20 (set port low).

# 4 Step Loop Index – With the CR23X, CR10(X), 21X or CR7, the Step Loop Index instruction “90” is used when a measurement instruction within a loop has more than one repetition. This instruction allows 2 - 4 sensors per SET to be measured by 2 – 4 analog input channels. The Step Loop Index instruction sends each measurement value to a sequentially assigned input location without overwriting any other current iteration value. Without this instruction, the input location within the loop will advance by *only one location per loop iteration* even though the measurement instruction’s Input Location is indexed.

Example: 2 sensors per SET, 6 sensors total; two reps specified in measurement instruction; two measurement values assigned to indexed input locations (--); P90 step of 2. Loop count of three.

	Input locations					
	1	2	3	4	5	6
First pass:	1	2				
Second pass:			3	4		sensor
Third pass:					5	6 numbers

Removing the step loop instruction from the program, the following situation results:

	Input Locations					
	1	2	3	4	5	6
First pass:	1	2				
Second pass:			3	4		sensor
Third pass:					5	6 numbers

Without P90 the measurement values for the 2nd and 4th sensors will be overwritten in their input locations. The 1st, 3rd, 5th, and 6th measurement values will reside in the first 4 input locations.

Step Loop Instruction “90” is available in the CR23X, CR10(X), CR7, and 21X (with 3<sup>rd</sup> PROM). For 21X dataloggers without 3<sup>rd</sup> PROM (i.e., no Instruction 90), a separate measurement instruction (with one rep) is required for each sensor measured within the loop. The input location parameter within both measurement instructions is indexed.

For example: 2 sensors per SET; one rep in each of two measurement instructions; two measurement values assigned to indexed input locations (--), one begins with input location 1, the other with input location 4; no P90. A total of six sensors to be measured; loop count is three.

	Input locations					
	1	2	3	4	5	6
First pass:	1			2		
Second pass:			3		4	sensor
Third pass:				5		6 numbers

A potential drawback of this technique is that sequential sensors (i.e., those input to the same SET) will not have sequential input locations.

#5 Measure - Enter the instruction needed to measure the sensor(s) (see Section 6, Sensor Hook-Up & Measurement Examples). The input location parameter of a measurement instruction is indexed if a (--) appears to the right of the input location. Index an input location by pressing "C" after keying the location or by pressing F4 in Edlog while cursor is on the input location parameter. Indexing causes the input location to be incremented by 1 with each pass through the loop. This allows the measurement value to be stored in sequential input locations. Instruction 90, as explained above, allows the indexed input location to be incremented in integer steps greater than 1.

**NOTE**

---

If more than the datalogger's default number of input locations are required, then additional input locations must be assigned using the datalogger \*A mode. Consult your datalogger manual for details.

---

#6 Optional Processing - Additional processing is sometimes required to convert the reading to the desired units. It may be more efficient if this processing is done outside the measurement loop. A second loop can be used for processing, if necessary.

**GENERALIZED "4x16" MODE PROGRAM LOOPS FOR THE CR23X, CR10(X), 21X, and CR7**

<u>21X SAMPLE PROGRAM</u>	<u>CR7 SAMPLE PROGRAM</u>	<u>CR10X, CR23X SAMPLE PGM</u>
* 1 Table 1 Programs	* 1 Table 1 Programs	* 1 Table 1 Programs
01: 60 Sec. Execution Interval	01: 60 Sec. Execution Interval	01: 60 Sec. Execution Interval
:ACTIVATE MULTIPLEXER	:ACTIVATE MULTIPLEXER	:ACTIVATE MULTIPLEXER
1: Set Port (P20)	1: Set Port (P20)	1: Do (P86)
1: 1 Set high	1: 1 Set high	1: 41 Set high
2: 1 Port Number	2: 1 EX Card	Port 1
2: Excitation with Delay (P22)	2: Excitation with Delay (P22)	2: Excitation with Delay (P22)
1: 1 Ex Channel	1: 1 Ex Channel	1: 1 Ex Channel
2: 0 Delay w/Ex (0.01 sec units)	2: 0 Delay w/Ex (0.01 sec units)	2: 0 Delay w/Ex (0.01 sec units)
3: 15 Delay after Ex (0.01 sec units)	3: 15 Delay after Ex (0.01 sec units)	3: 15 Delay after Ex (0.01 sec units)
4: 0 mV Excitation	4: 0 mV Excitation	4: 0 mV Excitation
:BEGIN MEASUREMENT	:BEGIN MEASUREMENT	:BEGIN MEASUREMENT
:LOOP	:LOOP	:LOOP
3: Beginning of Loop (P87)	3: Beginning of Loop (P87)	3: Beginning of Loop (P87)
1: 0 Delay	1: 0 Delay	1: 0 Delay
2: 16 Loop Count	2: 16 Loop Count	2: 16 Loop Count
:CLOCK PULSE AND DELAY	:CLOCK PULSE AND DELAY	:CLOCK PULSE
4: Excitation with Delay (P22)	4: Excitation with Delay (P22)	4: Do (P86)
1: 1 EX Chan	1: 1 EX Card	1: 72 Pulse Port
2: 1 Delay w/EX (units=.01 sec)	2: 2 EX Chan	2
3: 1 Delay after EX (units=.01 sec)	3: 1 Delay w/EX (units=.01 sec)	:DELAY
4: 5000 mV Excitation	4: 1 Delay after EX (units=.01 sec)	5: Excitation with Delay (P22)
5: User Specified Measurement Instruction	5: 5000 mV Excitation	1: 1 EX Chan
:END MEASUREMENT	5: User Specified Measurement Instruction	2: 0 Delay w/EX
:LOOP	:END MEASUREMENT	3: 1 Delay after EX
6: End (P95)	:LOOP	4: 0 mV Excitation
:DEACTIVATE MULTIPLEXER	6: End (P95)	6: User Specified Measurement Instruction
7: Set Port (P20)	:DEACTIVATE MULTIPLEXER	:END MEASUREMENT
1: 0 Set low	7: Set Port (P20)	:LOOP
2: 1 Port Number	1: 0 Set low	7: End (P95)
	2: 1 EX Card	:DEACTIVATE MULTIPLEXER
	3: 1 Port No.	8: Do (P86)
		01: 51 Set low
		Port 1

FIGURE 7. Example "4x16" Mode Program Loops for CR23X, CR10(X), 21X and CR7 Loggers

**EXAMPLE "2x32" MODE PROGRAMS - GENERALIZED PROGRAM LOOPS FOR THE CR23X, 21X, CR10(X), AND CR7.**

<u>21X SAMPLE PROGRAM</u>			<u>CR7 SAMPLE PROGRAM</u>			<u>CR10(X), CR23X SAMPLE PROGRAM</u>		
*	1	Table 1	*	1	Table 1	*	1	Table 1
01:	60	Programs Sec. Execution Interval	01:	60	Programs Sec. Execution Interval	01:	60	Programs Sec. Execution Interval
;ACTIVATE MULTIPLEXER			;ACTIVATE MULTIPLEXER			;ACTIVATE MULTIPLEXER		
1: Set Port (P20)			1: Set Port (P20)			1: Do (P86)		
1:	1	Set high	1:	1	Set high	1:	41	Set high
2:	1	Port Number	2:	1	EX Card			Port 1
2: Excitation with Delay (P22)			2: Excitation with Delay (P22)			2: Excitation with Delay (P22)		
1:	1	Ex Channel	1:	1	Ex Channel	1:	1	Ex Channel
2:	0	Delay w/Ex (0.01 sec units)	2:	0	Delay w/Ex (0.01 sec units)	2:	0	Delay w/Ex (0.01 sec units)
3:	15	Delay after Ex (0.01 sec units)	3:	15	Delay after Ex (0.01 sec units)	3:	15	Delay after Ex (0.01 sec units)
4:	0	mV Excitation	4:	0	mV Excitation	4:	0	mV Excitation
;BEGIN MEASUREMENT			;BEGIN MEASUREMENT			;BEGIN MEASUREMENT		
;LOOP			;LOOP			;LOOP		
3: Beginning of Loop (P87)			3: Beginning of Loop (P87)			3: Beginning of Loop (P87)		
1:	0	Delay	1:	0	Delay	1:	0	Delay
2:	32	Loop Count	2:	32	Loop Count	2:	32	Loop Count
CLOCK PULSE/DELAY			;CLOCK PULSE/DELAY			;CLOCK PULSE		
4: Excitation with delay (P22)			4: Excitation with delay (P22)			4: Do (P86)		
1:	1	EX Chan	1:	1	EX Chan	1:	72	Pulse Port 2
2:	1	Delay w/EX (units= .01 sec)	2:	2	EX Chan	;DELAY		
3:	1	Delay after EX (units= .01 sec)	3:	1	Delay w/EX (units= .01 sec)	5: Excitation with Delay (P22)		
4:	5000	mV Excitation	4:	1	Delay after EX (units = .01 sec)	1:	1	EX Chan
5: User Specified Measurement Instruction			5:	5000	mV Excitation	2:	0	Delay w/EX (units=.01 sec)
;END MEASUREMENT			5: User Specified Measurement Instruction			3:	1	Delay after EX (units=.01 sec)
;LOOP			;END MEASUREMENT			0:	0	mV Excitation
6: End (P95)			;LOOP			6: User Specified Measurement Instruction		
;DEACTIVATE			6: End (P95)			;END MEASUREMENT		
;MULTIPLEXER			;DEACTIVATE			;LOOP		
7: Set Port (P20)			;MULTIPLEXER			7: End (P95)		
1:	0	Set low	7: Set Port P20			;DEACTIVATE		
2:	1	Port Number	1:	0	Set low	;MULTIPLEXER		
			2:	1	EX Card	8: Do (P86)		
			3:	1	Port No.	1:	51	Set low Port 1

FIGURE 8. Example "2x32" Mode Program Loops for CR23X, CR10(X), 21X and CR7 Loggers

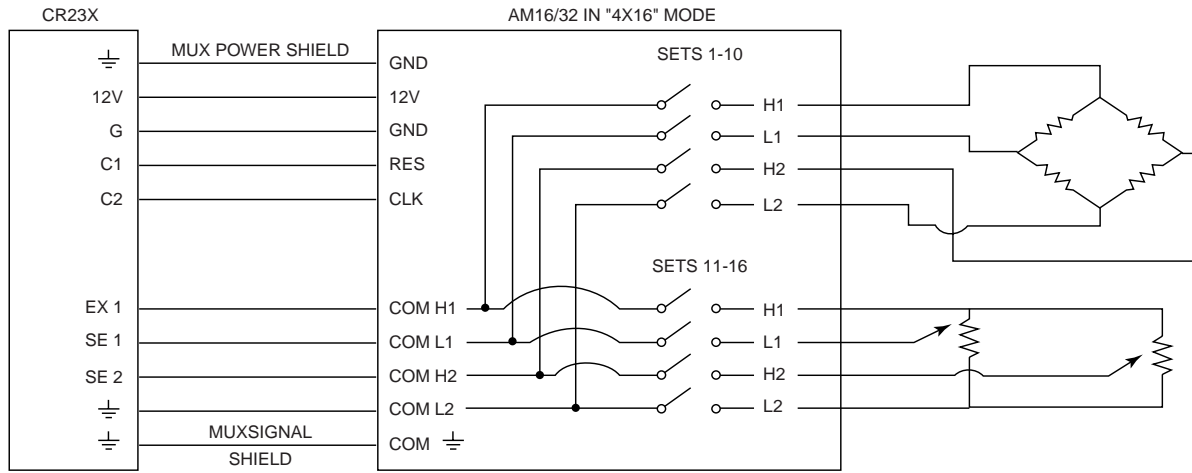

FIGURE 9. Wiring Diagram for Strain Gages and Potentiometers

#8 Additional Loops - Additional loops may be used if sensors that require different measurement instructions are connected to the same multiplexer. In this instance, like sensors are assigned to sequential input SETS. Each group of sensors is measured in a separate loop (steps 2 through 7, Table 2). Each loop contains clock and measurement instructions, and all loops must reside between the instructions that activate and deactivate the AM16/32A (Steps 1 and 9).

The instruction sequence for control of an AM16/32A is given on the following page. The program format is a product of Edlog a datalogger program editor contained in CSI's PC208W Datalogger Support Software.

## 5.2 Multiple Loop Instruction Sequence

As shown above, the programs for operation of the AM16/32A are essentially the same for all CSI dataloggers. To measure sensors of different types, different measurement instructions may be used within successive program loops. In the following example, each loop is terminated with Instruction 95, and the multiplexer is not reset between loops. The example demonstrates the measurement of two dissimilar sensor types (i.e. strain gages and potentiometers).

The program and accompanying wiring diagram are intended as examples only; users will find it necessary to modify both for specific applications.

```

*1 Table 1 Programs
  1: 60          Sec. Execution Interval

;ACTIVATES MULTIPLEXER
1: Do (P86)
  1: 41          Set high Port 1

2: Excitation with Delay (P22)
  1: 1          Ex Channel
  2: 0          Delay w/Ex (0.01 sec units)
  3: 15         Delay after Ex (0.01 sec units)
  4: 0          mV Excitation

;BEGINS STRAIN GAGE MEASUREMENT LOOP
3: Beginning of Loop (P87)
  1: 0          Delay
  2: 10         Loop Count

;CLOCK PULSE
4: Do (P86)
  1: 72         Pulse Port 2

;DELAY
5: Excitation with Delay (P22)
  1: 1          EX Chan
  2: 0          Delay w/EX (units=.01sec)
  3: 1          Delay after EX (units=.01sec)
  4: 0          mV Excitation

;FULL BRIDGE MEASUREMENT INSTRUCTION
6: Full Bridge (P6)
  1: 1          Rep
  2: 3          50 mV slow Range
  3: 1          IN Chan
  4: 1          Excite all reps w/Enchain 1
  5: 5000       mV Excitation
  6: 1--        Loc [:STRAIN #1]
  7: 1          Mult
  8: 0          Offset

;END OF STRAIN GAGE MEASUREMENT LOOP
7: End (P95)

;BEGINNING OF POTENTIOMETER MEASUREMENT LOOP
8: Beginning of Loop (P87)
  1: 0          Delay
  2: 6          Loop Count

9: Step Loop Index (Extended) (P90)
  1: 2          Step

;CLOCK PULSE
10: Do (P86)
  1: 72         Pulse Port 2

```

```

;DELAY
11: Excitation with Delay (P22)
  1: 1      EX Chan
  2: 0      Delay w/EX (units=.01sec)
  3: 1      Delay after EX (units=.01sec)
  4: 0      mV Excitation

;POT. MEASUREMENT INSTRUCTION
12: Excite,Delay,Volt(SE) (P4)
  1: 2      Reps
  2: 5      5000 mV slow Range
  3: 1      IN Chan
  4: 2      Excite all reps w/EXchan 2
  5: 1      Delay (units .01sec)
  6: 5000   mV Excitation
  7: 11--   Loc [:POT #1 ]
  8: 1      Mult
  9: 0      Offset

;END POT. MEASUREMENT LOOP
13: End (P95)

;DISABLES MULTIPLEXER
14: Do (P86)
  1: 40     Reset Low Port 1

15: End Table 1 (P95)

INPUT LOCATION LABELS:
1:STRAIN #1 13:POT #3
2:STRAIN #2 14:POT #4
3:STRAIN #3 15:POT #5
4:STRAIN #4 16:POT #6
5:STRAIN #5 17:POT #7
6:STRAIN #6 18:POT #8
7:STRAIN #7 19:POT #9
8:STRAIN #8 20:POT #10
9:STRAIN #9 21:POT #11
10:STRAIN#1022:POT #12
11:POT #1    23:_____
12:POT #2    24:_____

```

### 5.3 CRBasic Programming

The CR5000, CR800, CR850, CR3000, and CR1000 are programmed with CRBasic; for details see the datalogger manual. While the instructions look different than those used to program the older CR10X, CR23X, etc., they perform similar functions. One difference that needs to be pointed out is that with CRBasic measurement results are stored in a variable array, not numbered input locations. In the older loggers the destination location is “indexed” so that each pass through the measurement loop the result is stored in a higher numbered location. In CRBasic the program must specifically increment an index variable and use that variable to determine where each measurement is stored.



```

GENERALIZED CRBASIC PROGRAMMING SEQUENCE:
ACTIVATE MULTIPLEXER/RESET INDEX
    Portset (1 ,1)      'Set C1 high to Enable Multiplexer
    I=0
BEGIN MEASUREMENT LOOP
    SubScan(0,sec,16)
CLOCK PULSE AND DELAY
    Portset (2,1 )     'Set port 2 high
    Delay (0,20,mSec)
    Portset (2,0)      'Set port 2 low
INCREMENT INDEX AND MEASURE
    I=I+1
    'User specified measurement instruction
    'Storing results in Variable(I)
END MEASUREMENT LOOP
    NextSubScan
DEACTIVATE MULTIPLEXER
    Portset (1 ,0)      'Set C1 Low to disable Multiplexer
    
```

In addition to precision voltage excitation, the CR5000 and CR3000 have programmable current excitation. Current excitation allows a resistance measurement on a four-wire sensor (e.g., a PRT) such as shown in Figure 14 using only a single differential channel and no fixed resistor; the excitation return goes directly to ground. With the current excitation the resistance of the relays and lead wire do not affect the measurement.

### 5.3.1 CR5000 and CR3000 Programming

Although the following example is a CR5000 program, a similar program can be used for the CR3000. This CR5000 program uses the AM16/32A to measure 16 100 ohm Platinum Resistance Thermometers connected in the 4x16 configuration. The program also measures 6 copper constantan thermocouples.

CR5000	AM16/32A		PRT(4 Wires)
	Control/Common	Sensor Terminals	
C1	Reset	Odd H	Excitation
C2	Clock	Odd L	Excitation Return
IX1	COM Odd H	Even H	Sense wire excitation side
IXR	COM Odd L	Even L	Sense wire return side
7H	COM Even H		
7L	COM Even L		

'CR5000 Example Program to measure 16 100 ohm Platinum Resistance Thermometers 'connected to an AM16/32A multiplexer used in the 4x16 configuration. The program also 'measures 6 copper constantan 'thermocouples.

'The Thermocouples are connected to differential channels 1-6.

'Declare Variables:

Public TRef, TCTemp(6), PRTResist(16), PRTTemp(16)

Dim I 'Counter for setting Array element to correct value for mux measurement

'Declare Output Table for 15 minute averages:

DataTable (Avg15Min,1,-1)

DataInterval (0,5,Min,10)

Average (1,TRef,IIEEE4,0)

Average (6,TCTemp(),IIEEE4,0)

Average (16,PRTTemp(),IIEEE4,0)

EndTable

BeginProg

Scan (60,Sec,3,0)

PanelTemp (TRef,250)

TCDiff (TCTemp(),6,mV20C ,1,TypeT,TRef,True ,0,250,1.0,0)

Portset (1 ,1) 'Set C1 high to Enable Multiplexer

Delay (0,150,mSec)

I=0

SubScan(0,sec,16)

'Pulse C2 (Set High, Delay, Set Low) to clock multiplexer

Portset (2,1 )

Delay (0,20,mSec)

Portset (2,0)

I=I+1

'The Resistance measurement measures the PRT resistance:

Resistance (PRTResist(I),1,mV50,7,Ix1,1,500,True ,True ,0,250,0.01,0)

'With a multiplier of 0.01 (1/100) the value returned is R/Ro (Resist/Resist @ 0 deg)

'the required input for the PRT temperature calculation instruction.

NextSubScan

Portset (1 ,0) 'Set C1 Low to disable Multiplexer

'Calculate the Temperature from R/Ro:

PRT (PRTTemp(1),16,PRTResist(1),1.0,0)

CallTable Avg15Min 'Call the DataTable

NextScan

EndProg

### 5.3.2 CR1000, CR800, and CR850 Programming

Although the following example is a CR1000 program, a similar program can be used for the CR800 or CR850. This CR1000 program uses the AM16/32A to measure 48 CS616 probes connected in the 4x16 configuration. The program also measures datalogger battery voltage and temperature.

Wiring for CR1000 Program Example			
CR1000	AM16/32A (4x16)		CS616*
	Control/Common	Sensor Terminals	
C4	RES	Odd H	CS616#1_Green
C5	CLK	Odd L	CS616#2_Green
12 V	12 V	Gnd	#1,2,3_Blk & Clear
Gnd	Gnd	Even H	CS616#3_Green
1H	COM Odd H	Even L	#1,2,3_Orange
1L	COM Odd L		
Gnd	Gnd		
2H	COM Even H		
C6	COM Even L		

\*Three sensors to each set of AM16/32A terminals.

### CR1000 Program Example

```

'Declare Public & Dim Variables
Public batt_volt
Public Panel_temp
Public Period(48)
Public VWC(48)
Public Flag(1)
Dim I

'Declare Constants
'CS616 Default Calibration Constants
const a0= -0.0663
const a1= -0.0063
const a2= 0.0007
'Flag logic constants
const high = true
const low = false

'Define Data Tables
DataTable (Dat30min,1,-1)
    DataInterval (0,30,Min,10)
    Minimum (1,batt_volt,FP2,0,False)
    Average (1,Panel_temp,FP2,0)
    Sample (48,Period(),FP2)
    Sample (48,VWC(),FP2)
EndTable

'Main Program
BeginProg
    Scan (5,Sec,0,0)                'scan instructions every 5 sec
        Battery (Batt_volt)
        PanelTemp (Panel_temp,250)
    '
    'Set flag 1 High every 30 min (Note: User can manually set flag 1 high/low)
    If IfTime (0,30,min)Then flag (1)=high '++++++++++++++++++++
    If Flag(1)=high Then
        'measure 48ea CS616 probes on AM16/32A in (4x16) mode
        PortSet (4,1) 'Set Mux Reset line High
    '
    Delay (0,150,mSec)

```

```

I=1                                'set sub scan loop counter
SubScan (0,mSec,16)
PulsePort (5,10000)                'Clock Mux
CS616 (Period(I),3,1,6,3,1.0,0)'measure 3ea CS616 probes
I=I+3
NextSubScan
'
For I=1 to 48                       'convert CS616 period to Volumetric Water Content
VWC(I)=a0 + a1*Period(I) + a2*Period(I)^2
Next
'
PortSet (4,0)                       'Set Mux Reset line Low
flag(1)= low
EndIf                                '+++++
'
CallTable Dat30min                  'Call Output Tables
NextScan
EndProg

```

## 5.4 General Programming Considerations

The excitation voltage, integration time, and delay time associated with measuring the signal, and the speed at which the channels are advanced can be varied within the datalogger program. In general, longer delay times are necessary when sensors and datalogger are separated by longer lead lengths. Consult your datalogger manual for additional information on these topics.

## 6. Sensor Hook-up and Measurement Examples

This section covers sensor-to-AM16/32A connections as well as AM16/32A-to-datalogger connections. The following are examples only, and should not be construed as the only way to make a particular measurement. See the Measurement Section of your datalogger manual for more information on basic bridge measurements. Most of the following examples do not depict datalogger-to-AM16/32A control connections (Section 4.1), but their presence is implied and required. Campbell Scientific recommends that only sensor shield (drain) wires be connected to AM16/32A shield terminals labeled (“ $\text{—}$ ”).

### 6.1 Single-Ended Analog Measurement without Sensor Excitation

Sensor to AM16/32A wiring - one single-ended sensor not requiring excitation can be connected to an input SET with panel mode switch set to “2x32”.

Multiplexer to Datalogger wiring - The COM signal line is input to a single-ended analog input channel. The COM signal-ground line is tied to “ $\text{—}$ ” at the CR23X, 21X, or CR7, and to “AG” at the CR10(X). Up to 32 single-ended sensors can be measured by one single-ended datalogger channel in this manner.

**NOTE** Low level single-ended measurements are not recommended in 21X applications where the 21X's internal 12VDC supply is used to power the multiplexer or other peripherals (see Section 4.1.4).

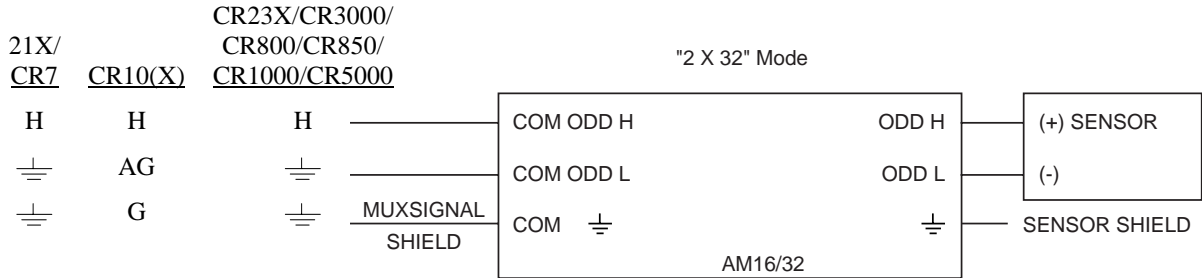

FIGURE 10. Single-ended Measurement without Excitation

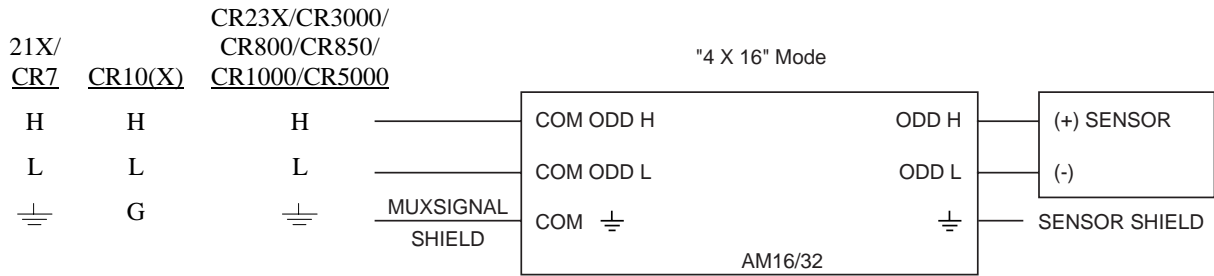

FIGURE 11. Differential Measurement without Excitation

## 6.2 Differential Analog Measurement without Sensor Excitation

Sensor to Multiplexer wiring - Up to two differential sensors that don't require excitation may be connected to one input SET with panel switch set to "4x16" mode. Sensor shields are connected to the input "GND" terminals.

Multiplexer to Datalogger wiring - The two pairs of COM terminals (ODD H, ODD L and EVEN H, EVEN L) are connected to two pairs of differential analog inputs at the datalogger. Observe H to H and L to L from sensor to multiplexer to analog input. In "4x16" mode up to 32 differential sensors can be measured by two differential datalogger channels in this way.

With panel switch set to "2x32" mode, one differential input can measure up to 32 differential sensors in SETs of two with appropriate programming.

### 6.3 Half Bridge Measurements

Measurements of this type may be subdivided into three categories based on completion resistance and the presence or absence of measured excitation. If the sensor's completion resistor(s) are installed at the datalogger panel (example: a CSI 107 probe modified for multiplexer use), then three probes per SET may be excited and measured in "4x16" mode (Figure 12). However, if the circuit is completed within the sensor (e.g. potentiometers), then excitation, wiper signal, and ground must be multiplexed. Because excitation and ground may be multiplexed in common, up to two sensors per SET may be measured (Figure 13). If measured excitation is required (i.e. four wire half-bridge), then only one sensor per SET of four may be measured (Figure 14).

#### 6.3.1 Half Bridge Measurement with Completion Resistor at Datalogger

Sensor to Multiplexer wiring - up to three half bridges may be connected to one input SET in "4x16" mode, provided that the sensors' three completion resistors are located at the datalogger (Figure 12).

Multiplexer to Datalogger wiring - Signal lines from the multiplexer COM terminals tie to three consecutive single-ended analog input channels. Three precision completion resistors connect from analog input channels to analog ground in CR10(X) or to "≡" in the other dataloggers.

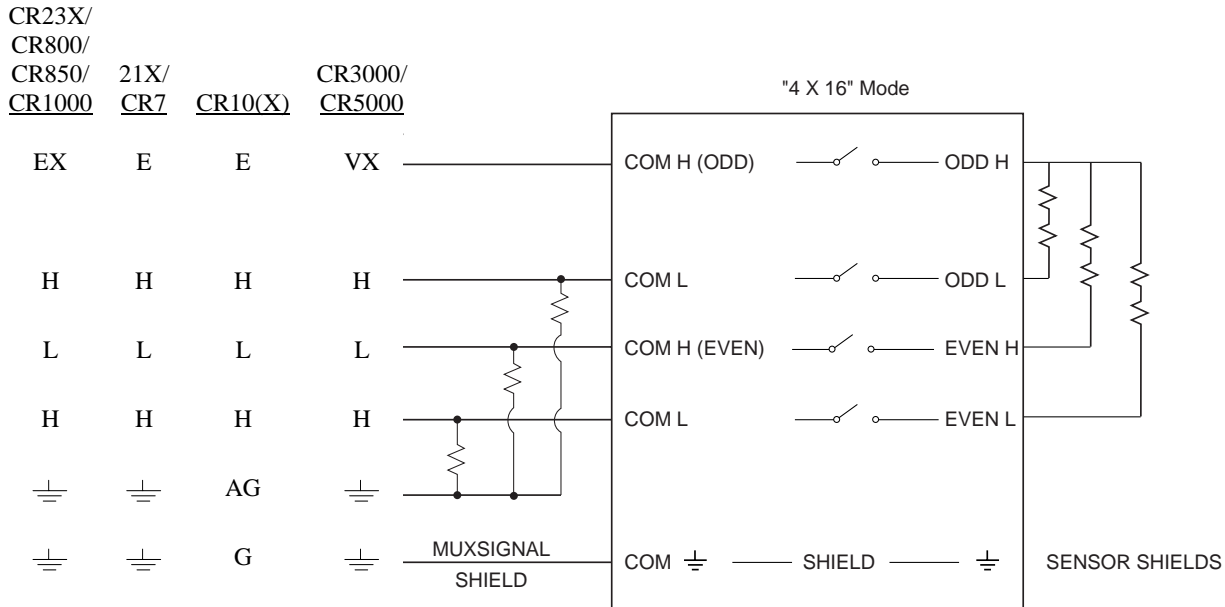

FIGURE 12. Half Bridge (Modified 107 Temperature Probe) Hook-up and Measurement.

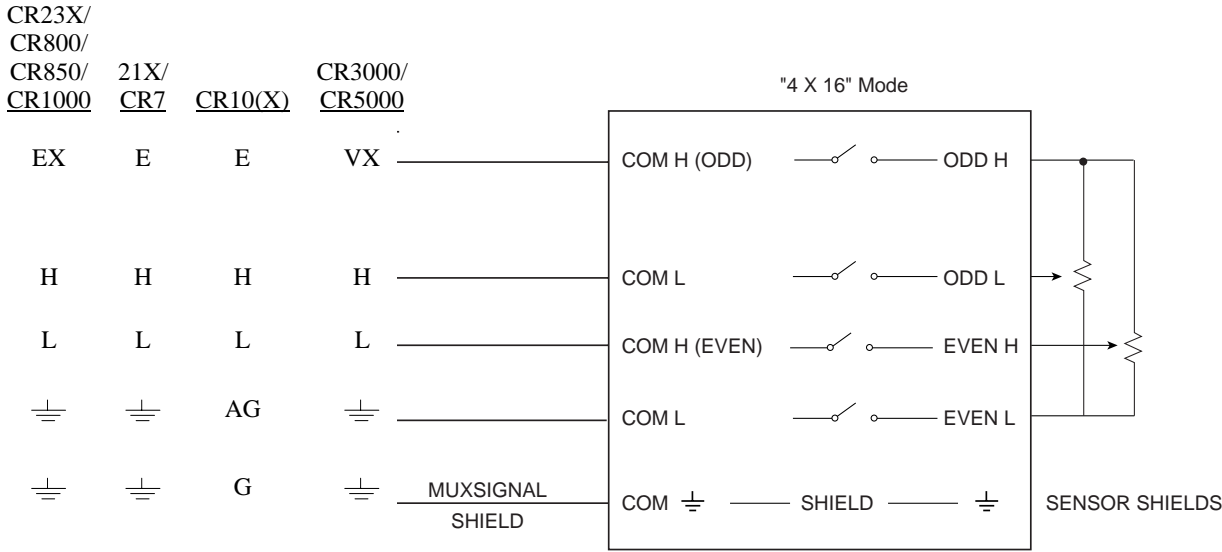

FIGURE 13. Potentiometer Hook-up and Measurement

**6.3.2 Potentiometer Measurement**

Sensor to Multiplexer wiring – if panel switch is set to “4x16” mode, up to two potentiometers may be connected to one input SET. Excitation and ground leads may be common; signal leads must be routed separately (Figure 13).

Multiplexer to Datalogger wiring - Signal lines from two COM terminals are connected to two consecutive single-ended analog input channels. One COM terminal is connected to a datalogger switched excitation channel, and the remaining COM line connects to datalogger ground. Up to 32 potentiometers may be measured by two single-ended datalogger channels.

**6.3.3 Four Wire Half Bridge (Measured Excitation Current)**

Sensor to Multiplexer Wiring - one sensor per input SET. The panel switch is set to “4x16” mode.

Multiplexer to Datalogger Wiring - One COM line is tied to a datalogger excitation channel, and two COM lines to a differential analog input. The remaining COM line is connected to the H side of a datalogger differential channel along with a fixed resistor. The other side of the resistor connects to the L side of the differential channel and to ground (Figure 14). Up to 16 four wire half-bridges may be measured by two differential datalogger channels in this manner.

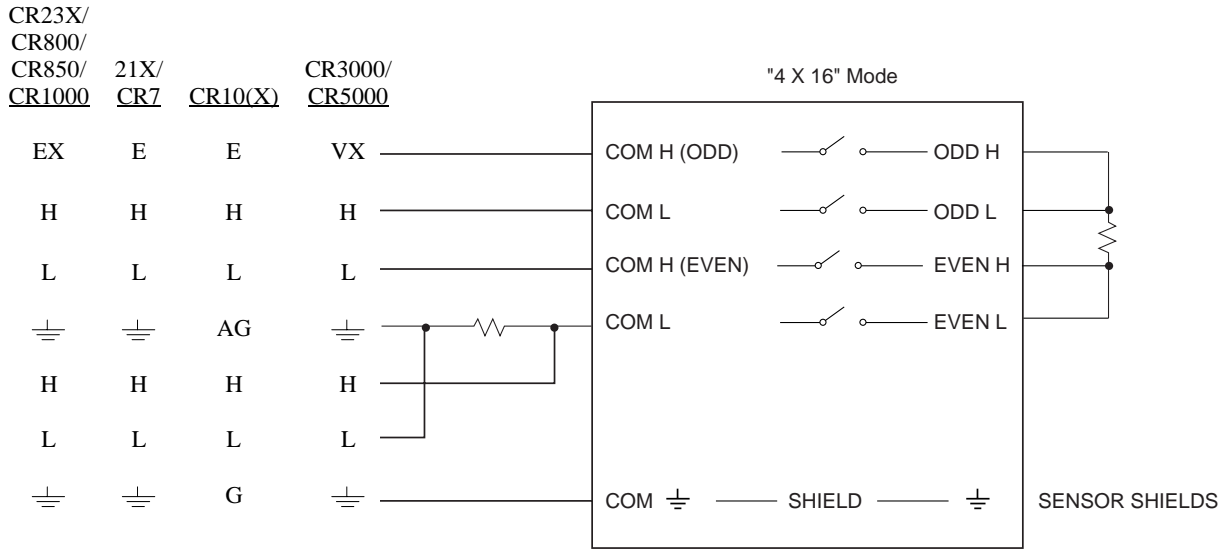

FIGURE 14. Four Wire Half Bridge Hook-up and Measurement

The CR5000 and CR3000 also have current excitation channels which allow a resistance measurement. Because the excitation current is known, it is not necessary to measure the voltage across a fixed resistor to determine the current as in Figure 14. See Section 5.3 for an example.

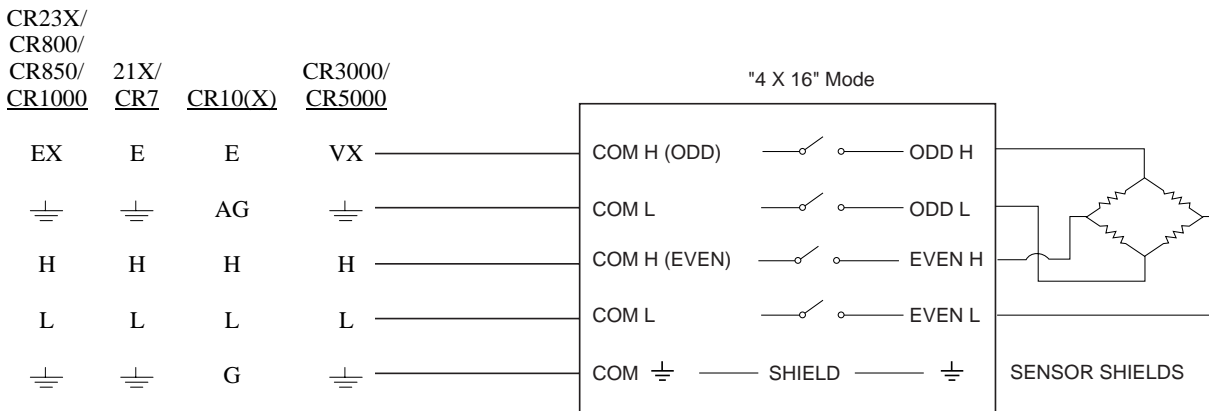

FIGURE 15. Full Bridge Measurement

## 6.4 Full Bridge Measurements

Sensor to Multiplexer wiring – With panel switch set to “4x16” mode, excitation, ground, and the two signal leads may be connected to one input SET (Figure 15).

Multiplexer to Datalogger wiring - COM terminals are connected to a datalogger excitation channel, a differential analog input channel, and an analog ground. Up to sixteen full bridges may be multiplexed through the AM16/32A.



A problem with making full bridge measurements with this configuration is that the resistance of the lead wire and multiplexer relays can cause a voltage drop, reducing the excitation at the bridge. The following section describes a configuration that compensates for this by measuring the excitation at the bridge.

### 6.5 Full Bridges with Excitation Compensation

Sensor to Multiplexer wiring – With panel switch set to "4x16" mode you are 2 lines short for a six wire measurement. One solution is to multiplex the four signal wires through the AM16/32A, but bypass the AM16/32A with excitation and ground wires. This means that the sensors will be excited in parallel which causes a higher current drain, possibly enough to exceed the current available from the datalogger's excitation channel. Alternatively, the excitation and ground leads can be multiplexed through an additional AM16/32A allowing the sensors to be excited one at a time (Figure 16). In this case the 12V, GND, CLK, and RES lines of the second multiplexer are wired in parallel with those of the first, effectively widening the multiplexer to "8x16".

Multiplexer to Datalogger wiring - Four leads from the COM ODD, EVEN terminals connect to two sequential differential analog channels in the datalogger. Excitation and ground are multiplexed by the second AM16/32A. Both multiplexers can be reset and clocked by the same control ports and/or excitation channels to simplify programming.

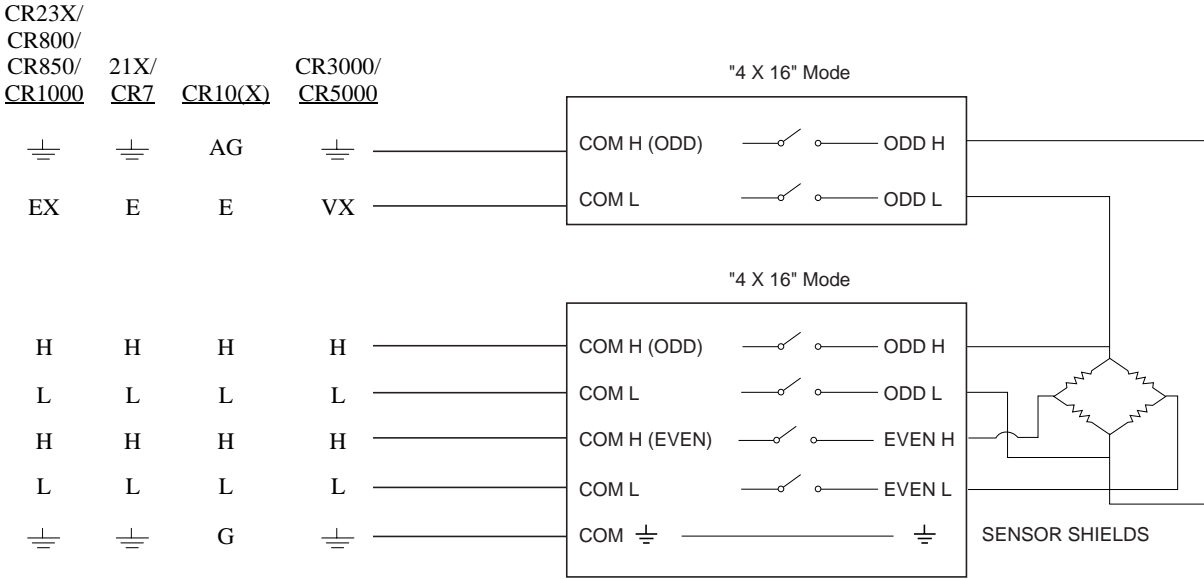

FIGURE 16. Full Bridge Measurement with Excitation Compensation

## 6.6 Thermocouple Measurement

The datalogger manuals contain thorough discussions of thermocouple measurement and error analysis. These topics will not be covered here.

### 6.6.1 Measurement Considerations

**Reference Junction** - As shown in Figure 17 and 18, two reference junction configurations are possible: 1) reference located at the datalogger or 2) reference at the AM16/32A.

**Datalogger Reference** - The CR1000, CR800, CR850, CR3000, CR23X, 21X and the CR7 723-T Analog Input card with RTD have built-in temperature references. The CR10XTCR Thermocouple Reference (not standard with CR10X purchase), is installed on the wiring panel between the two analog input terminal strips.

When the reference junction is located at the datalogger, the signal wires between the data-logger and the AM16/32A must be of the same wire type as the thermocouple (Figure 17). The "polarity" of the thermocouple wires must be maintained on each side of the multiplexer (e.g. if constantan wire is input to an L terminal, then a constantan wire should run between the multiplexer's COM ODD L terminal and the datalogger measurement terminal). Figures 17 and 18 depict type T thermocouple applications, but other thermocouple types (e.g. E, J, and K) may also be measured and linearized by the dataloggers.

If thermocouples are measured with respect to the datalogger reference (i.e. the signal wires between datalogger and AM16/32A are made of thermocouple wire), then it is not recommended that one make measurements of any other sensor type through the AM16/32A. Two problems would arise due to the properties of thermocouple wire:

An extraneous thermocouple voltage would be added to the non-thermocouple signal at the junction of dissimilar metals (e.g. the multiplexer COM terminals). The magnitude of this signal would vary with the temperature difference between the datalogger and the AM16/32A.

Some thermocouple wires have a greater resistance than copper, which adds resistance to the non-thermocouple sensor circuit. For example, constantan is approximately 26 times more resistive than copper.

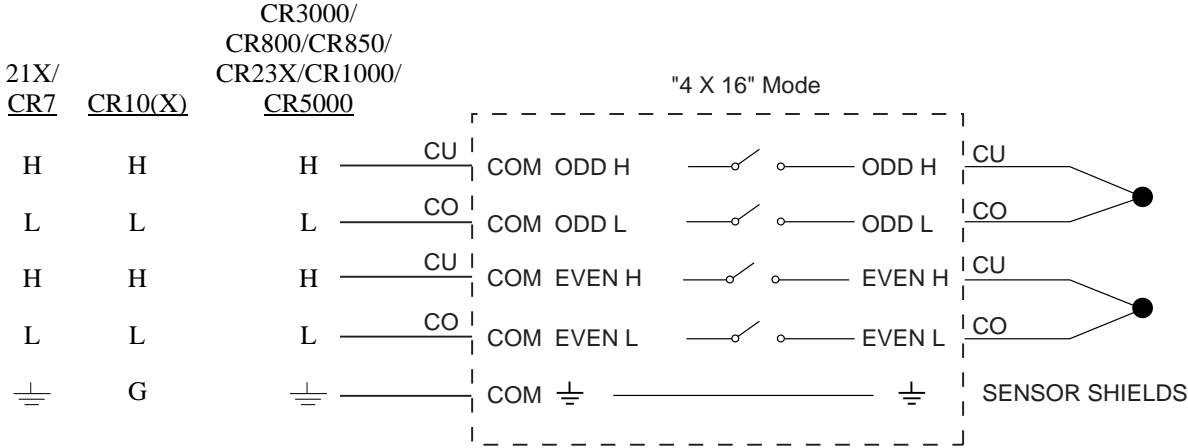

FIGURE 17. Differential Thermocouple Measurement with Reference Junction at the Datalogger.

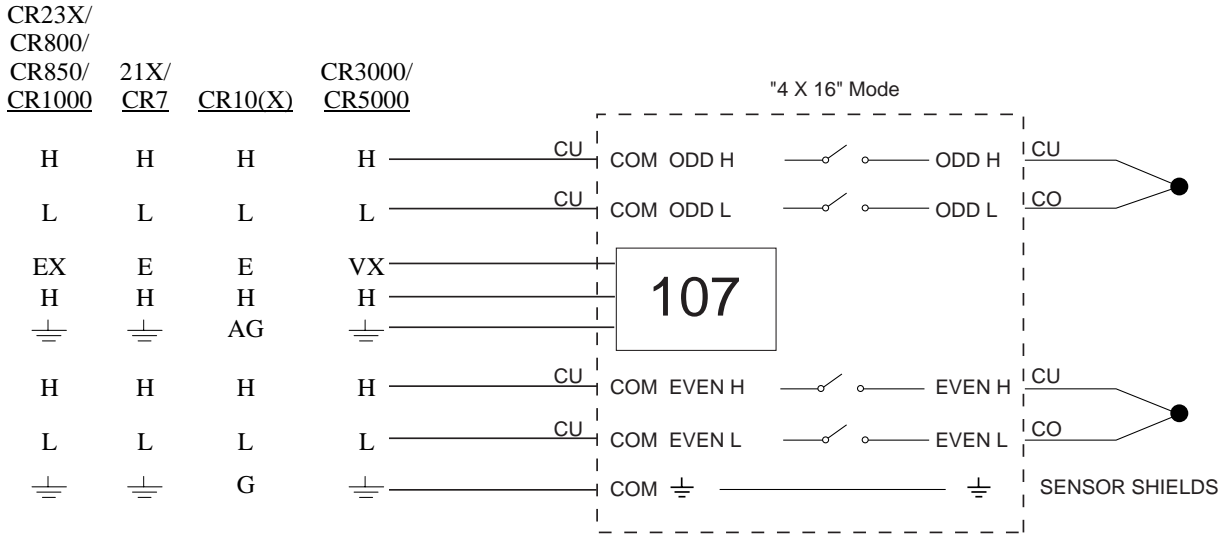

FIGURE 18. Differential Thermocouple Measurement with Reference Junction at the AM16/32A.

If a mix of TCs and other sensor types are multiplexed through the AM16/32A, it is generally best to locate the reference junction on the AM16/32A, as shown in Figure 18.

AM16/32A Reference - An external reference, usually a thermistor, can be located at the AM16/32A, as shown in Figure 18. This approach requires an additional single-ended datalogger input to measure the reference. Position the reference next to the COM terminals and, when practical, measure the thermocouples on SETs that are in close proximity to the COM terminals in order to minimize thermal gradients.

Thermal Gradients - Thermal gradients between the AM16/32A's sensor input terminals and COM terminals can cause errors in thermocouple readings. For example, with type T thermocouples, a one degree gradient between the input terminals and the COM terminals will result in an approximate one degree measurement error. Installing the aluminum cover plate (included with AM16/32A) helps to minimize gradients. For best results the AM16/32A should be shielded and insulated from all radiant and conducted thermal sources. When an enclosure is used, gradients resulting from heat conducted along the thermocouple wire can be minimized by coiling some wire inside the enclosure. This technique allows heat to largely dissipate before it reaches the terminals. If the AM16/32A is housed in a field enclosure, the enclosure should be shielded from solar radiation.



FIGURE 19. AM16/32A Aluminum Cover Plate

### 6.6.2 Single-ended Thermocouple Measurement

In single-ended thermocouple measurements, the following precautions must be taken to ensure accurate measurement:

Only shielded thermocouple wire should be used; the sensor shields should be tied to multiplexer input shield (“ $\frac{\perp}{\perp}$ ”) terminals.

Exposed ends of thermocouples measuring soil temperature should be electrically insulated to prevent differences in ground potential among the thermocouples from causing errors in the measured temperatures.

AM16/32A panel switch set to “4x16” mode.

Sensor to Multiplexer wiring - up to three thermocouples per SET; the high side of each thermocouple is input into terminals ODD H, ODD L, and EVEN H. The low sides of each thermocouple are multiplexed in common through terminal EVEN L.

Multiplexer to Datalogger wiring - If the reference junction is at the datalogger, then the wire that connects the COM ODD H, COM ODD L, and COM EVEN H terminals to the datalogger should be of the same composition as the high side of the thermocouples. Also, the wire that connects COM EVEN L to datalogger ground should be of the same composition as the low side of the thermocouples.

If the reference junction is at the AM16/32A (CSI 107 thermistor, RTD, etc.), then copper wire should be used to connect COM terminals to the datalogger.

### **6.6.3 Differential Thermocouple Measurement**

AM16/32A panel switch set to “2x32” mode.

Multiplexer to Datalogger wiring - The wire types here can be handled in one of two ways. If a reference junction (107 thermistor, or RTD, etc.) is at the AM16/32A, then one copper wire may be run between the COM terminals of the multiplexer and the datalogger input channel.

If the reference junction is at the datalogger, then matching thermocouple wire should be run between the COM terminals of the multiplexer and the differential input channel on the datalogger (observe TC wire polarity).

## **6.7 Mixed Sensor Types**

In applications where sensor types are mixed, multiple hook-up configurations and programming sequences are possible. Please consult CSI for application assistance if you need to multiplex markedly different sensor types in your application.

### **6.7.1 Mixed Sensor Example: Soil Moisture Blocks and Thermocouples**

AM16/32A panel switch set to “4x16” mode.

In this example, 16 thermocouples and 16 soil moisture blocks will be multiplexed through the AM16/32A. One thermocouple and one soil moisture block are input into each SET.

**CR10X Example Program – Thermocouple and Soil Block Measurement**

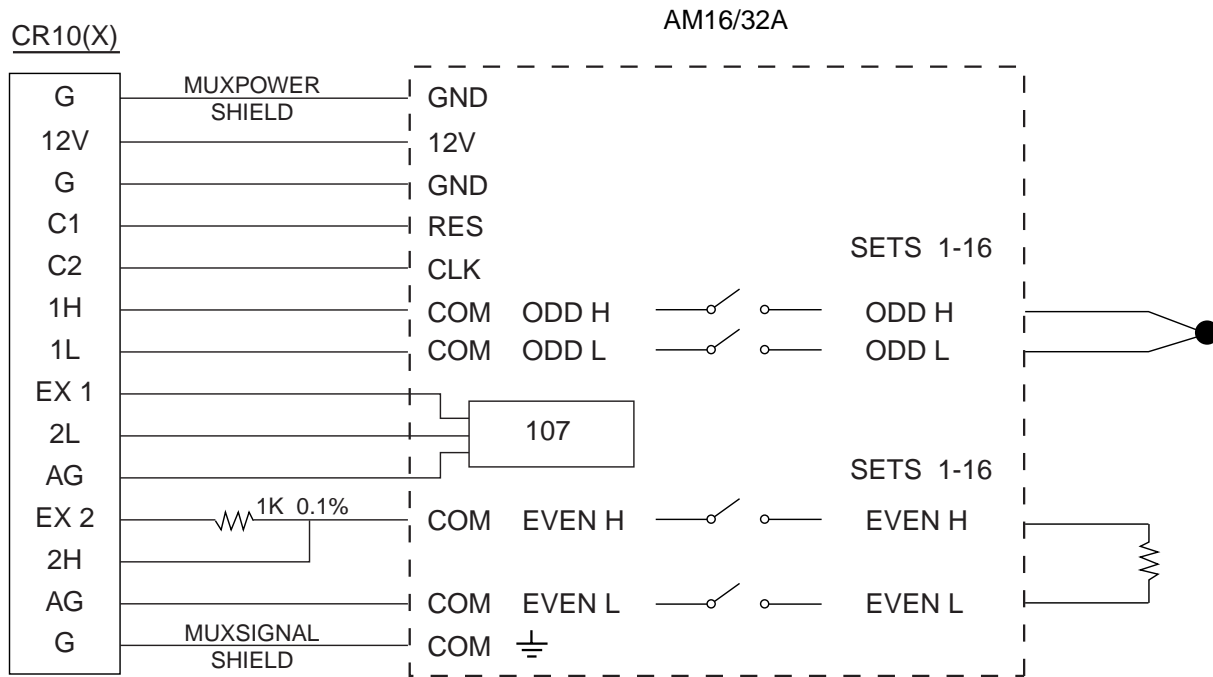

FIGURE 20. Thermocouple and Soil Block Measurement for CR10X Example

33 LOCATIONS ALLOCATED TO INPUT STORAGE)

*1	Table 1 Programs
1: 60	Sec. Execution Interval
REFERENCE TEMPERATURE FOR THERMOCOUPLES	
1: Temp 107 Probe (P11)	
1: 1	Rep
2: 4	IN Chan
3: 1	Excite all reps w/EXchan 1
4: 1	Loc [:REFTEMP ]
5: 1	Mult
6: 0	Offset
ENABLES MULTIPLEXER	
2: Do (P86)	
1: 41	Set high Port 1
BEGINS MEASUREMENT LOOP	
3: Beginning of Loop (P87)	
1: 0	Delay
2: 16	Loop Count

## CLOCK PULSE

4: Do (P86)

1: 72 Pulse Port 2

5: Excitation with Delay (P22)

1: 1 EX Chan  
 2: 2 Delay w/EX (units=.01 sec)  
 3: 0 Delay after EX (units=.01 sec)  
 4: 1 mV Excitation  
 5: 0

## MEASURES 1 THERMOCOUPLE PER LOOP

6: Thermocouple Temp (DIFF) (P14)

1: 1 Rep  
 2: 1 2.5 mV slow Range  
 3: 1 IN Chan  
 4: 1 Type T (Copper-Constantan)  
 5: 1 Ref Temp Loc REFTEMP  
 6: 2-- Loc [:TC #1 ]  
 7: 1 Mult  
 8: 0 Offset

## MEASURES 1 SOIL MOISTURE BLOCK PER LOOP

7: AC Half Bridge (P5)

1: 1 Rep  
 2: 14 250 mV fast Range  
 3: 3 IN Chan  
 4: 2 Excite all reps w/EXchan 2  
 5: 250 mV Excitation  
 6: 18-- Loc [:SOIL M #1]  
 7: 1 Mult  
 8: 0 Offset

## ENDS MEASUREMENT LOOP

8: End (P95)

## DISABLES MULTIPLEXER

9: Do (P86)

1: 51 Set low Port 1

## CALCULATES BRIDGE TRANSFORM ON SOIL MOISTURE BLOCKS

10: BR Transform Rf[X/(1-X)] (P59)

1: 16 Repts  
 2: 18 Loc [:SOIL M #1]  
 3: 1 Multiplier (Rf)

11: End Table 1 (P)

## INPUT LOCATION LABELS:

1:REFTEMP      19:SOIL M #2  
 2:TC #1        20:SOIL M #3  
 3:TC #2        21:SOIL M #4  
 4:TC #3        22:SOIL M #5  
 5:TC #4        23:SOIL M #6

6:TC #5	24:SOIL M #7
7:TC #6	25:SOIL M #8
8:TC #7	26:SOIL M #9
9:TC #8	27:SOIL M#10
10:TC #9	28:SOIL M#11
11:TC #10	29:SOIL M#12
12:TC #11	30:SOIL M#13
13:TC #12	31:SOIL M#14
14:TC #13	32:SOIL M#15
15:TC #14	33:SOIL M#16
16:TC #15	34:_____
17:TC #16	35:_____
18:SOIL M #1	36:_____

**CR1000 Example Program – Thermocouple and Soil Block Measurement**

```
'CR1000 Series Datalogger

'Declare Public Variables

Public PTemp, batt_volt, TCTemp(16), Soil(16)
Dim I                                     'Counter for setting Array element

'Define Data Tables
DataTable (Avg15Min,1,-1)
    DataInterval (0,5,Min,10)
    Minimum (1,batt_volt,FP2,0,False)
    Average (1,PTemp,IIEEE4,False)
    Average (16,TCTemp(),IIEEE4,False)
    Average (16,Soil(),IIEEE4,False)
EndTable

'Main Program
BeginProg
    Scan (1,Sec,0,0)
        PanelTemp (PTemp,250)
        Battery (Batt_volt)
    'Activate Multiplexer Index
        PortSet (1 ,1 )
        I=0
    'Begin Measurement Loop
        SubScan (0,Sec,16)
        'Clock Pulse and Delay
        PortSet (2 ,1 )                               'Set port 2 high
        Delay (0,20,mSec)
        PortSet (2 ,0)
    'Increment Index and Measure
        I=I+1
        TCDiff (TCTemp(I),1,mV2_5C,1,TypeT,PTemp,True ,0,250,1.0,0)
        BrHalf (Soil(I),1,mV2500,3,Vx2,1,2500,True ,0,250,1.0,0)
    'End Measurement Loop
        NextSubScan
```



```

'Deactivate Multiplexer
  PortSet (1 ,0)
  'Call Data Table
  CallTable Avg15Min
Next Scan
EndProg

```

## 7. General Measurement Considerations

Long lead lengths – Longer sensor-to-AM16/32A leads result in greater induced and capacitively coupled voltages (cross-talk) between cable wires. To minimize capacitive effects CSI recommends the use of cabling having Teflon, polyethylene, or polypropylene insulation around individual conductors. You should not use cables with PVC insulation around individual conductors (PVC cable jacket is acceptable). It may also be necessary to program a delay within the measurement instruction allowing time for lead wire capacitances to discharge after advancing a channel, before the measurement is made. Please consult the theory of operation section of your datalogger manual for more information.

Earth Ground – The AM16/32A's ground lug should be connected to earth ground via an 8 AWG wire. This connection should be as short as possible. The AM16/32A also connects to earth ground via the datalogger. The lead wire that connects the datalogger power ground to the AM16/32A power ground ("GND") establishes this connection. The Installation/Maintenance Section of your datalogger manual contains more information on grounding procedures.

Completion resistors - In some applications it is advantageous to place completion resistors at the datalogger terminal strips. Certain sensors specific to the use of multiplexers are available from CSI. Examples include soil moisture probes and thermistor probes. Please consult CSI for ordering and pricing information.

Contact degradation - Once excitation in excess of 30 mA has been multiplexed, that channel's relay contacts have been rendered unsuitable for further low voltage measurement. To prevent undue degradation, it is advisable to reserve certain channels for sensor excitation and employ other channels for sensor signals.

## 8. Installation

The standard AM16/32A may be operated in an indoor, non-condensing environment. If condensing humidity is present or if the possibility exists that the multiplexer might be exposed to liquids, a water-resistant enclosure is required.

Several enclosures are available for purchase through CSI (models ENC 10/12, ENC 12/14, ENC 14/16, and ENC 16/18). They offer a degree of protection against dust, spraying water, oil, falling dirt, or dripping, noncorrosive liquids. These enclosures contain a mounting

plate with 1-inch hole grid suitable for mounting the AM16/32A. The enclosures have a cable bushing to accommodate the sensor lines. These standard enclosures are rain-tight, but not water-proof.

The enclosure lids are gasketed. The screws on the outside of the enclosure should be tightened to form a restrictive seal. In high humidity environments, user supplied foam, putty, or similar material helps to reduce the passage of moisture into the enclosure via cable conduits.

## 8.1 Mounting Tabs

The AM16/32A has mounting tabs allowing attachment by four screws. See Figure 21 dimensions.

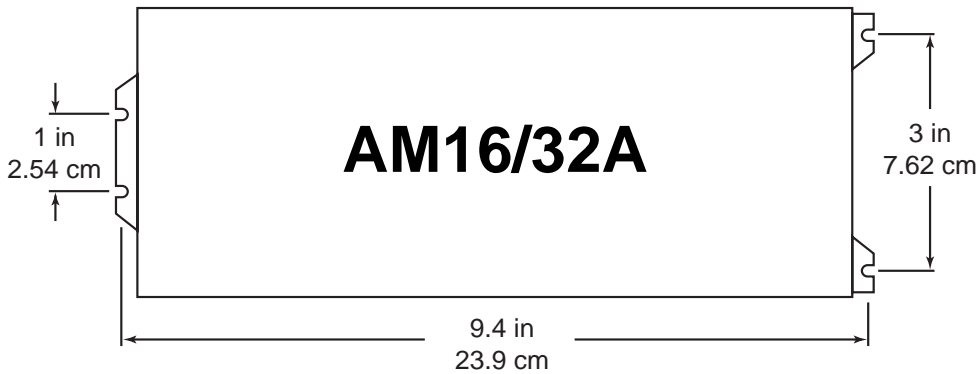

FIGURE 21. Mounting Tab Hole Pattern

U-bolts are provided with enclosure to attach to a 1.25 inch (32 mm) diameter pipe. An enclosure may also be lag-bolted to a wall or other flat surface.

## 8.2 Controlling Humidity

The multiplexer is susceptible to corrosion in high relative humidity. Desiccant packs are available from CSI and should be used inside the enclosure to remove water vapor.

---

### CAUTION

Air movement should not be restricted through an enclosure containing batteries that may produce explosive or noxious gases (e.g., lead-acid batteries).

---

# ***Appendix A. AM16/32A Improvements***

---

The AM16/32A replaced the AM16/32 in October 2006. The AM16/32A's improvements over the AM16/32 are better ESD and surge protection, a main ground lug, and a newer processor. The AM16/32A is wired and programmed the same as its predecessor, the AM16/32.





## **Campbell Scientific Companies**

---

### **Campbell Scientific, Inc. (CSI)**

815 West 1800 North  
Logan, Utah 84321  
UNITED STATES  
www.campbellsci.com  
info@campbellsci.com

### **Campbell Scientific Africa Pty. Ltd. (CSAf)**

PO Box 2450  
Somerset West 7129  
SOUTH AFRICA  
www.csafrica.co.za  
cleroux@csafrica.co.za

### **Campbell Scientific Australia Pty. Ltd. (CSA)**

PO Box 444  
Thuringowa Central  
QLD 4812 AUSTRALIA  
www.campbellsci.com.au  
info@campbellsci.com.au

### **Campbell Scientific do Brazil Ltda. (CSB)**

Rua Luisa Crapsi Orsi, 15 Butantã  
CEP: 005543-000 São Paulo SP BRAZIL  
www.campbellsci.com.br  
suporte@campbellsci.com.br

### **Campbell Scientific Canada Corp. (CSC)**

11564 - 149th Street NW  
Edmonton, Alberta T5M 1W7  
CANADA  
www.campbellsci.ca  
dataloggers@campbellsci.ca

### **Campbell Scientific Ltd. (CSL)**

Campbell Park  
80 Hathern Road  
Shepshed, Loughborough LE12 9GX  
UNITED KINGDOM  
www.campbellsci.co.uk  
sales@campbellsci.co.uk

### **Campbell Scientific Ltd. (France)**

Miniparc du Verger - Bat. H  
1, rue de Terre Neuve - Les Ulis  
91967 COURTABOEUF CEDEX  
FRANCE  
www.campbellsci.fr  
info@campbellsci.fr

### **Campbell Scientific Spain, S. L.**

Psg. Font 14, local 8  
08013 Barcelona  
SPAIN  
www.campbellsci.es  
info@campbellsci.es