

# INSTRUCTION MANUAL



## **CM106K Tripod**

Revision: 3/12



Copyright © 2011-2012  
Campbell Scientific, Inc.



# Warranty

---

“PRODUCTS MANUFACTURED BY CAMPBELL SCIENTIFIC, INC. are warranted by Campbell Scientific, Inc. (“Campbell”) to be free from defects in materials and workmanship under normal use and service for twelve (12) months from date of shipment unless otherwise specified in the corresponding Campbell pricelist or product manual. Products not manufactured, but that are re-sold by Campbell, are warranted only to the limits extended by the original manufacturer. Batteries, fine-wire thermocouples, desiccant, and other consumables have no warranty. Campbell's obligation under this warranty is limited to repairing or replacing (at Campbell's option) defective products, which shall be the sole and exclusive remedy under this warranty. The customer shall assume all costs of removing, reinstalling, and shipping defective products to Campbell. Campbell will return such products by surface carrier prepaid within the continental United States of America. To all other locations, Campbell will return such products best way CIP (Port of Entry) INCOTERM® 2010, prepaid. This warranty shall not apply to any products which have been subjected to modification, misuse, neglect, improper service, accidents of nature, or shipping damage. This warranty is in lieu of all other warranties, expressed or implied. The warranty for installation services performed by Campbell such as programming to customer specifications, electrical connections to products manufactured by Campbell, and product specific training, is part of Campbell's product warranty. **CAMPBELL EXPRESSLY DISCLAIMS AND EXCLUDES ANY IMPLIED WARRANTIES OF MERCHANTABILITY OR FITNESS FOR A PARTICULAR PURPOSE.** Campbell is not liable for any special, indirect, incidental, and/or consequential damages.”

# Assistance

---

Products may not be returned without prior authorization. The following contact information is for US and international customers residing in countries served by Campbell Scientific, Inc. directly. Affiliate companies handle repairs for customers within their territories. Please visit [www.campbellsci.com](http://www.campbellsci.com) to determine which Campbell Scientific company serves your country.

To obtain a Returned Materials Authorization (RMA), contact CAMPBELL SCIENTIFIC, INC., phone (435) 227-9000. After an applications engineer determines the nature of the problem, an RMA number will be issued. Please write this number clearly on the outside of the shipping container. Campbell Scientific's shipping address is:

**CAMPBELL SCIENTIFIC, INC.**

RMA# \_\_\_\_\_  
815 West 1800 North  
Logan, Utah 84321-1784

For all returns, the customer must fill out a "Statement of Product Cleanliness and Decontamination" form and comply with the requirements specified in it. The form is available from our web site at [www.campbellsci.com/repair](http://www.campbellsci.com/repair). A completed form must be either emailed to [repair@campbellsci.com](mailto:repair@campbellsci.com) or faxed to (435) 227-9106. Campbell Scientific is unable to process any returns until we receive this form. If the form is not received within three days of product receipt or is incomplete, the product will be returned to the customer at the customer's expense. Campbell Scientific reserves the right to refuse service on products that were exposed to contaminants that may cause health or safety concerns for our employees.

# CM106K Table of Contents

---

PDF viewers: These page numbers refer to the printed version of this document. Use the PDF reader bookmarks tab for links to specific sections.

|  |           |
|--|-----------|
| <b>1. Cautionary Statements</b> .....                                    | <b>1</b>  |
| 1.1 Site Selection .....   | 1         |
| 1.2 Tripod Mounting.....   | 1         |
| 1.3 Tripod Installation .....  | 1         |
| <b>2. Tripod Installation</b> .....                                      | <b>2</b>  |
| 2.1 Tripod Base Assembly.....  | 2         |
| 2.1.1 Parts List .....   | 2         |
| 2.1.2 Leg Assembly .....   | 3         |
| 2.2 Tripod Base Positioning .....  | 6         |
| 2.2.1 Mounting on a Relatively Flat Area.....                            | 7         |
| 2.2.2 Mounting on an Incline.....  | 7         |
| 2.3 Mast .....   | 8         |
| 2.4 Installing the Optional Guy Kit .....                                | 9         |
| 2.5 Staking the Tripod Feet .....  | 11        |
| 2.6 Tripod Grounding.....  | 12        |
| 2.7 Crossarm Attachment .....  | 14        |
| 2.8 Enclosure Attachment.....  | 14        |
| 2.8.1 Enclosure Mounting to Tripod Mast.....                             | 14        |
| 2.8.2 Enclosure Mounting to Tripod Leg.....                              | 15        |
| <b>3. General</b> .....  | <b>17</b> |
| <b>4. Specifications</b> .....   | <b>18</b> |
| <b>5. Tools List (for tripod, mast, enclosures, and crossarms)</b> ..... | <b>18</b> |
| <b>6. Tripod Components</b> .....  | <b>19</b> |
| <b>7. Mounting Brackets</b> .....  | <b>19</b> |
| 7.1 CM210 Crossarm Mounting Kit.....                                     | 19        |
| 7.2 CM216 Mast Mounting Kit .....  | 20        |
| 7.3 CM220 Right Angle Mounting Kit.....                                  | 21        |
| 7.4 CM225 and 18098 Pyranometer Mounting Stand .....                     | 22        |
| 7.5 CM230 Adjustable Angle Mounting Kit .....                            | 23        |
| 7.6 CM235 Magnetic Mounting Stand .....                                  | 24        |
| 7.7 RM Young Gill Radiation Shields.....                                 | 25        |

## Figures

|   |    |
|---|----|
| 2-1. Tripod component dimensions .....  | 3  |
| 2-2. Comparison of one leg pointing downhill (right) versus two legs<br>pointing downhill ..... | 7  |
| 2-3. Guy collar .....   | 9  |
| 2-4. Anchor attachment.....   | 10 |
| 2-5. Staking the tripod feet.....   | 11 |
| 2-6. Ground rod and clamp .....   | 12 |
| 2-7. Lightning rod and tripod grounding lug .....   | 13 |
| 2-8. CM204 Crossarm.....  | 14 |
| 2-9. Enclosure with the –MM Bracket.....  | 15 |
| 2-10. Enclosure with the –LM Bracket.....   | 16 |
| 3-1. Typical tripod-based weather station .....   | 17 |
| 7-1. CM210 Crossarm Mounting Kit (shown with user-supplied pipe) .....                          | 19 |
| 7-2. CM216 Mast Mounting Kit .....  | 20 |
| 7-3. CM220 Right Angle Mounting Kit.....  | 21 |
| 7-4. CM225 Pyranometer Mounting Stand.....  | 22 |
| 7-5. CM230 Adjustable Angle Mounting Kit .....  | 23 |
| 7-6. CM235 Magnetic Mounting Stand .....  | 24 |
| 7-7. RM Young Gill Radiation Shield .....   | 25 |

# ***CM106K Tripod***

---

## **1. Cautionary Statements**

### **1.1 Site Selection**

- Select a safe site to install the tripod.
- The distance between any power lines and the installation site should be at least one and one-half times the height of the tripod. Make the distance even greater, if at all possible. Since all overhead power lines look somewhat alike, consider them all dangerous and stay well away from them.
- If you have power lines or buried utilities in the area, call your local utility providers for assistance.

### **1.2 Tripod Mounting**

- NEVER work alone; always have someone near who can summon help.
- Certain clothing may provide a degree of safety, but don't depend on it for your life (rubber boots or shoes, industrial rubber gloves and a long sleeve shirt or jacket).
- Check weather conditions. Be sure that it hasn't rained recently and that the ground is not wet or muddy. Make sure that rain or thunderstorms are not predicted for the day you decide to install the tripod.
- The wind can blow the tripod into a nearby power line. Don't install or remove tripods in moderate or heavy winds.
- If you need to use a ladder, make sure it is made of non-conductive (non-metallic) material. (This is a safety rule that you should follow whenever you're working with electrical equipment.)
- If possible, have someone present who has been trained in electric shock first aid.

### **1.3 Tripod Installation**

- Properly assemble the tripod according to instructions (do this where the tripod is to be put up).
- Once the tripod is up in full vertical position, securely fasten it to the ground using ground spikes. For situations where soil structure is questionable or the tripod may experience high wind loads, concrete footings for the tripod feet and guy anchors should be considered.
- Ground the tripod according to the National Electrical Code.

## 2. Tripod Installation

### 2.1 Tripod Base Assembly

#### 2.1.1 Parts List

| Part # | Description                  | Qty |
|--------|------------------------------|-----|
| 10838  | Tripod Foot                  | 3   |
| 27392  | CM106K Body                  | 3   |
| 19308  | Spacer                       | 6   |
| 4366   | 5/16" Lock Washer            | 6   |
| 19175  | 5/16-18x2.25" Bolt           | 6   |
| 18126  | 5/16-18 Bronze Nut           | 6   |
| 19031  | Grounding Clamp              | 2   |
| 27113  | #10-32 x 0.75" Bolt          | 4   |
| 1201   | Clamp Bracket                | 3   |
| 75     | 5/16-18 x 0.75" Bolt         | 3   |
| 795    | ¼-20 Nylock Nut              | 6   |
| 794    | ¼-20 x 1.75" Bolt            | 12  |
| 850    | CM10 Lightning Rod           | 1   |
| 17589  | Lightning Rod Clamp Assembly | 1   |



### 2.1.2 Leg Assembly

1. Refer to Figure 2-1 to create the following parts:

- Three (3) Leg Braces
- Three (3) Legs
- One (1) Mast

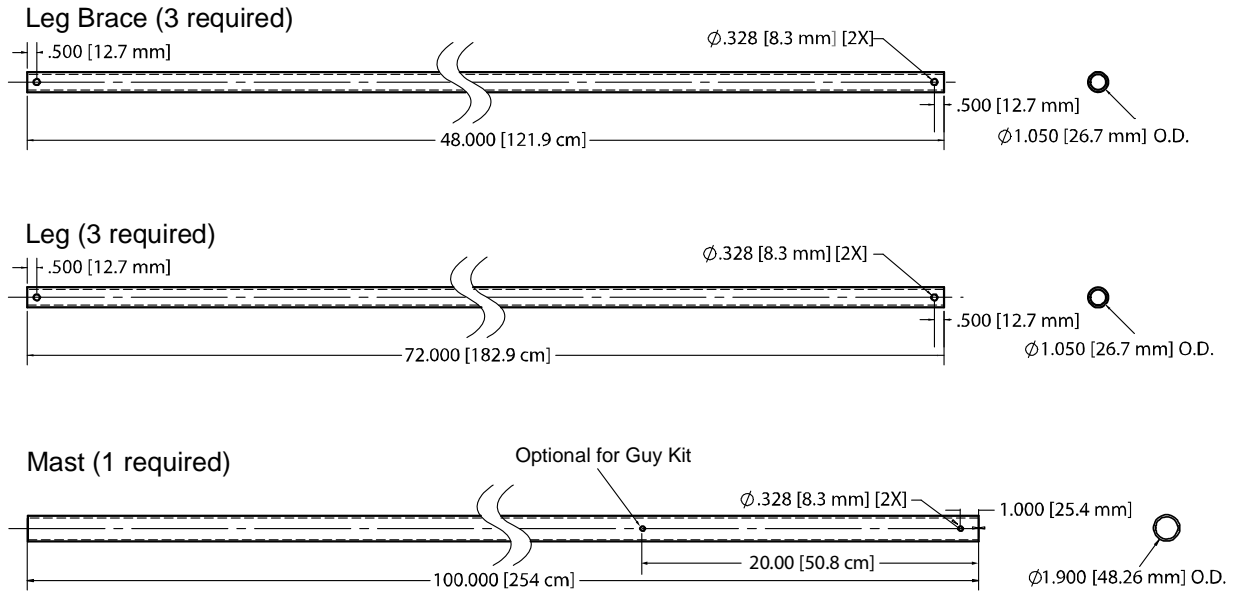

|           | Material                      | Wall Thickness       | Length              | QTY |
|-----------|-------------------------------|----------------------|---------------------|-----|
| Leg Brace | 3/4 NPS SCH40<br>[DN 20 mm]   | 0.113"<br>[2.87 mm]  | 48.0"<br>[121.9 cm] | 3   |
| Leg       | 3/4 NPS SCH40<br>[DN 20 mm]   | 0.113"<br>[2.87 mm]  | 72.0"<br>[182.9 cm] | 3   |
| Mast      | 1 1/2 NPS SCH40<br>[DN 40 mm] | 0.145"<br>[3.683 mm] | 100.0"<br>[254 cm]  | 1   |

Mast and mast legs must be made of Steel  
 (Minimum yield Strength of 36 ksi [248 MPa])

FIGURE 2-1. Tripod component dimensions

- Using a 1/4-20 x 1.75" bolt and 1/2-20 nylock nut, attach a foot to each tripod leg (Figure 2-2).

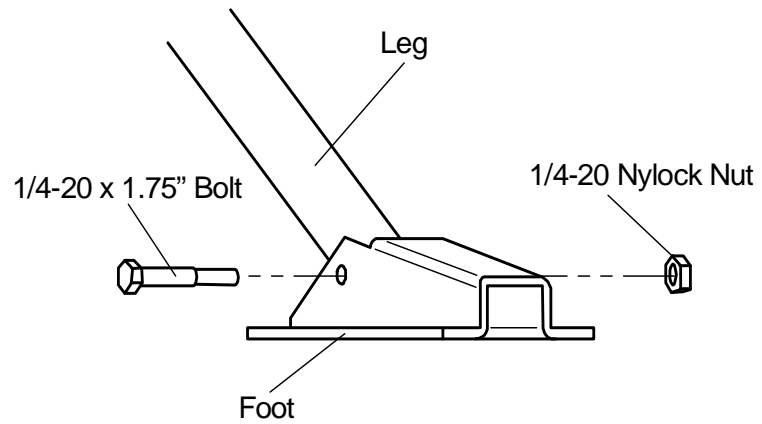

- Slide a clamp bracket onto each leg. Thread a 5/16-18 x 0.75" bolt into the bracket, leaving the bracket free to move. Attach a leg brace to each clamp bracket using a 1/4-20 x 1.75" bolt and nylock nut.

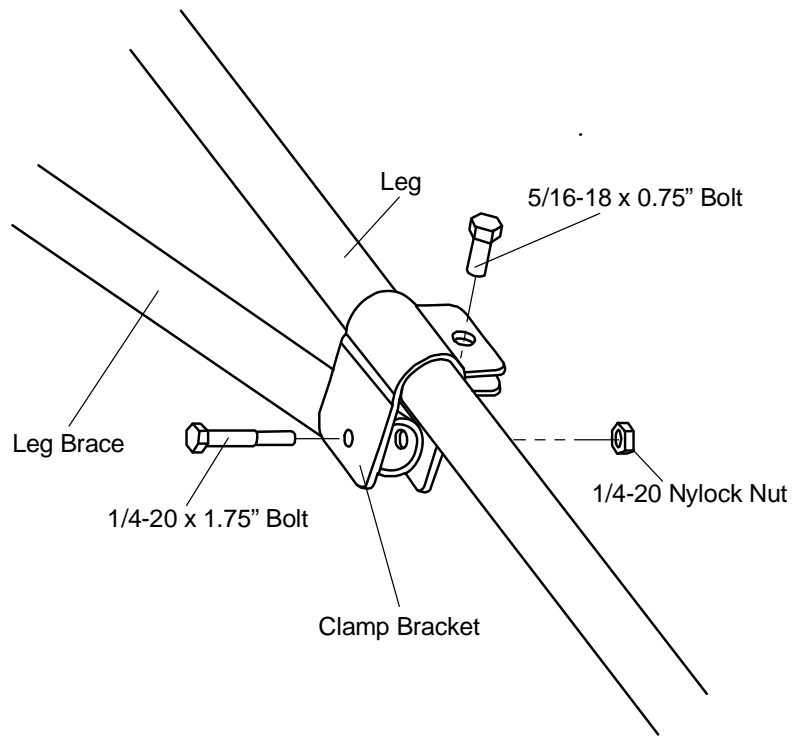

- Pass a 5/16-18 x 2.25" bolt through a mounting hole in one of the tripod body pieces as shown. Slide a spacer over the bolt. Place a second tripod body piece over the end of the bolt, followed by a 5/16 lock washer. Hand tighten a 5/16-18 bronze nut on the end of the bolt. Repeat this process with the other five 5/16-18 x 2.25" bolts to assemble the tripod body.

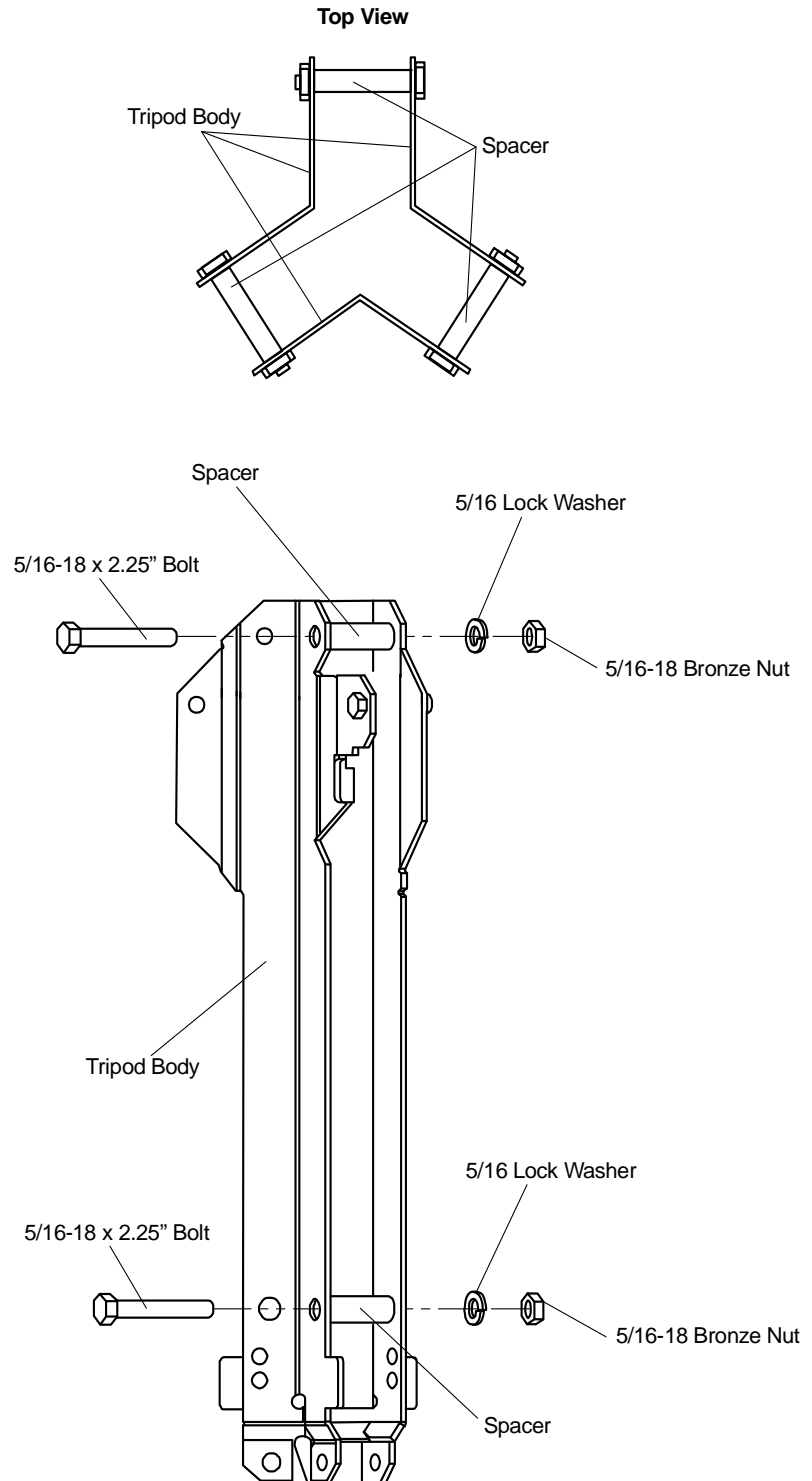

- Attach each leg assembly to the tripod body using two 1/4-20 x 1.75" bolts and nylock nuts. Attach the two grounding clamps using #10-32 x 0.75" bolts. Do not over-tighten the bolts. The tripod legs and leg braces must be able to pivot.

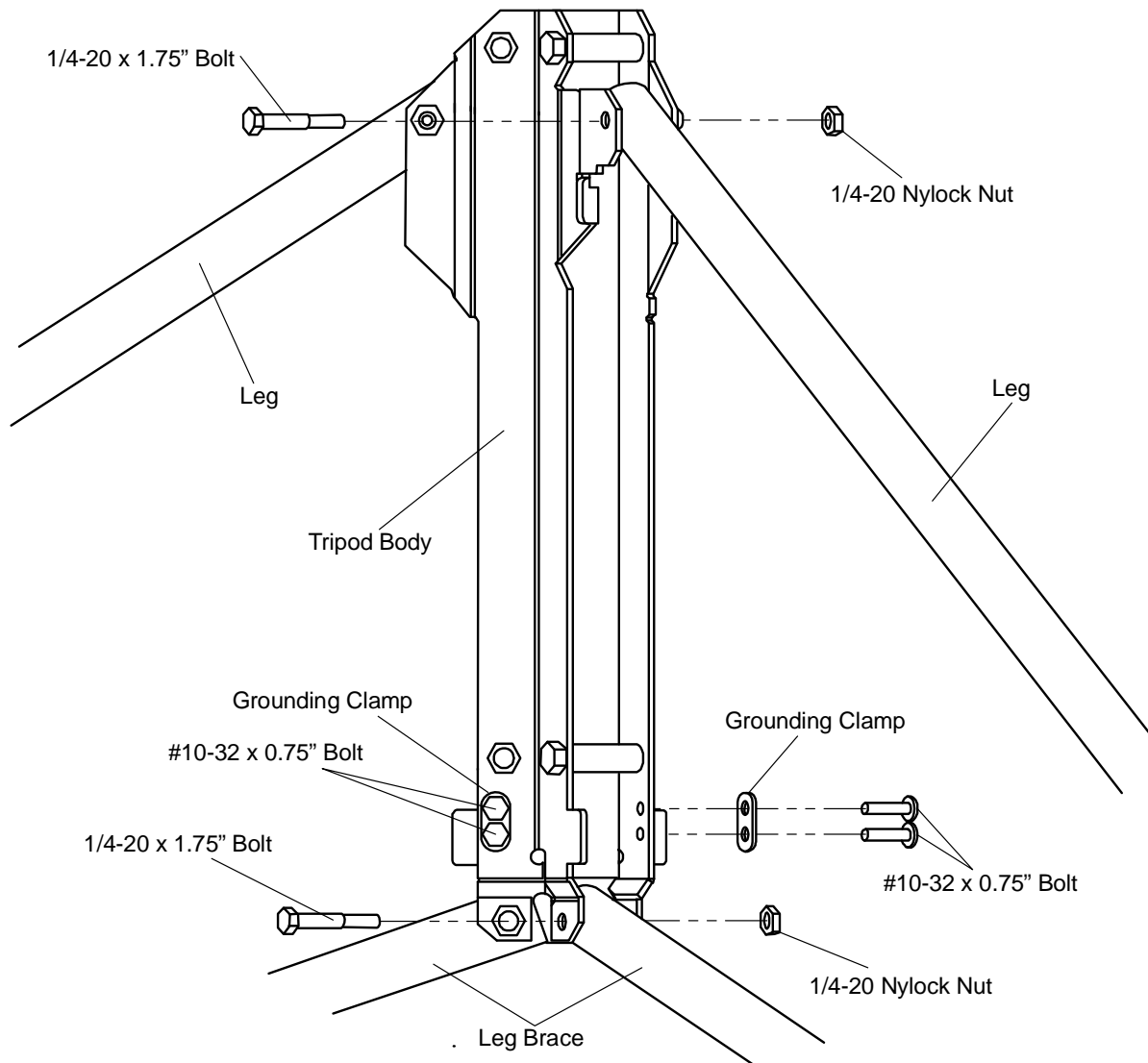

## 2.2 Tripod Base Positioning

### WARNING

**Tripod installation near power lines is dangerous. The minimum safe recommended distance from overhead power lines is 1½ times the height of the tripod and mast combined. Call your local utility providers to locate buried utilities prior to installation.**

The tripod base has three legs, which are individually adjustable, that allow the tripod to be installed over non-level terrain.

Prepare the area where the tripod will be installed. The tripod requires an area approximately 11 ft (3.4 m) in diameter. Natural vegetation and the ground surface should be disturbed as little as possible, but brush and tall weeds should be removed.

Stand the tripod base up on end, and rotate the feet perpendicular to the legs. Each leg has a clamp bracket with a bolt that locks the leg in place when tightened.

### 2.2.1 Mounting on a Relatively Flat Area

Loosen one clamp bracket bolt at a time and extend each leg until the three legs are at the same extension. With the legs extended, orient the tripod so that one of the legs points South (assuming the instrument enclosure with -MM Mast Mount bracket will face North). If the instrument enclosure has the -LM Leg Mount bracket, orient the tripod so that the enclosure will mount to one of the three leg mount positions on the tripod, facing the desired direction. The tripod is typically plumbed after the mast has been installed, as described in Section 2.3.

### 2.2.2 Mounting on an Incline

Loosen the bolts on the clamp brackets. With the legs extended, orient the tripod so that one leg points downhill and the other two legs point uphill. The tripod is more stable with only one leg pointed downhill because the mast is closer to the center of the footprint (see Figure 2-2). Tighten the bolts on the clamp brackets to lock the legs in place.

The tripod is typically plumbed after the mast has been installed, as described in Section 2.3.

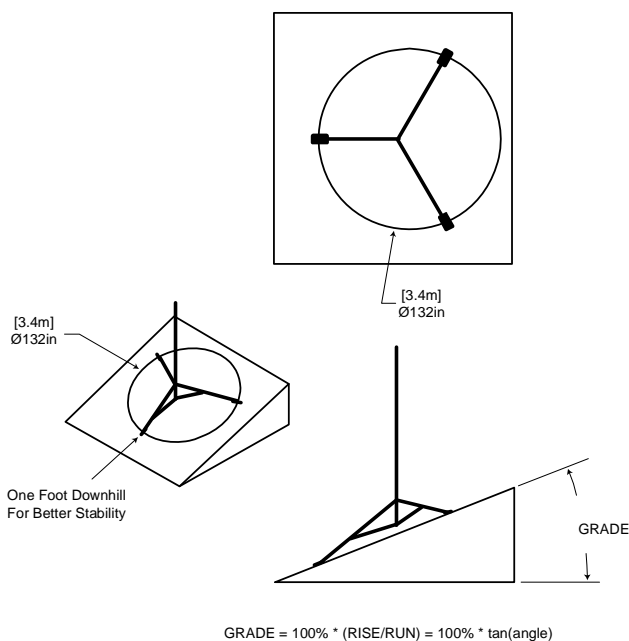

FIGURE 2-2. Comparison of one leg pointing downhill (right) versus two legs pointing downhill

## 2.3 Mast

Slide the mast into the tripod base orienting the end with the hole upwards, making sure that it extends below the lower bolts and rests on the tripod body tabs. Tighten the six 5/16-18 x 2.25" bolts to secure the mast.

Plumb the tripod by adjusting the northeast and south facing legs (use the downhill leg and one of the uphill legs when the tripod is installed on a slope). With a level on the East side of the mast, adjust the Northeast leg for plumb. With the level on the South side of the mast, adjust the South leg for plumb. Tighten the 5/16 bolt on each clamp bracket after the adjustments have been made.

## 2.4 Installing the Optional Guy Kit

PN 27117 CM106 Guy Kit can be ordered separately for areas that experience high wind speeds (Section 4). Install the guy bracket to the mast as shown in Figure 2-3. Attach the three guy wires to the guy collar and slide the collar over the mast so that the collar butts against the bracket.

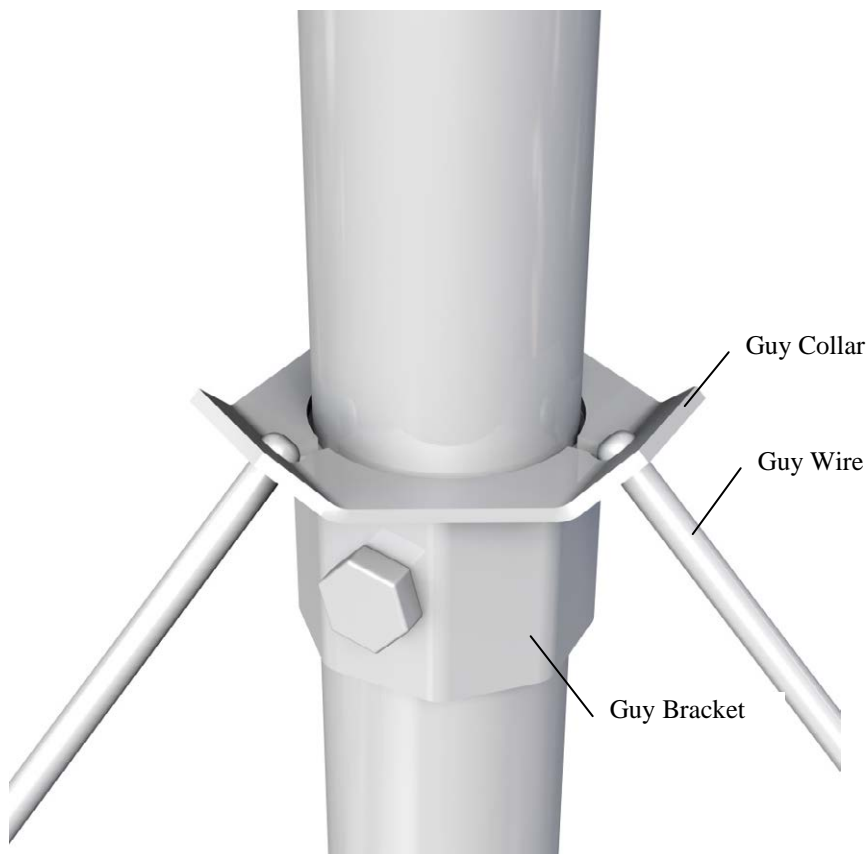

FIGURE 2-3. Guy collar

On the end of each guy line is a case and hardware to attach to the turnbuckles. Unscrew the turnbuckles so that only 1/2 in of thread extends beyond the inside of the turnbuckle body. Attach the case and turnbuckle to secured earth anchors such as those shown in Fig 2-4. For best results, secure the earth anchors in the ground at the same angle the guy wires will be attached. Loosen the Phillips screw, and remove the slack in the guy line by feeding the load end of the guy wire through the wedge while pulling up on the dead end. If the load end of the guy wire can't be fed through the case, use a small flat screwdriver to push the wedge forward into the case to disengage wedge.

After the slack has been removed from the guy lines, tighten the Phillips screws and tighten the turnbuckles to tension each guy line to approximately 100 lbf [45 kgf].

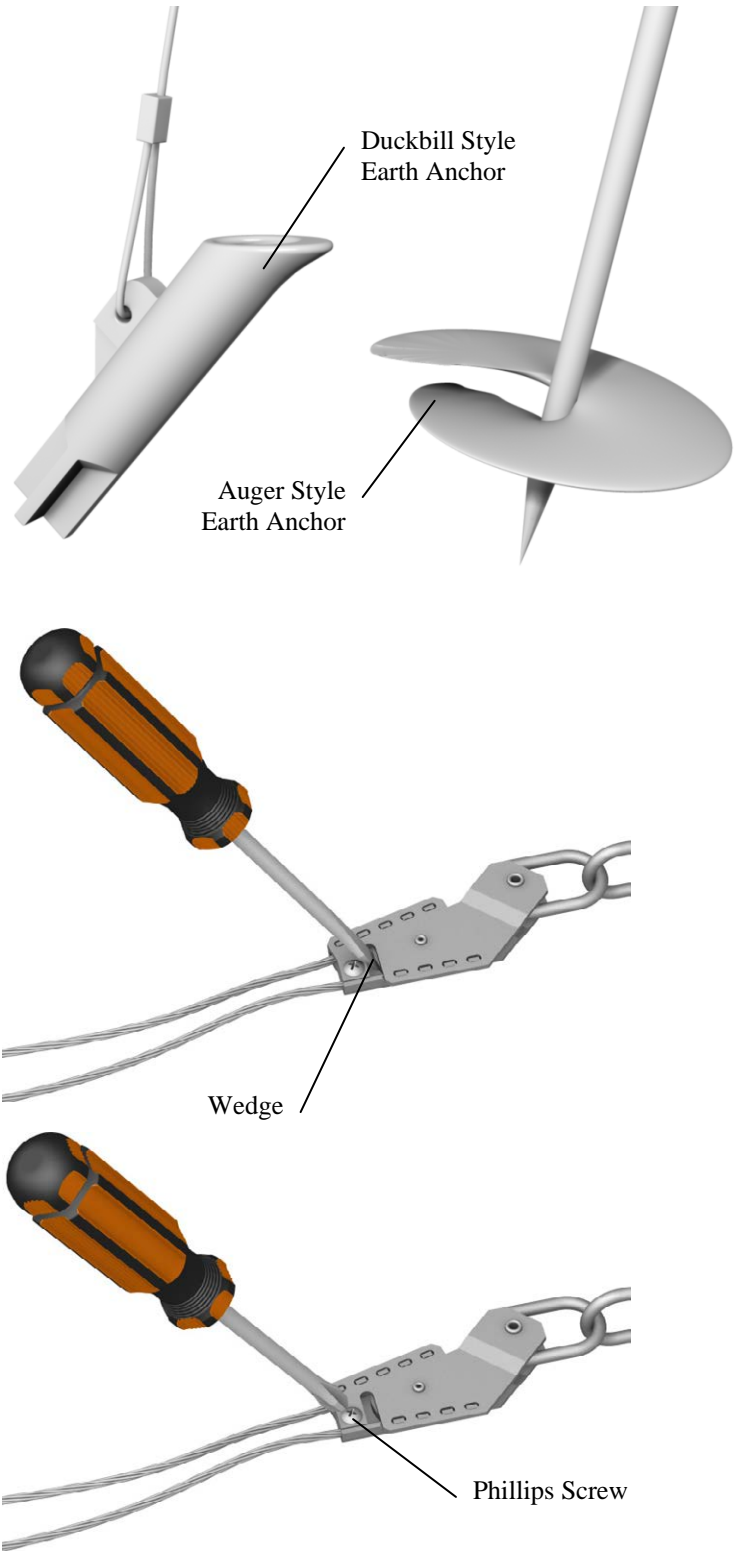

FIGURE 2-4. Anchor attachment



## 2.5 Staking the Tripod Feet

For additional stability, the tripod can be staked to the ground using (3) PN 17049 ground spikes, or secured with user-supplied anchors through the holes in the feet. Drive the spike at an angle through the hole in each foot.

Spikes may not be adequate depending on soil structure, maximum wind speeds experienced at the site, mast height, or wind load from the instrumentation. For questionable situations, concrete footings for the tripod feet and guy anchors should be considered.

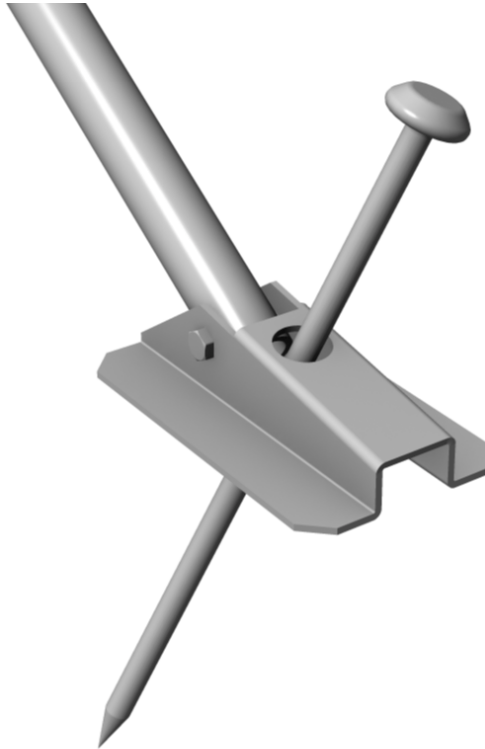
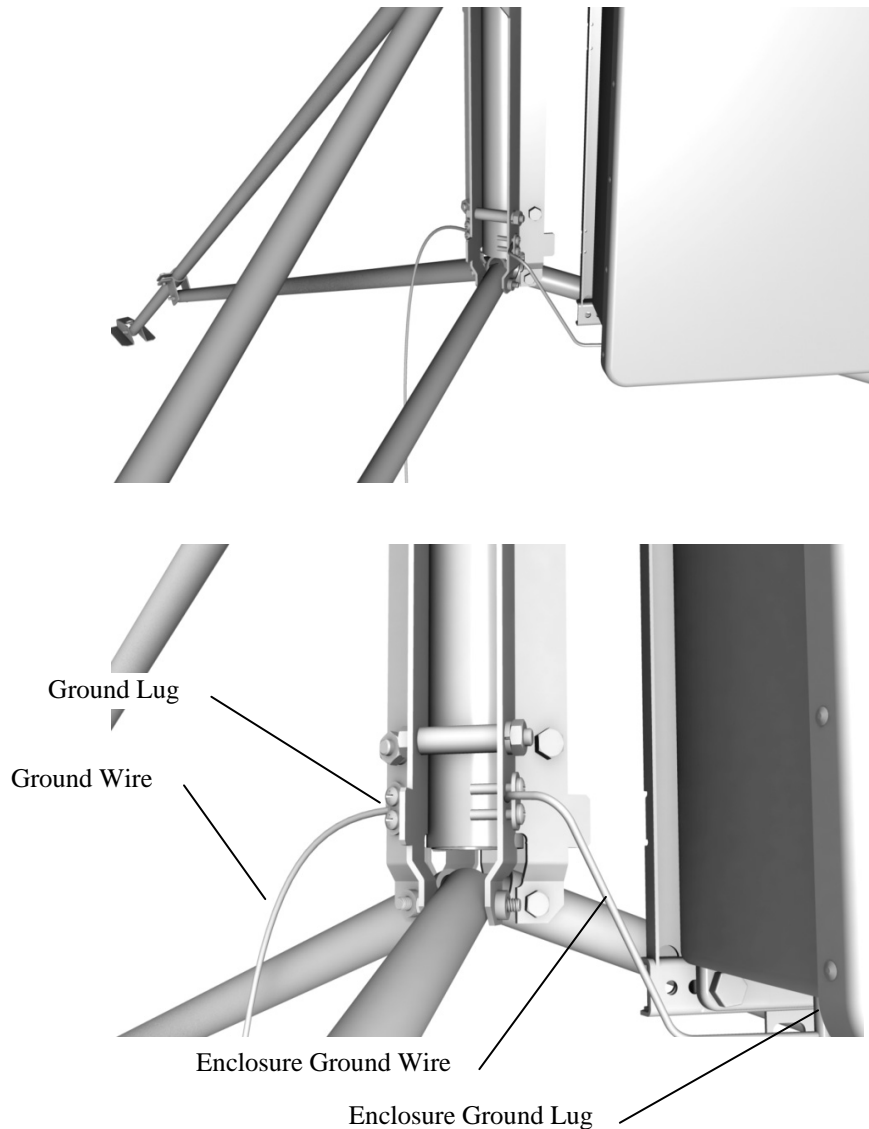

FIGURE 2-5. Staking the tripod feet

## 2.6 Tripod Grounding

The tripod must be properly grounded using a user-supplied grounding rod. Place the clamp over the ground rod and drive the rod (close to the center of the tripod) using a sledge hammer or fence post driver. Strip 1/2" [12.7 mm] inch of insulation from both ends of a 4 AWG ground wire. Insert one end of the ground wire between the clamp and ground rod and tighten the bolt on the clamp. Attach the other end of the ground wire to the lug on the tripod base as shown in Figure 2-6.



**FIGURE 2-6.** *Ground rod and clamp*

Strip 1/2" [12.7 mm] of insulation from the ends of a 12 AWG wire. Attach one end of the wire to the tripod ground lug, and the other end to the enclosure ground lug as shown in Figure 2-6.

Mount the lightning rod and clamp to the tripod mast with pointed tip up, and notch at bottom, as shown in Figure 2-7.

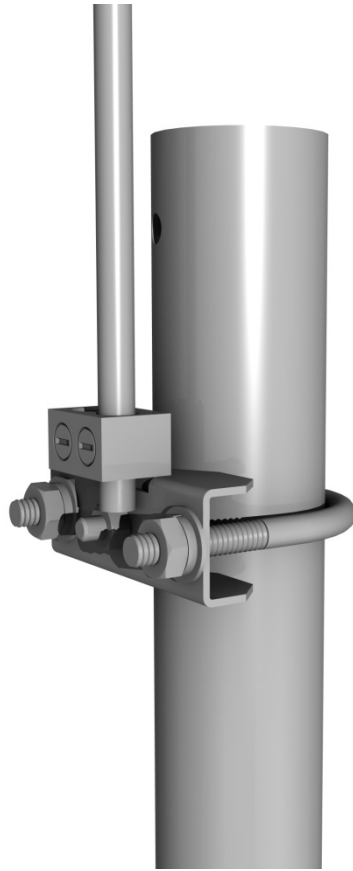

*FIGURE 2-7. Lightning rod and tripod grounding lug*

## 2.7 Crossarm Attachment

Attach the CM202 (2 ft, 0.6m), CM204 (4 ft, 1.2m), or CM206 (6 ft, 1.8m) crossarm to the tripod mast as shown in Figure 2-8. For wind sensors, the crossarm should be approximately 103 inches above the ground. Typically the crossarm is oriented East/West for wind sensors, North/South for pyranometers.

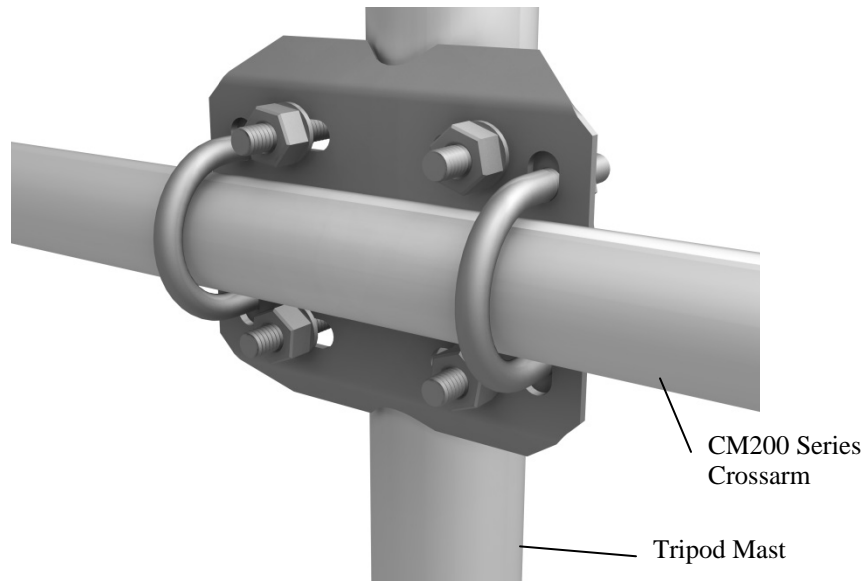

FIGURE 2-8. CM204 Crossarm

## 2.8 Enclosure Attachment

The ENC 10/12, ENC 12/14, ENC 14/16, and ENC 16/18 enclosures can be ordered with mounting brackets for the CM106K tripod. All enclosure models can be mounted to the tripod mast (above the legs) with the –MM Mast Mount bracket option. All enclosure models except the ENC 16/18 can be mounted to the tripod base and leg with the –LM Leg Mount bracket option.

### 2.8.1 Enclosure Mounting to Tripod Mast

An enclosure ordered with the –MM bracket has a three-piece top and bottom brackets with a U-bolt for each bracket.

Attach an enclosure with the –MM mounting bracket to the tripod mast as follows:

Remove the U-bolts washers and nuts from the brackets.

Position the enclosure against the tripod's mast (North side recommended).

Install the U-bolts, flat washers, lock washers, and nuts. Tighten the nuts until the lock washers are compressed.

Route the 14 AWG wire from the grounding lug on the bottom side of the enclosure to the grounding lug on the base of the tripod (Figure 2-6). Strip 1/2" [12.7 mm] of insulation from each end of the wire. Insert wire ends into the grounding lugs and tighten.

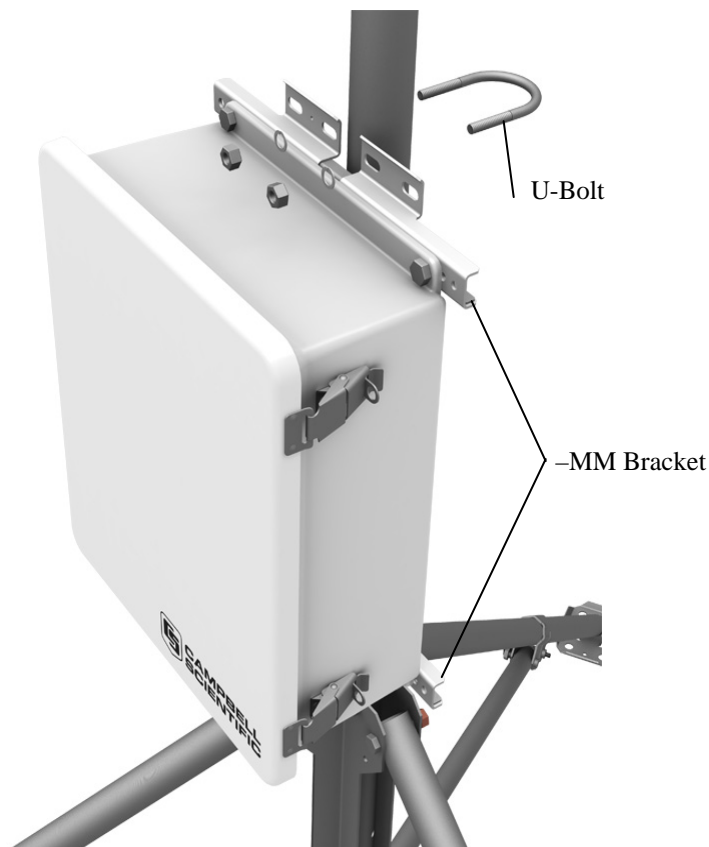

FIGURE 2-9. Enclosure with the -MM Bracket

## 2.8.2 Enclosure Mounting to Tripod Leg

An enclosure ordered with the -LM bracket has a bracket on each side of the enclosure, and a U-bolt bracket for securing the enclosure to a tripod leg.

Attach an enclosure with the -LM mounting bracket to the tripod base as follows:

Slide the keyhole notch in upper corner of the -LM bracket over the hook located on the tripod base as shown in Figure 2-10, and engage the notch in the lower corner of the -LM bracket with the enclosure tab.

Remove the washers, nuts and U-bolt from the U-bolt bracket. Install the bracket as shown in Figure 2-10 (bottom) with the U-bolt capturing the tripod leg. Tighten the nuts on the U-bolt until the lock washers are compressed.

Route the 14 AWG wire from the grounding lug on the bottom side of the enclosure to the grounding lug on the base of the tripod (Figure 2-6). Strip 1/2" of insulation from each end of the wire. Insert wire ends into the grounding lugs and tighten.

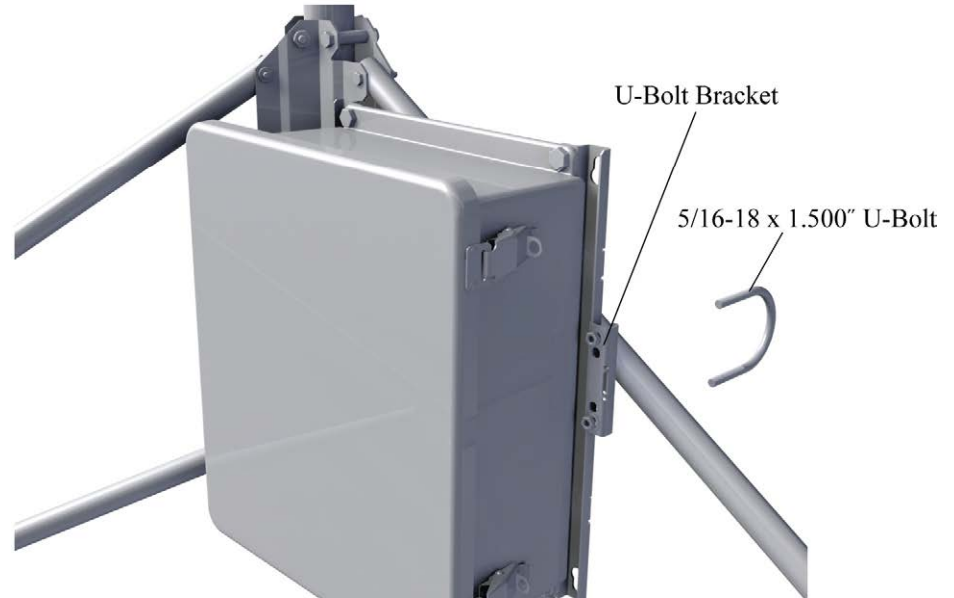

FIGURE 2-10. Enclosure with the -LM Bracket

### 3. General

The CM106K is a general purpose tripod that can be used for mounting sensors, solar panels, antennas, and instrument enclosures. The CM106K is constructed from galvanized steel, with individually adjustable legs that allow installation over uneven terrain. Height of the mast is 10 ft (3m).

The CM106K includes the tripod body, feet, brackets, grounding clamps, lightning rod, and mounting hardware. The remaining tripod components are user-supplied (see Section 2 for part specifications).

An optional guy kit is recommended for sites that experience high wind speeds (see Section 4, Allowable Wind Speed Specifications). Instrument enclosures can be purchased with mounting brackets that attach to either the mast or leg section as shown in Section 2.8.

The CM106K can be used for a variety of applications. For meteorological stations, sensors are mounted to the tripod using mounting brackets appropriate for the model of sensor. For non-meteorological applications the tripod can be used to mount instrument enclosures, solar panels, junction boxes, or antennas.

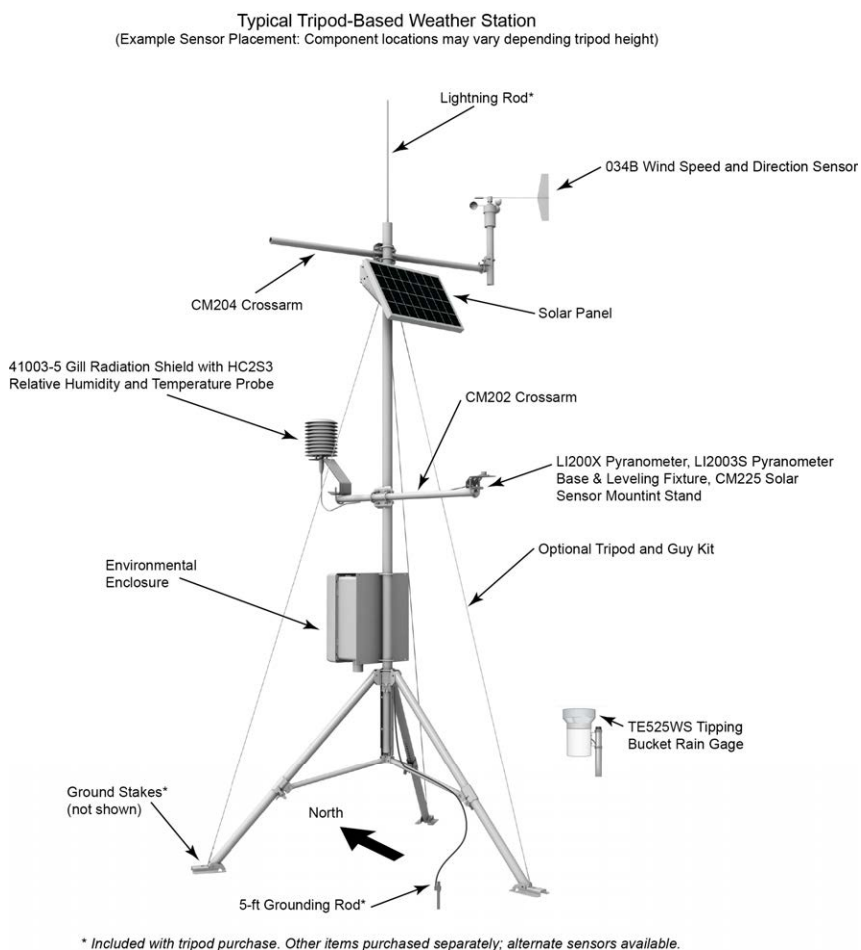

FIGURE 3-1. Typical tripod-based weather station

## 4. Specifications

|                             |  |
|-----------------------------|--|
| <b>Measurement Height:</b>  | 10 ft (3.0 m)  |
| <b>Vertical Load Limit:</b> | 100 lb (45 kg)   |
| <b>Mast Outer Diameter:</b> | 1.90 in. (48 mm)   |
| <b>Base Diameter:</b>       | 11 ft (3.4 m)  |
| <b>Leveling Adjustment:</b> | Clamp brackets on each leg, adjust individually  |
| <b>Leg Base:</b>            | 6 in. by 3.5 in. with one 0.84 in. hole for stakes<br>(150 x 89 mm with one 21 mm hole for stakes) |
| <b>Portability:</b>         | Collapsible to 9 in. diameter by 100 in (230 mm x 2.54 m) length                                   |
| <b>Weight with Mast:</b>    | 67 lb (30 kg)  |

### Allowable Wind Speeds\*

| Tripod Configuration | Sustained Wind   | Wind Gust        |
|----------------------|------------------|------------------|
| Unguyed              | 80 mph (36 m/s)  | 104 mph (46 m/s) |
| Guyed                | 115 mph (51 m/s) | 150 mph (67 m/s) |

\*Allowable wind speed values assume:

- Mast and leg components are made of steel (minimum yield strength of 36 ksi[248 MPa])and fabricated according to the specified design
- 14 x 16 in. enclosure at mast base
- 10.5 x 16.5 in. solar panel at mast base
- Crossarm and sensors (1.4 ft<sup>2</sup> projected area) at mast top
- Adequate ground anchors (stakes can pull out at lower wind speeds)

## 5. Tools List (for tripod, mast, enclosures, and crossarms)

1/2" and 7/16" open end wrenches  
 adjustable wrench  
 Phillips head screw drivers (medium, small)  
 Straight bit screwdrivers (large, medium)  
 12" torpedo level  
 side-cut pliers  
 pencil  
 tape measure  
 compass and site declination angle  
 shovel  
 sledge hammer (for driving ground rod and stakes)  
 step ladder



## 6. Tripod Components

The tripod body is packaged with the lightning rod. The optional guy kit is packaged separately.

## 7. Mounting Brackets

Mounting brackets covered in this section have U-bolts that attach to vertical and/or horizontal pipes with the following ranges of outside diameters:

|                                | inches    | mm          | Nominal Pipe Size (inches) |
|--------------------------------|-----------|-------------|----------------------------|
| 1.5" U-bolt                    | 1.0 – 1.5 | 25.4 – 38.1 | ¾ – 1                      |
| 2" U-bolt                      | 1.3 – 2.1 | 33.0 – 53.3 | 1 – 1 ½                    |
| 2" U-bolt with plastic V-block | 1.0 – 2.1 | 25.4 – 53.3 | ¾ – 1 ½                    |

Some of the brackets (e.g. the CM210) include 1.5" and 2" U-bolts to extend the range of pipe diameters that the bracket can accommodate. Brackets with holes for a 1.5" U-bolt will accept a user-supplied 1.75" U-bolt.

### 7.1 CM210 Crossarm Mounting Kit

CM200 series crossarms include a CM210 bracket as shown in Figure 7-1. The CM210 can be ordered separately to attach a user-supplied pipe (1.0 – 1.5" OD) to a mast or tower leg (1.0 – 2.1" OD), or to attach a crossarm to two tower legs.

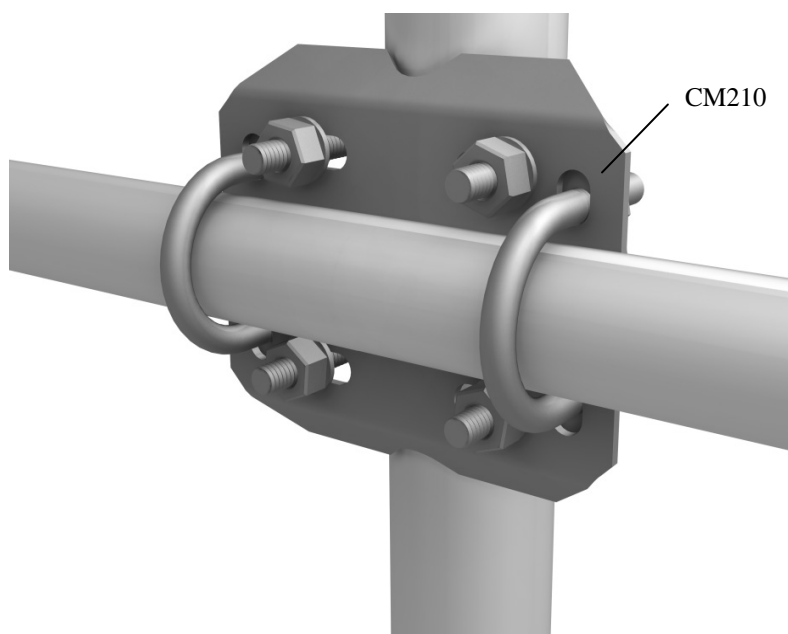

FIGURE 7-1. CM210 Crossarm Mounting Kit (shown with user-supplied pipe)

## 7.2 CM216 Mast Mounting Kit

The CM216 attaches to the top of the mast, and provides a 3/4" or 1" mounting pipe (1.05" or 1.32" OD) that extends 4" above the mast, as shown in Figure 7-2.



FIGURE 7-2. CM216 Mast Mounting Kit

### 7.3 CM220 Right Angle Mounting Kit

The CM220 attaches a vertical pipe (1.0 – 1.5" OD) to the CM200 series crossarms or horizontal pipe (1.0 – 1.5" OD) as shown in Figure 7-3.



FIGURE 7-3. CM220 Right Angle Mounting Kit

## 7.4 CM225 and 18098 Pyranometer Mounting Stand

The CM225 is used to attach a pyranometer or quantum sensor to a horizontal pipe (1.0 to 2.1" OD) or vertical pole (1.0 to 2.1" OD).

The LI200X pyranometer and LI190SB quantum sensor mount to the CM225 via the LI200S leveling base (see Figure 7-4). The CS300 pyranometer mounts to the CM225 via the 18356 leveling base. The CMP3 and LP02 pyranometers include their own bubble level and leveling screws allowing them to mount directly to the CM225.

The 18098 provides a larger surface for mounting a user-supplied Eppley pyranometer.

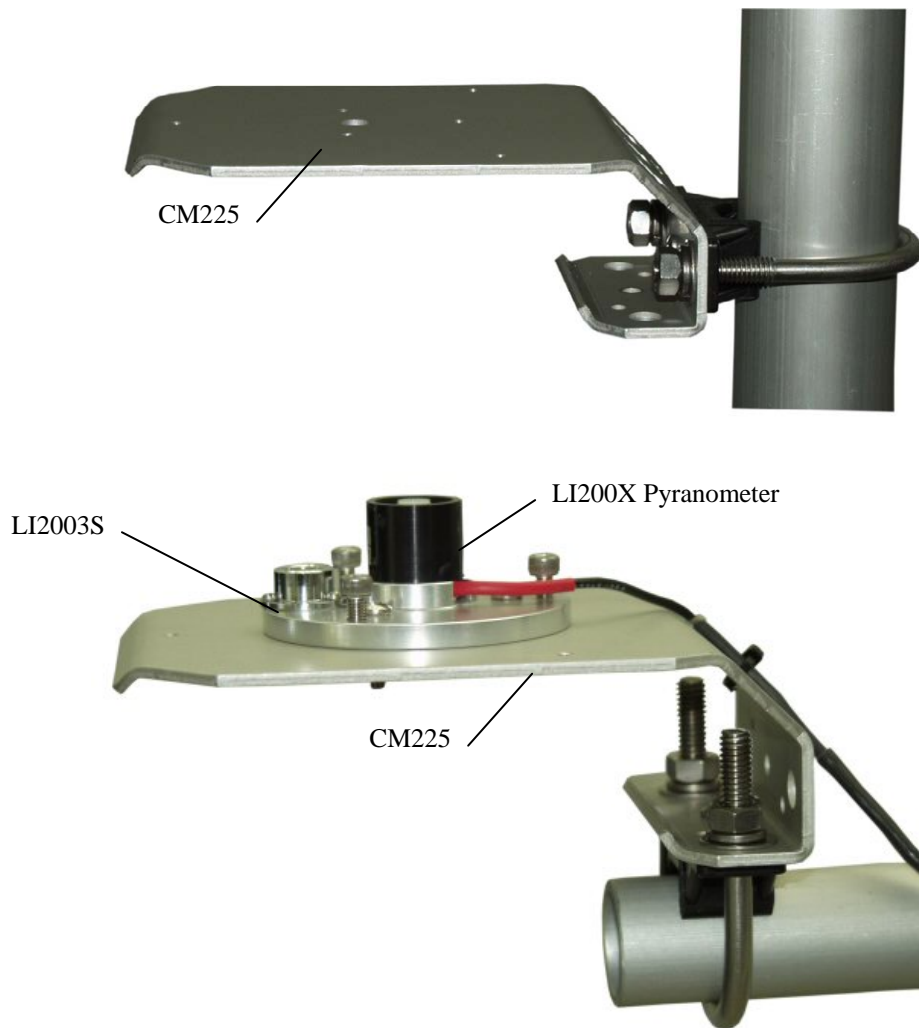

FIGURE 7-4. CM225 Pyranometer Mounting Stand

## 7.5 CM230 Adjustable Angle Mounting Kit

The CM230 mounts an antenna (1.0 – 1.5" OD) to a mast or vertical pipe (1.3 – 2.1" OD) as shown in Figure 7-5. The bracket allows the antenna to be adjusted for different angles.

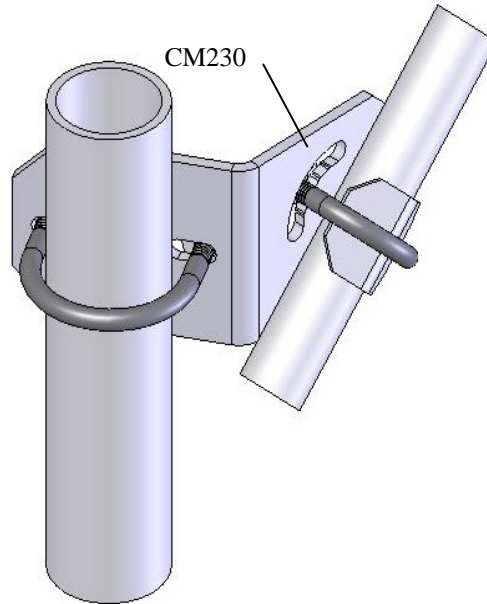

FIGURE 7-5. CM230 Adjustable Angle Mounting Kit

## 7.6 CM235 Magnetic Mounting Stand

The CM235 provides a 3.5" (8.8 cm) square platform for mounting magnetic base antennas. The CM235 attaches to horizontal or vertical pipes (1.0 – 2.1" OD) as shown in Figure 7-6.



FIGURE 7-6. CM235 Magnetic Mounting Stand

## 7.7 RM Young Gill Radiation Shields

RM Young Gill Radiation Shields are used to house and attach temperature and relative humidity sensors to the tripod mast (1.0 – 2.1” OD) or crossarm as shown in Figure 7-7. Radiation shields ship with the U-bolt configured for attachment to a vertical pipe. To attach the radiation shield to a horizontal pipe, the U-bolt and plastic V-block must be moved to the other set of holes.



FIGURE 7-7. RM Young Gill Radiation Shield







## **Campbell Scientific Companies**

---

### **Campbell Scientific, Inc. (CSI)**

815 West 1800 North  
Logan, Utah 84321  
UNITED STATES  
www.campbellsci.com • info@campbellsci.com

### **Campbell Scientific Africa Pty. Ltd. (CSAf)**

PO Box 2450  
Somerset West 7129  
SOUTH AFRICA  
www.csafrica.co.za • cleroux@csafrica.co.za

### **Campbell Scientific Australia Pty. Ltd. (CSA)**

PO Box 8108  
Garbutt Post Shop QLD 4814  
AUSTRALIA  
www.campbellsci.com.au • info@campbellsci.com.au

### **Campbell Scientific do Brazil Ltda. (CSB)**

Rua Luisa Crapsi Orsi, 15 Butantã  
CEP: 005543-000 São Paulo SP BRAZIL  
www.campbellsci.com.br • suporte@campbellsci.com.br

### **Campbell Scientific Canada Corp. (CSC)**

11564 - 149th Street NW  
Edmonton, Alberta T5M 1W7  
CANADA  
www.campbellsci.ca • dataloggers@campbellsci.ca

### **Campbell Scientific Centro Caribe S.A. (CSCC)**

300 N Cementerio, Edificio Breller  
Santo Domingo, Heredia 40305  
COSTA RICA  
www.campbellsci.cc • info@campbellsci.cc

### **Campbell Scientific Ltd. (CSL)**

Campbell Park  
80 Hathern Road  
Shepshed, Loughborough LE12 9GX  
UNITED KINGDOM  
www.campbellsci.co.uk • sales@campbellsci.co.uk

### **Campbell Scientific Ltd. (France)**

3 Avenue de la Division Leclerc  
92160 ANTONY  
FRANCE  
www.campbellsci.fr • info@campbellsci.fr

### **Campbell Scientific Spain, S. L.**

Avda. Pompeu Fabra 7-9, local 1  
08024 Barcelona  
SPAIN  
www.campbellsci.es • info@campbellsci.es

*Please visit [www.campbellsci.com](http://www.campbellsci.com) to obtain contact information for your local US or International representative.*