

APPLICATION NOTE

Measuring Current Output Transducers with Campbell Scientific Dataloggers



CAMPBELL SCIENTIFIC, INC.

815 W. 1800 N. • Logan, Utah 84321-1784 • (435) 753-2342 • FAX (435) 750-9540

Measuring Current Output Transducers with Campbell Scientific Dataloggers

This application note describes using Campbell Scientific dataloggers to measure transducers that output current signals.

Because our dataloggers measure voltages, the current signal must be converted to a voltage before the datalogger can measure the transducer. Ohm's Law, which states $V=(I)(R)$, allows the signal current (I) to be measured as a voltage (V) by using a completion resistor (R). Typically, Campbell Scientific's CURS100 should be used for the completion resistor.

Measurement Concepts

Transducers that output current signals consist of a:

- **Current loop sensor** — produces a signal that changes in a known way with the phenomenon being measured.
- **Current transducer** — converts the sensor signal into a linear current signal.
- **Power supply** — provides power to the sensor and transducer.

Current loop transducers that are measured with our dataloggers also require a completion resistor, typically the CURS100. The datalogger measures the voltage dropped across the completion resistor.

Differential Measurements

Before you measure the transducer differentially, place the completion resistor between the high and low terminal and tie the low terminal to ground (G for the CR510, CR10(X), and CR23X and \perp for the 21X, CR5000, CR7, and CR9000(C)).

Differential measurements measure the voltage between two inputs; both inputs must be within the datalogger's common mode range. The common mode range is ± 2.5 volts for the CR510 and CR10(X) and ± 5 volts for the 21X, CR23X, CR5000, CR7, and CR9000(C).

Single-Ended Measurements

Single-ended measurements are made on a single-ended input channel with respect to ground (AG for the CR510 and CR10(X) and \perp for the 21X, CR23X, CR5000, CR7, and CR9000(C)).

When current flows through the ground path on the datalogger, the actual voltage at the different ground terminals is slightly different. The small offset voltages between the ground points are caused because there is resistance (albeit small) in the ground path and current flowing through a resistance results in a voltage drop. The offsets in ground voltage cause offsets in single-ended voltage measurements.

CR510, CR10(X), CR23X, and CR5000

The CR510, CR10(X), CR23X, and CR5000 have two types of ground terminals (AG and G terminals for the CR510 and CR10(X); \perp and G for the CR23X and CR5000). The G terminals are used for power and shield connections where there is likely to be current flowing. These terminals are connected directly to earth ground (a grounding rod) to provide a path to earth for transient voltages. By avoiding the use of AG or \perp as a current path, the terminals stay at the same ground potential and do not cause offsets in single-ended measurements.

All ground connections to the CR510, CR10(X), CR23X, and CR5000 should be made at a G terminal.



When using the CURS100, do NOT use its ground terminal.

21X, CR7, CR9000(C)

The 21X, CR7, and CR9000(C) dataloggers have only one type of ground terminal. The 21X may have a slightly higher ground path resistance than the CR7 or CR9000(C). When current is allowed to flow in the ground path, the offset voltages on single-ended measurements can be as high as several millivolts. The more current signals measured, the larger this offset voltage can become. To reduce the amount of current flowing in the 21X ground path, it is recommended that a separate power supply be used to power current transducers.

Choosing the Completion Resistor



If you're using a 4 to 20 mA transducer, we suggest you use our CURS100.

Proper resistor selection is important because the quality of the completion resistor directly affects the quality of the measurement. Each resistor has a resistor tolerance and temperature sensitivity rating.

Resistor Tolerance

Resistor tolerance describes the deviation a resistor can have from its labeled value.

Typically, a precision resistor is used because inexpensive resistors can have a resistor tolerance of 5% or higher. Precision resistors are available with resistor tolerances of 0.1% and 0.01%. The price of a 0.01% tolerance resistor may be several times the price of a 0.1% tolerance resistor.

Resistor tolerance error can be eliminated by measuring the resistance with a precision ohm meter. Use the measured value of the resistance to compute the signal voltage created by the transducer's current. Purchasing 0.01% resistors may eliminate the need to check each resistor's value. This also makes the resistors interchangeable.



Consider the accuracy of the transducer before choosing a resistor. You do not benefit from using an expensive and difficult to find precision resistor if the transducer is the limiting factor in measurement accuracy.

Temperature Sensitivity

The resistor's temperature sensitivity rating is listed as "Tn" where the n is the number of parts per million the resistor will vary due to a change in a degree Celsius (e.g., a T10 resistor varies 10 parts per million per degree Celsius temperature change).

Common resistor temperature sensitivity is T100 or more. Choose T2, T5, or T10 resistors when it's important to minimize error due to temperature variation.

Calculating the Maximum Resistor Size

Calculating the maximum resistor size can help you select a compatible completion resistor. If you're using a 4 to 20 mA transducer, we suggest you use our CURS100 and therefore will not need to calculate the maximum resistor size.

To calculate the maximum resistor size, use Ohm's Law and solve for resistance:

$$R = V/I$$

Where,

R—resistance in ohms

V—the selected datalogger full scale range in volts (see the datalogger's Full Scale Range section).

I—current output from the transducer in amps

Example:

For a transducer that has a maximum current output of 25 mA, use the 5 V range for the datalogger's full scale range when using a 21X, CR23X, CR5000, CR7, or CR9000(C). The maximum resistor size for this transducer using one of these dataloggers is:

$$\begin{aligned} R &= 5.0 \text{ V} / 0.025 \text{ A} \\ &= 200 \text{ } \Omega \end{aligned}$$

For the CR510 or CR10(X), use the 2.5 V range for the datalogger's full scale range. The maximum resistor size is:

$$\begin{aligned} R &= 2.5 \text{ V} / 0.025 \text{ A} \\ R &= 100 \text{ } \Omega \end{aligned}$$

You must also consider the resistor tolerance.

Example:

A 200 Ω resistor with a resistor tolerance of 5% can produce a resistance as high as:

$$(200 \Omega)(0.05) + 200 \Omega = 210 \Omega$$

Therefore, a 200 W resistor with a 5% resistor tolerance may not work for the 21X, CR23X, CR7, CR5000, and CR9000(C) example.

Campbell Scientific Completion Resistors

The following are available from Campbell Scientific:

<u>CSI Part no.</u>	<u>Tolerance</u>	<u>T value</u>	<u>Resistance</u>
CURS100	±0.01%	T4 (0° to 60°) T8 (-55° to 125°C)	100 Ω
3080	±0.1%	T10	125 Ω
7674	±0.01%	T5	125 Ω

Transducers that produce signals from 4 to 20 mA should use the CURS100.



A 250 ohm resistor can be made by using two 125 ohm resistors in series.

Consider Minimum Transducer Supply Voltage

When a current transducer is powered by the same 12 volt supply as the datalogger, the voltage drop across the resistor must be small enough that sufficient voltage remains to power the transducer.

Follow these steps to determine whether you'll have sufficient voltage to power the transducer:

1. Use Ohms Law to calculate the voltage drop across the resistor.
2. Subtract the voltage drop from the datalogger's power supply voltage to determine the amount of voltage left to power the transducer (Kirchoff's Voltage Law).

3. Compare that voltage with the minimum supply voltage of the transducer. If there is not enough voltage to power the transducer, either use a smaller resistor or a separate power supply to power the transducer.

Example:

A transducer that produces a 20 mA (0.02 A) signal requires a minimum supply voltage of 10 V. If a 250 Ω resistor is used to complete the current loop, using Ohms law, the voltage drop across the resistor will be:

$$V = (0.02 \text{ A})(250 \text{ } \Omega)$$

$$= 5 \text{ V}$$

The voltage that remains to power the transducer will be (see Figure 1):

$$12 \text{ V} - 5 \text{ V} = 7 \text{ V}$$

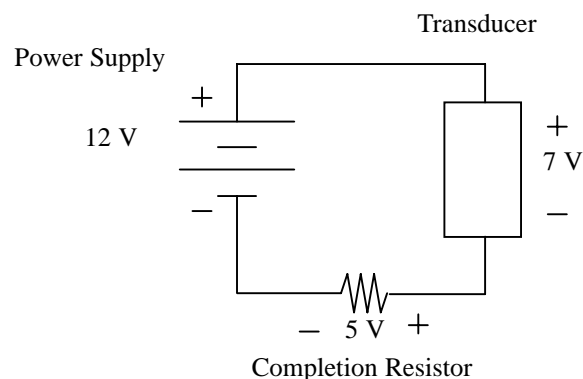

FIGURE 1. Example of a transducer with a 20 mA signal

Because the transducer requires 10 V, a smaller resistor must be used or a separate power supply must power the transducer.

If we use a 25 Ω resistor instead, the voltage drop across the resistor will be:

$$V = (0.02 \text{ A})(25 \text{ } \Omega)$$

$$= 0.5 \text{ V}$$

The voltage that remains to power the transducer will be:

$$12 \text{ V} - 0.5 \text{ V} = 11.5 \text{ V}$$

Since the transducer requires 10 V, sufficient voltage will remain to power the transducer.

Types of Current Loop Transducers

Two-Wire Current Loop Transducers

The resistor must be grounded at the datalogger to ensure that the measurement is within common mode range. The signal (or low) output on the transducer is higher than the datalogger ground by the voltage drop across the resistor. A ground-loop error may occur if the signal output is not electrically isolated but is connected to the sensor's case. If such a sensor is in contact with earth ground (i.e., a pressure transducer in a well or stream), an alternative path for current flow is established through earth ground to the datalogger earth ground. This path is in parallel with the path from the signal output through the resistor; hence not all the current will pass through the resistor and the measured voltage will be too low. Figures 2 through 4 are wiring diagrams for two-wire current loop transducers.

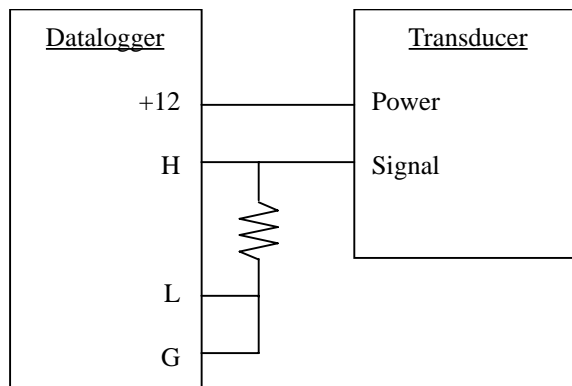

FIGURE 2. Differential measurement with the two-wire transducer powered by the datalogger

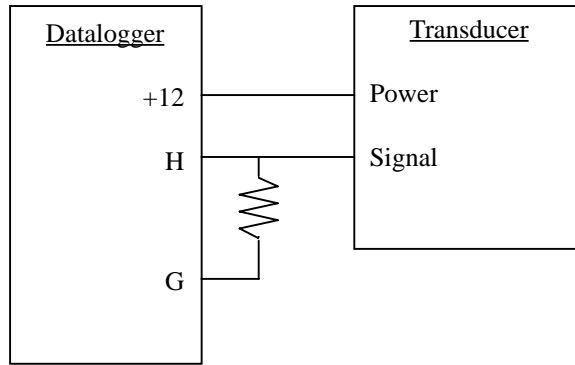

FIGURE 3. Single-ended measurement with the two-wire transducer powered by the datalogger

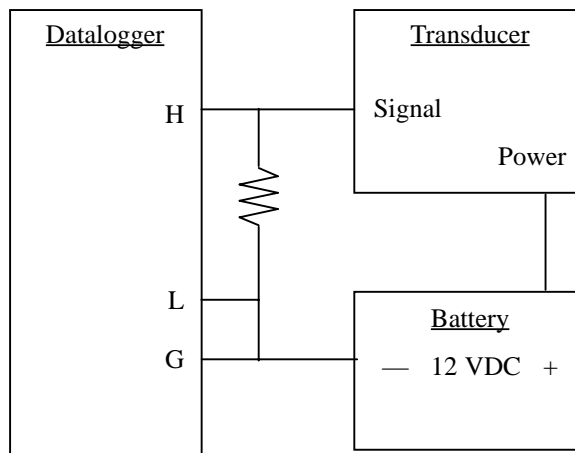

FIGURE 4. Differential measurement with the two-wire transducer powered externally

Three-Wire Current Loop Transducers

The major attribute of a three-wire current loop transducer is that you can tie the sensor's ground to the datalogger's ground. This eliminates ground loops. Figures 5 through 7 are wiring diagrams for three-wire transducers.

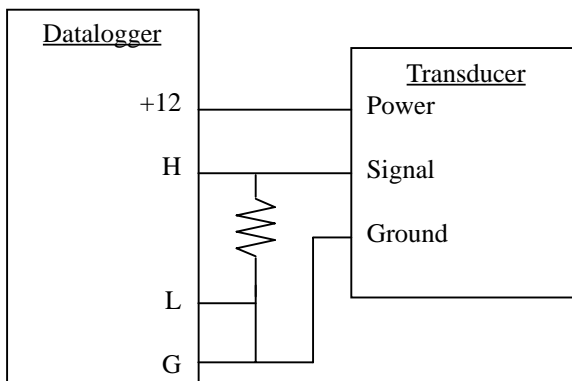

FIGURE 5. Differential measurement with a three-wire transducer powered by the datalogger

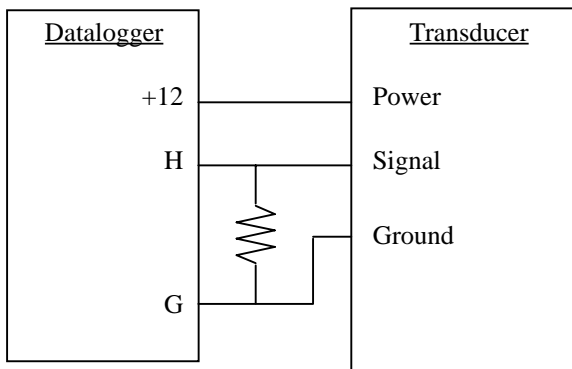

FIGURE 6. Single-ended measurement with a three-wire transducer powered by the datalogger

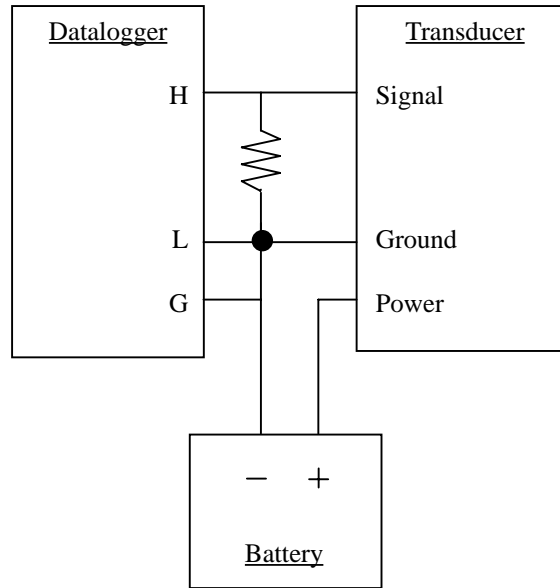

FIGURE 7. Differential measurement with the three-wire transducer powered externally

Four-Wire Current Loop Transducers

The signal ground of four-wire current loop transducers may or may not be internally tied to the power ground. If the signal ground is not internally tied, the transducer's ground lead will need to be attached to the datalogger's ground. Figures 8 through 10 are wiring diagrams for four-wire transducers.

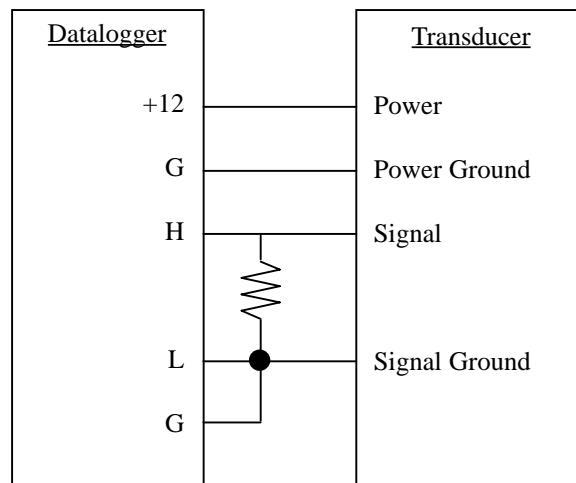

FIGURE 8. Differential measurement with the four-wire transducer powered by the datalogger

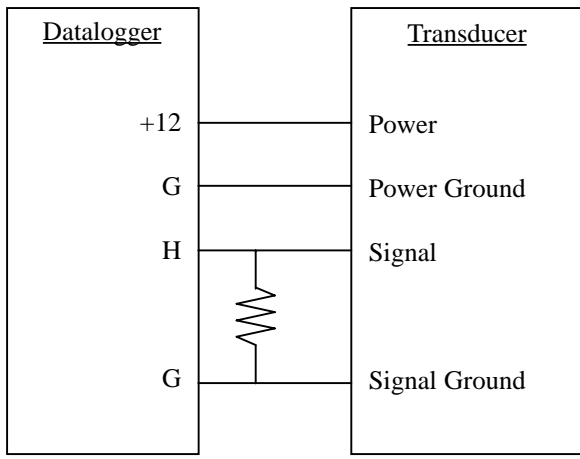

FIGURE 9. Single-ended measurement with the four-wire transducer powered by the datalogger

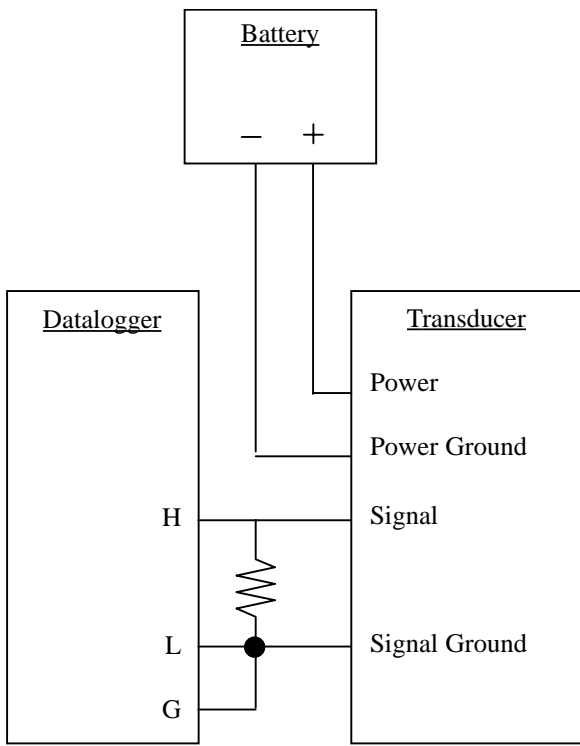

FIGURE 10. Differential measurement with the four-wire transducer powered externally

Programming

The datalogger is programmed using EDLOG or a Keyboard/Display. Use Instruction 2--Differential Voltage or Instruction 1--Single-Ended Voltage to measure the voltage across the resistor.



If possible, measure the voltage across the resistor as a differential measurement.

The Datalogger's Full Scale Voltage Range

The voltage range on which to make the measurement should be the smallest range that will accommodate the maximum signal the sensor will output. Using the smallest possible range will give the best resolution.

Example:

Calculate the datalogger's full scale range when using a 4 to 20 mA transducer with a CURS100 completion resistor. The CURS100 produces a 100 Ω resistance.

The maximum voltage occurs at the maximum current. Thus, a 4 to 20 mA transducer will output its maximum voltage at 20 mA.

Using Ohms Law, the maximum voltage is:

$$V = (R) (I)$$

$$V = (100 \Omega) (0.02 \text{ A}) = 2 \text{ V}$$

The smallest possible range that can measure an output of 2 volts is the ± 2500 mV range on the CR510 or CR10(X) or the ± 5000 mV range on the 21X, CR23X, CR5000, CR7, or CR9000(C).

Calculating the Multiplier and Offset

To calculate the multiplier, use the equation for a line and calculate the slope:

$$(y - y_1) = m (x - x_1)$$

or

$$m = (y - y_1) / (x - x_1)$$

For the offset, calculate the y-intercept of a line:

$$y = m(x) + b$$

or

$$b = y - m(x)$$

Where:

m— the multiplier

y— the transducer's upper limit of its full scale range

y₁— the transducer's lower limit of its full scale range

x— the voltage across the resistor at y (use Ohms law to calculate the voltage)

x₁— the voltage across the resistor at y₁ (use Ohms law to calculate the voltage)

b— the offset

Example:

A current loop transducer is used to detect pressure. The full scale range of the transducer is 200 to 700 psi.

The transducer outputs 4 mA (0.004 A) at 200 psi and 20 mA (0.02 A) at 700 psi.

Using the CURS100, the resistance is 100 Ω.

Using Ohm's Law, the voltage across the resistor at 200 psi is:

$$\begin{aligned} x_1 &= (0.004 \text{ A})(100 \text{ } \Omega) \\ &= 0.4000 \text{ V or } 400 \text{ mV} \end{aligned}$$

and at 700 psi is:

$$\begin{aligned} x &= (0.020 \text{ A})(100 \text{ } \Omega) \\ &= 2.0000 \text{ V or } 2000 \text{ mV} \end{aligned}$$

Since the datalogger measures in mV, the multiplier (or slope) must be in units of psi/mV. Therefore, the y values units are psi and the x values units are mV. Using the equation for a line, the multiplier is:

$$\begin{aligned}
 m &= \frac{y - y_1}{x - x_1} \\
 &= \frac{700 \text{ psi} - 200 \text{ psi}}{2000 \text{ mV} - 400 \text{ mV}} \\
 &= .3125 \text{ psi/mV}
 \end{aligned}$$

Calculate the y-intercept of a line to calculate the offset:

$$\begin{aligned}
 b &= y - m(x) \\
 &= 700 \text{ psi} - (0.3125 \text{ psi/mV})(2000 \text{ mV}) \\
 &= 75.00 \text{ psi}
 \end{aligned}$$

CR10(X) Program Example

```

1: Volt (Diff) (P2)
  1:      1      Reps
  2:     25     2500 mV 60 Hz Rejection Range
  3:      1     DIFF Channel
  4:      1     Loc [ Press_psi ]
  5:     0.3125 Mult
  6:     75     Offset
    
```

CR23X Program Example

```

1: Volt (Diff) (P2)
  1:      1      Reps
  2:     25     5000 mV, 60 Hz Reject, Fast Range
  3:      1     DIFF Channel
  4:      1     Loc [ Press_psi ]
  5:     0.3125 Mult
  6:     75     Offset
    
```

21X Program Example

```

1: Volt (Diff) (P2)
  1: 1      Reps
  2: 5      5000 mV Slow Range
  3: 1      DIFF Channel
  4: 1      Loc [ Press_psi ]
  5: 0.3125 Mult
  6: 75     Offset
    
```

CR7 Program Example

```

1: Volt (Diff) (P2)
  1: 1      Reps
  2: 8      5000 mV Slow Range
  3: 1      In Card
  4: 1      DIFF Channel
  5: 1      Loc [ Press_psi ]
  6: 0.3125 Mult
  7: 75     Offset
    
```

CR9000 Program Example

```
VoltDiff(Press_psi, 1, mV 5000, 5, 1, 1, 0, 0, 0.3125, 75)
```

Advantages and Disadvantages of Current Loop Transducers

Advantages:

- The current signal remains constant over long leads
- For 4 to 20 mA devices, a 4 mA signal indicates a zero measurement, providing a differentiation between a zero measurement and a non-functioning transducer

Disadvantages:

- Most require constant current from the power supply increasing the cost and size of the system
- The conditioned output quality may not be as good as a similar unconditioned sensor measured directly by the datalogger
- All inputs must be referenced to datalogger ground. If different sensors have different power supplies/ground references, the ground connection on the datalogger will tie these together, possibly causing “ground loop” measurement errors.

